

INSTALLATION GUIDE



NOTE:

Refer to construction drawings
for project specific details.
Construction drawings
have precedence over these
installation guidelines.

Safety Notes:

Cold formed steel components may have sharp edges after fabrication. Appropriate PPE should be worn to avoid injury.

Load ratings are project specific - please contact Unirac or refer to U-Builder.

Any loose components or fasteners shall be re-tightened in accordance with these instructions.

Any components showing signs of damage that compromise safety shall be replaced immediately.

Safety Note: Cold formed steel components may have sharp edges after fabrication. Appropriate PPE should be worn to avoid injury.

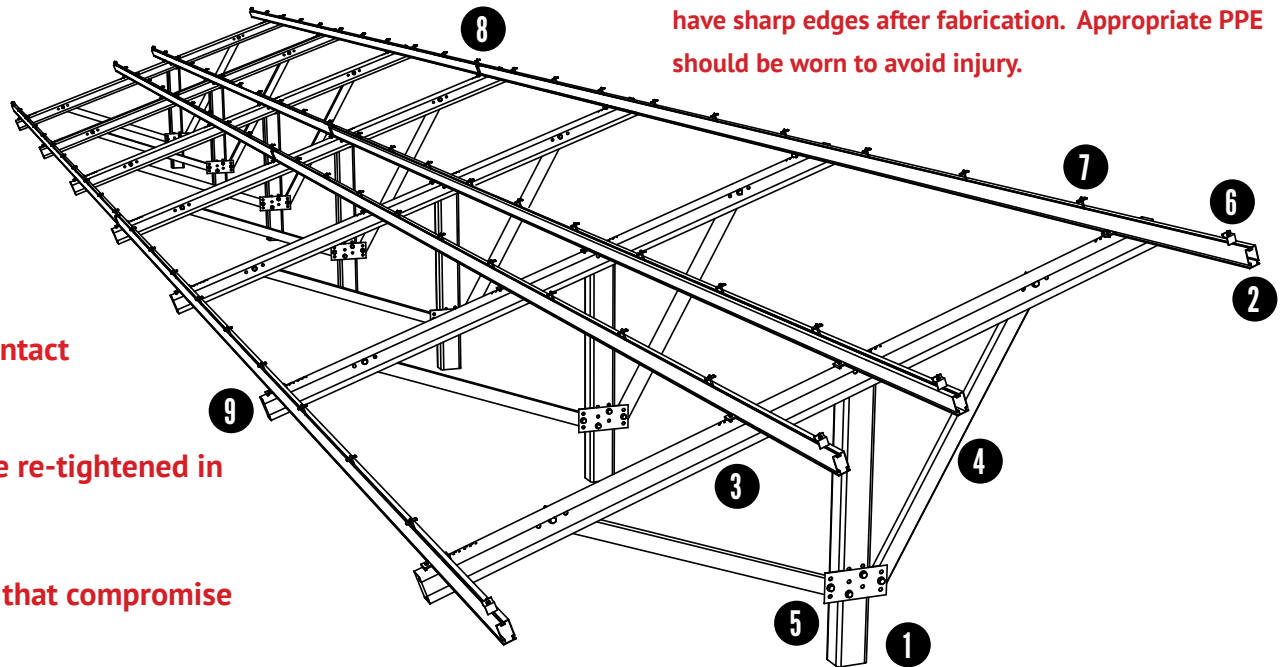

ITEM	COMPONENT	MATERIAL
1	Roll- Formed Steel Pile	4" or 4.5 " x 6" C Shape (Length Varies by Project)
2	Aluminum East-West Beam	Aluminum Beam with Continuous Slots for Adjustability
3	Roll-Formed Steel Top Chord	C Shape with Custom Hole Pattern for Adjustability
4	Roll-Formed Steel Diagonal Brace	C Shape
5	Steel Diagonal Brace Plate	Steel Plate with Custom Hole Pattern for Adjustability
6	End Clamp	End Clamp Assembly with T-Bolt
7	Mid Clamp	Mid Clamp Assembly with T-Bolt
8	Nested Splice Member	Internal Aluminum Splice Retained with Self-Tapping Screws
9	East-West Beam Clamp	Aluminum Extruded Clamp with Stainless Steel Hardware

TORQUE REQUIREMENTS FOR THE GFT PRODUCT:

1/4"Ø HARDWARE = 9 - 11 FT-LBS
 5/8"Ø HARDWARE = 54 - 66 FT-LBS
 3/4"Ø HARDWARE = 99 - 121 FT-LBS

**Note: Ensure Torque wrenches have been calibrated.
 See appendix for different clamp configurations**

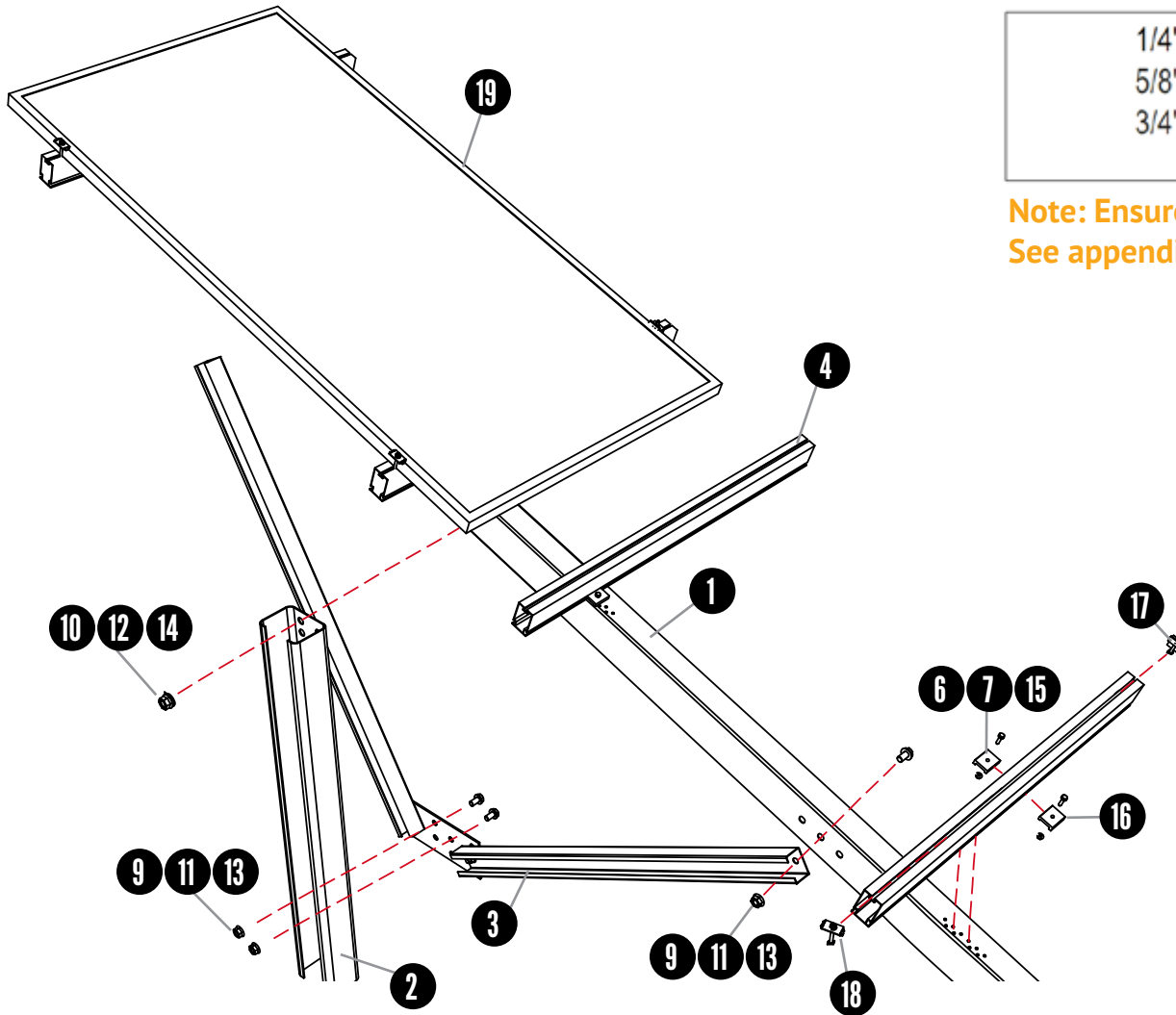

ITEM	COMPONENT
1	4.1" Top Chord Channel
2	6" x 4" or 4.5" C-Shape Pile
3	Diagonal Brace Assembly
4	3.25" x 2" East-West Aluminum Beam
5	Rail Splice - See page 6
6	Flat Washer 1/4"
7	Hex Flange Nut 1/4-20 Serrated
8	Rail splice connection - See page 6
9	Flat Washer 5/8"
10	Flat Washer 3/4"
11	Hex Bolt 5/8-11" x 1-1/2"
12	Hex Bolt 3/4-10" x 1-1/2"
13	Hex Flange Nut 5/8-11 Serrated
14	Hex Flange Nut 3/4-10 Serrated
15	Hex Bolt 1/4-20 x 1"
16	East-West Rail Clip
17	Standard End Clamp Assembly
18	Standard Mid Clamp Assembly
19	PV Module (By Others)

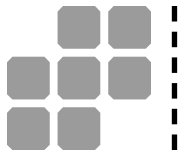

Standard Mid Clamp Assembly with T-Bolt

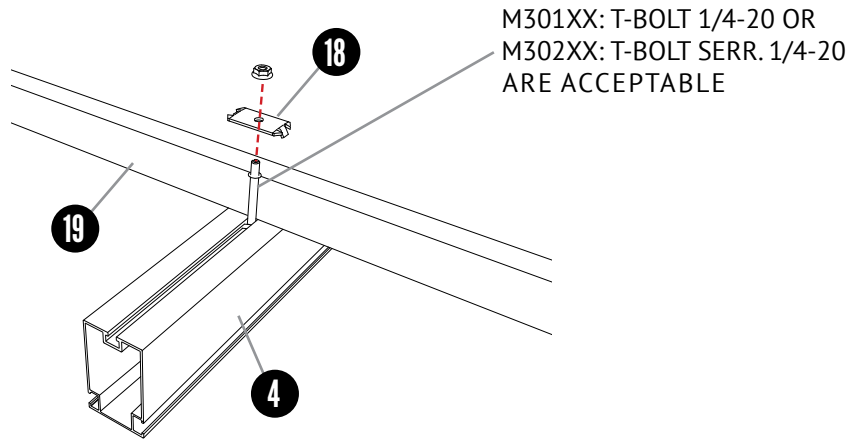

Standard End Clamp Assembly with T-Bolt

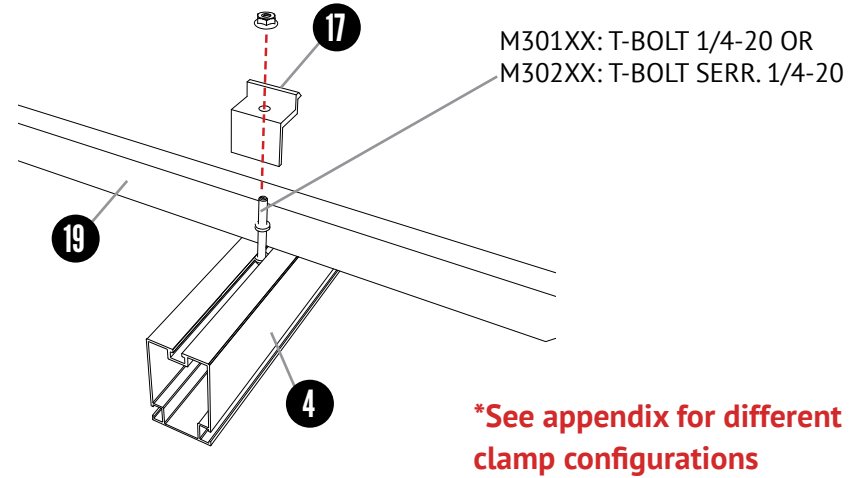

Mid Clamp Assembly With T-Bolt

ITEM	COMPONENT	MATERIAL
4	3.25" x 2" East-West Aluminum Beam	Aluminum Alloy 6005A-T61, 6351-T5 or 6061-T6
18	Mid Clamp	Stainless Steel, 301,302, or 304, 1/4 Hard, Mill Finish
19	PV Module (By Others)	As per Manufacturer
SEE DWG	1/4-20 T-Bolt (Serrated or Non-Serrated)	300 Stainless Steel (301 Preferred)
SEE DWG	1/4-20 Serrated Flange Nut	Stainless Steel ASTM F594

End Clamp Assembly With T-Bolt

ITEM	COMPONENT	MATERIAL
4	3.25" x 2" East-West Aluminum Beam	Aluminum Alloy 6005A-T61, 6351-T5 or 6061-T6
17	End Clamp	Stainless Steel, 301,302, or 304, 1/4 Hard, Mill Finish
19	PV Module (By Others)	As per Manufacturer
SEE DWG	1/4-20 T-Bolt (Serrated or Non-Serrated)	300 Stainless Steel (301 Preferred)
SEE DWG	1/4-20 Serrated Flange Nut	Stainless Steel ASTM F594

East-West Rail Clip

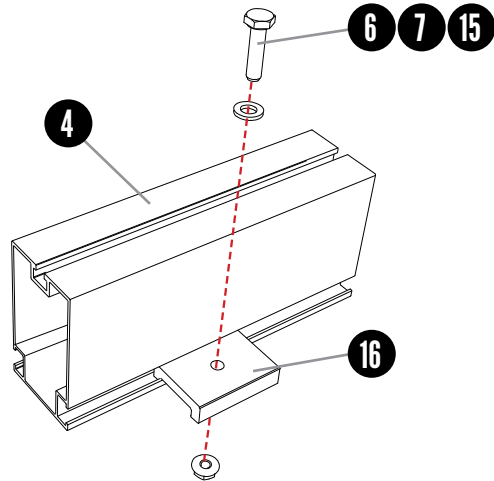

East-West Beam Splice

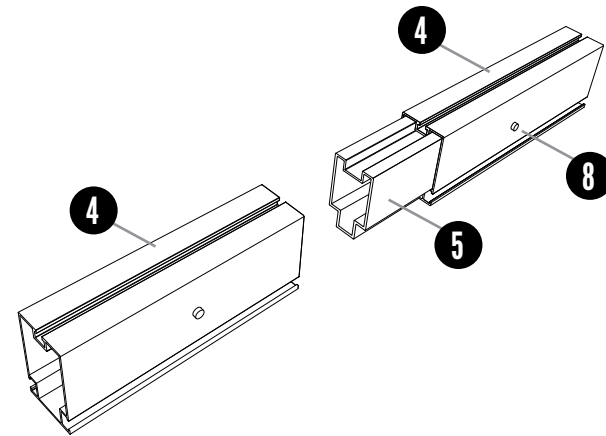

East-West Rail Clip

ITEM	COMPONENT	MATERIAL
4	3.25" x 2" East-West Aluminum Beam	Aluminum Alloy 6005A-T61, 6351-T5 or 6061-T6
6	Flat Washer 1/4"	Stainless Steel ASTM F594
7	Hex Flange Nut 1/4-20 Serrated	302HQ 18/8 Stainless Steel Austenitic 300 Series
15	Hex Bolt 1/4-20 x 1"	302HQ 18/8 Stainless Steel Austenitic 300 Series
16	East-West Rail Clip	Aluminum Alloy 6005A-T61, 6351-T5 or 6061-T6

East-West Beam Splice

ITEM	COMPONENT	MATERIAL
4	3.25" x 2" East-West Aluminum Beam	Aluminum Alloy 6005A-T61, 6351-T5 or 6061-T6
5	East-West Beam Splice Insert	Aluminum Alloy 6005A-T61, 6351-T5 or 6061-T6
8	1/4" x 20 Self Drilling Screw (Buildex)	ASTM A449/ SAE J429 (Similar Properties Confirmed by testing)

Top Chord to Pile Connection

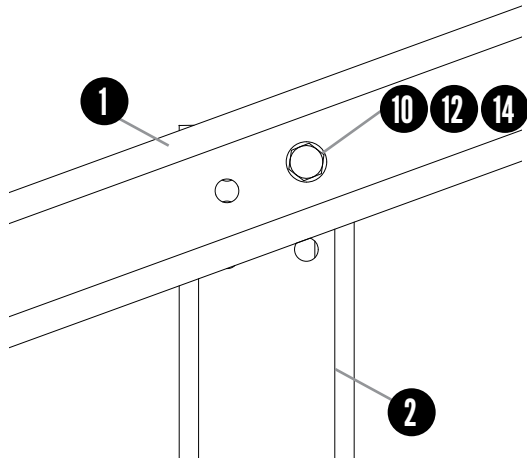

Diagonal Brace Plate to Pile Connection

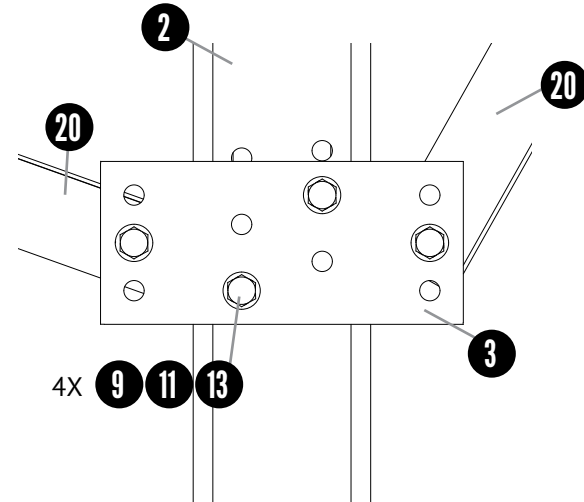

Top Chord to Pile Connection

ITEM	COMPONENT	MATERIAL
1	4.1" Top Chord Channel	Cold Rolled ASTM A653 HSLAS
2	6" x 4 or 4.5" C-Shape Pile	Cold Rolled ASTM A653 HSLAS
10	Flat Washer 3/4"	SAE Type A Narrow
12	Hex Bolt 3/4-10 x 1-1/2"	SAE J429
14	Hex Flange Nut 3/4-10 Serrated	SAE J429

Diagonal Brace Plate to Pile Connection

ITEM	COMPONENT	MATERIAL
2	6" x 4 or 4.5" C Shape Pile	Cold Rolled ASTM A653 HSLAS
3	Diagonal Brace Plate	ASTM A36 or ASTM A653
9	Flat Washer 5/8"	SAE Type A Narrow
11	Hex Bolt 5/8-11 x 1-1/2"	SAE J429
13	Hex Flange Nut 5/8-11 Serrated	SAE J429
20	Diagonal Brace	Cold Rolled ASTM A653 HSLAS

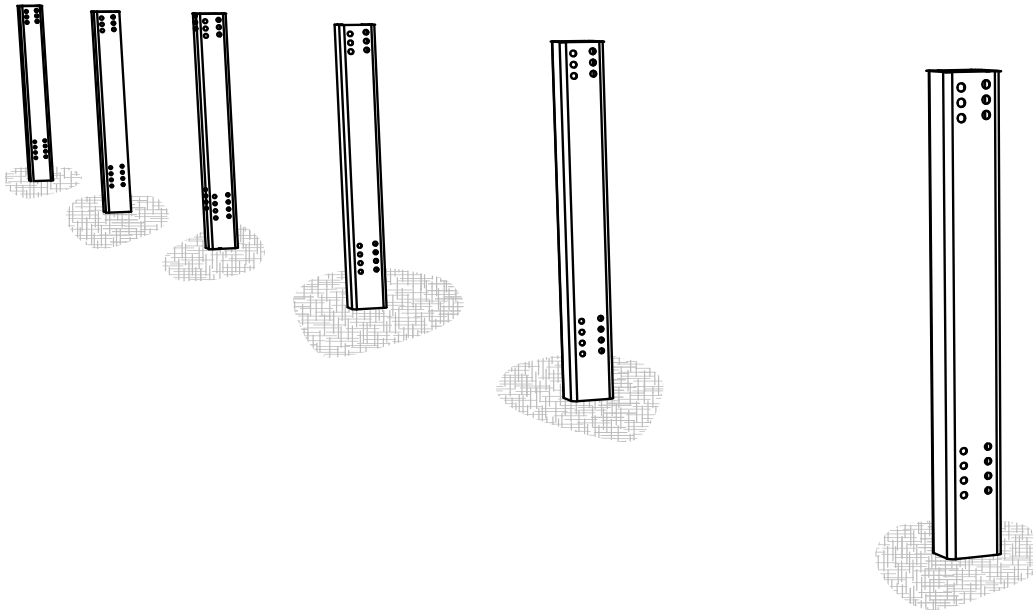

All piles within single table must be oriented to face the same direction per the construction drawings.

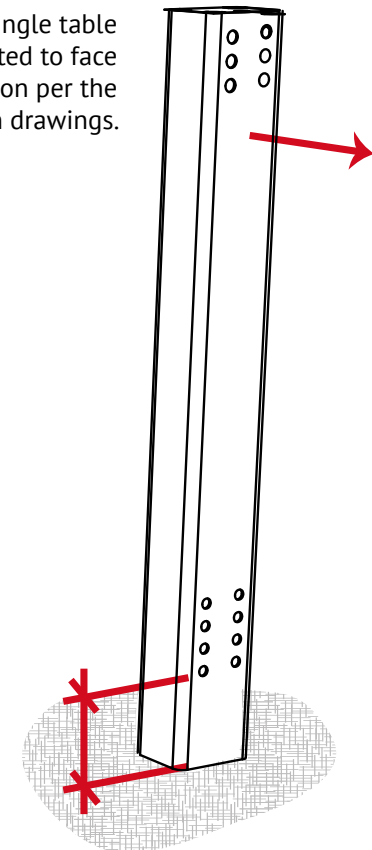

Hole height above grade per construction drawings.

Note:
C-Piles must be installed with C open to the West.

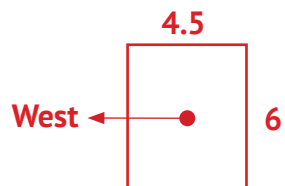

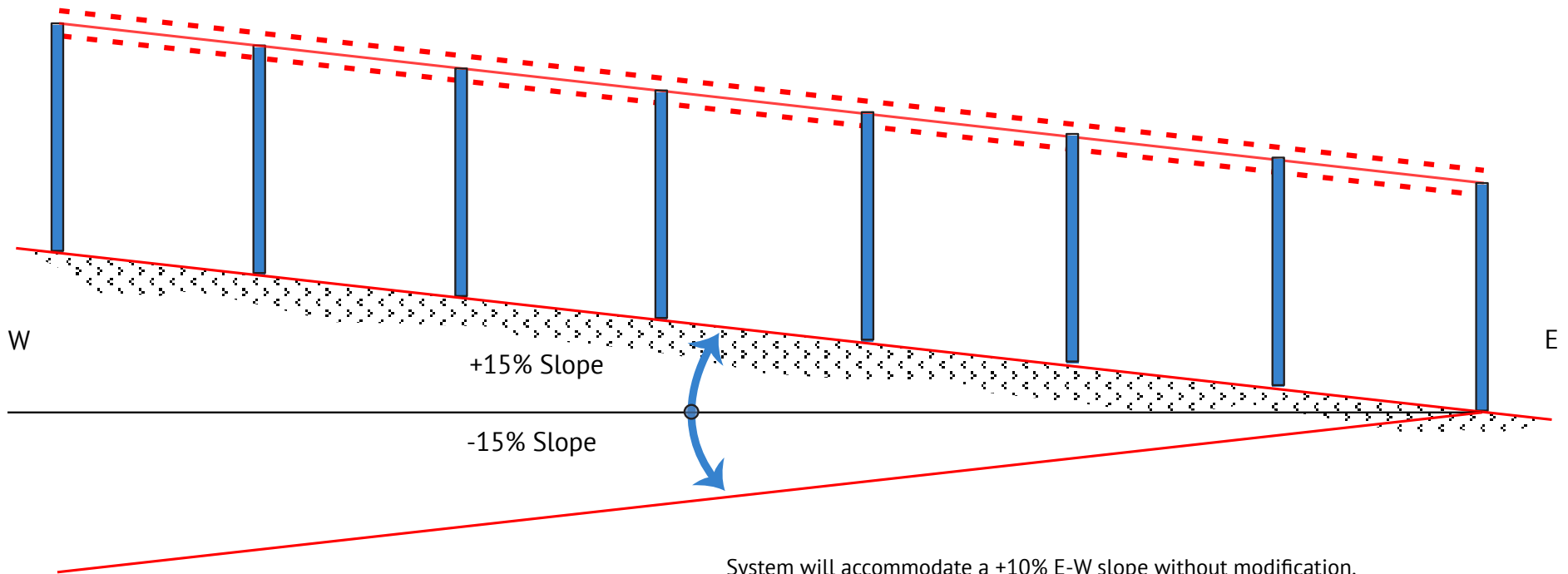

- System will accommodate a $\pm 10\%$ E-W slope without modification.
- Plumb tolerances apply regardless of slope.
 - Pile position tolerances apply relative to nominal finish grade line.

Note:

The GFT system has been installed at an E-W slope of 15%. This is achievable, but requires additional effort to ensure that holes align for bolted connection.

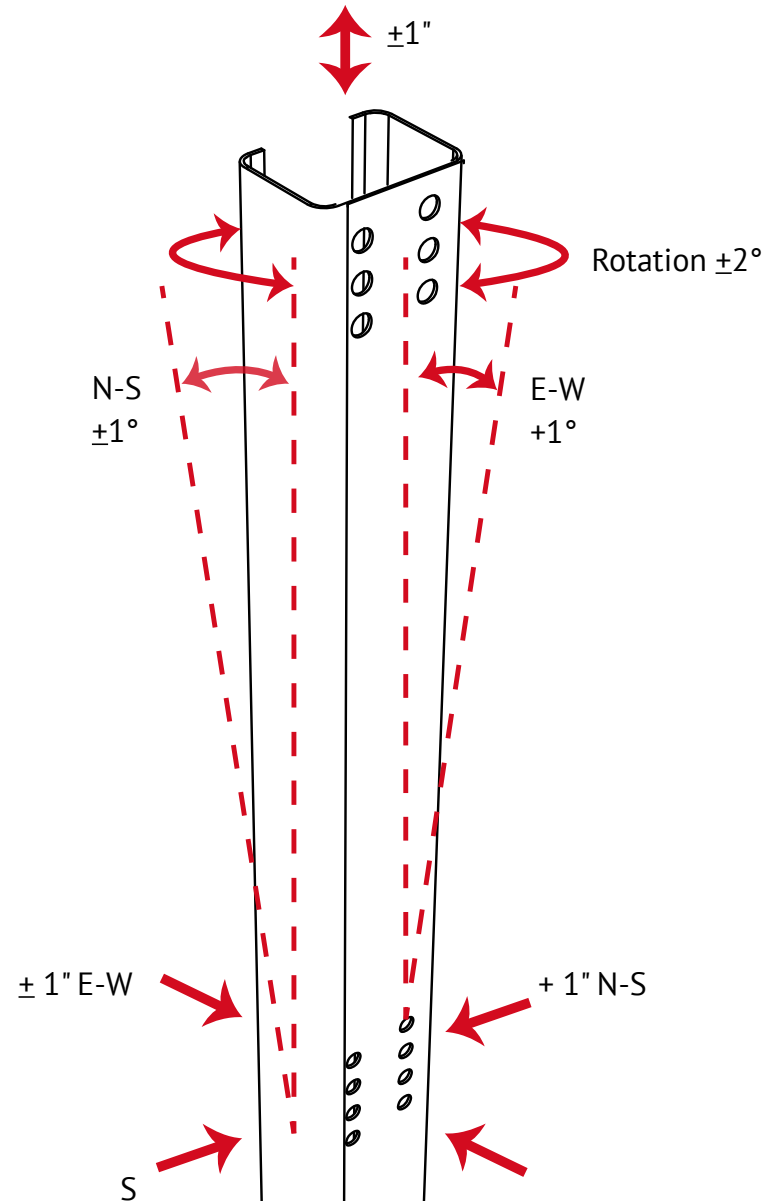

1. Align target hole locations in all piles (within tables and table to table) using laser or string line.
2. Determine if adjustments are needed up or down (hole patterns allow for + 1-1/2" adjustments in 3/4" increments per instruction on following pages).
3. Mark holes to be used for top chord and diagonal brace plate attachments prior to installing.

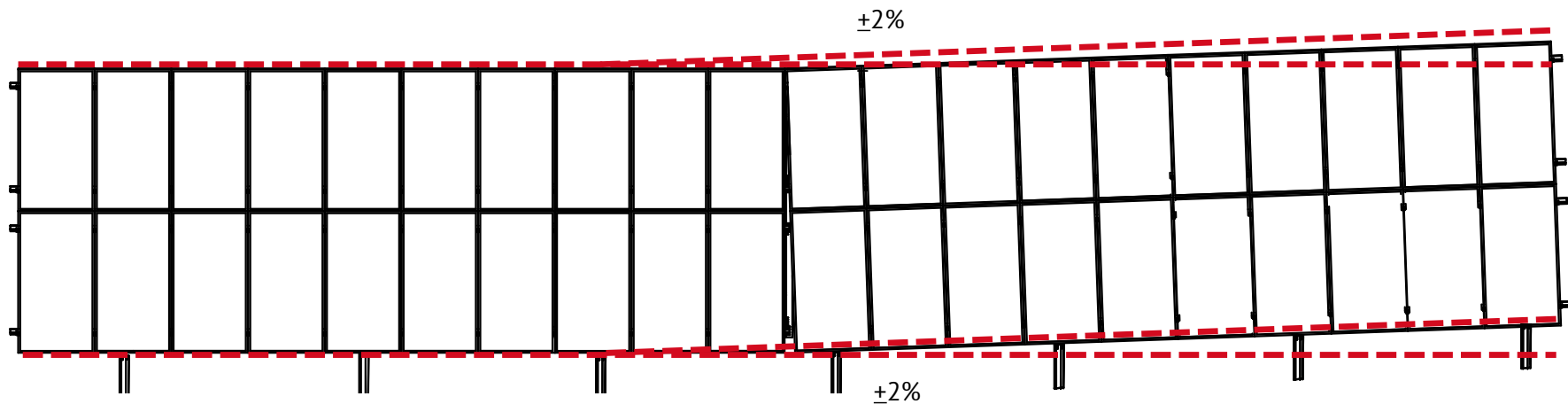
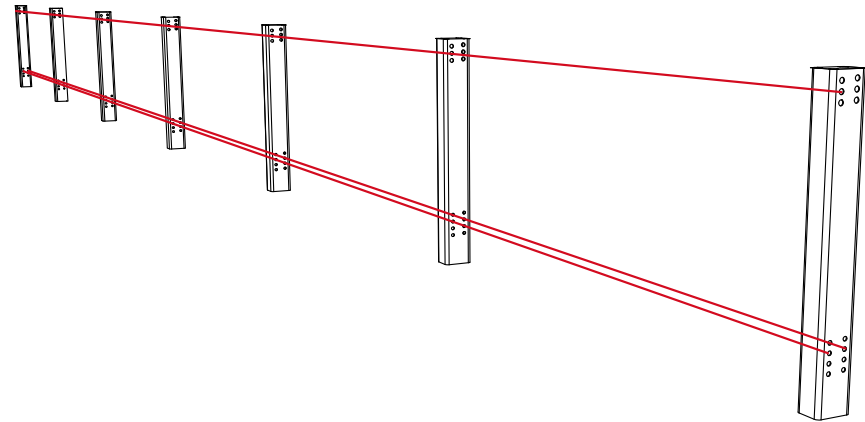

The system is capable of being aligned to the target string or laser line using the adjustment holes when piles are placed within allowable tolerances. Each table will however accommodate a 2% deviation from the target line as shown without impact to structural integrity.

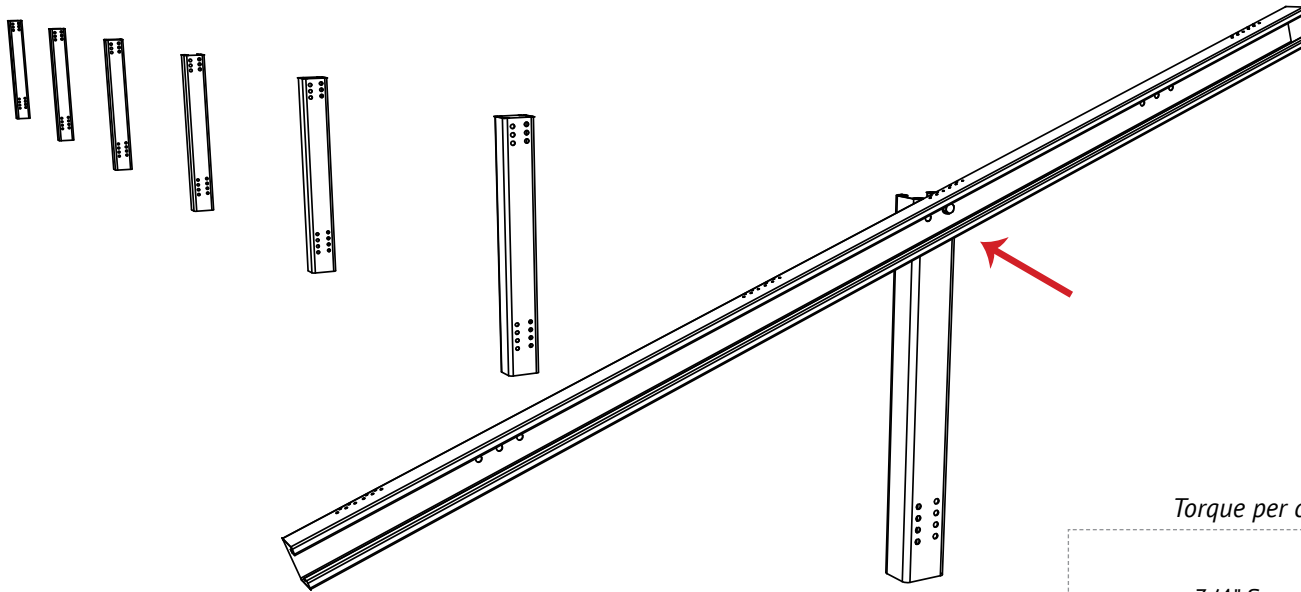

Install hardware snug tight.
Torque per construction drawings after final adjustments.

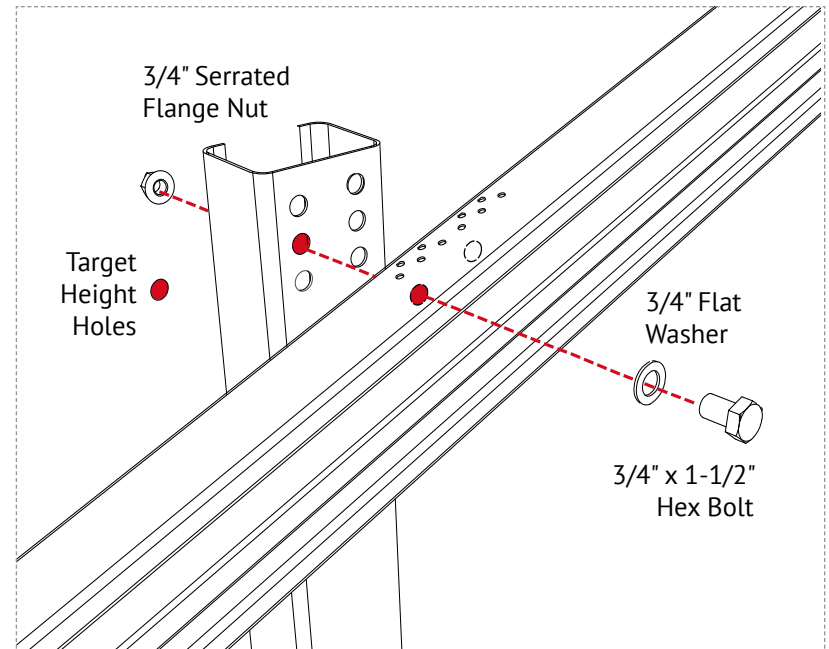

Target Height

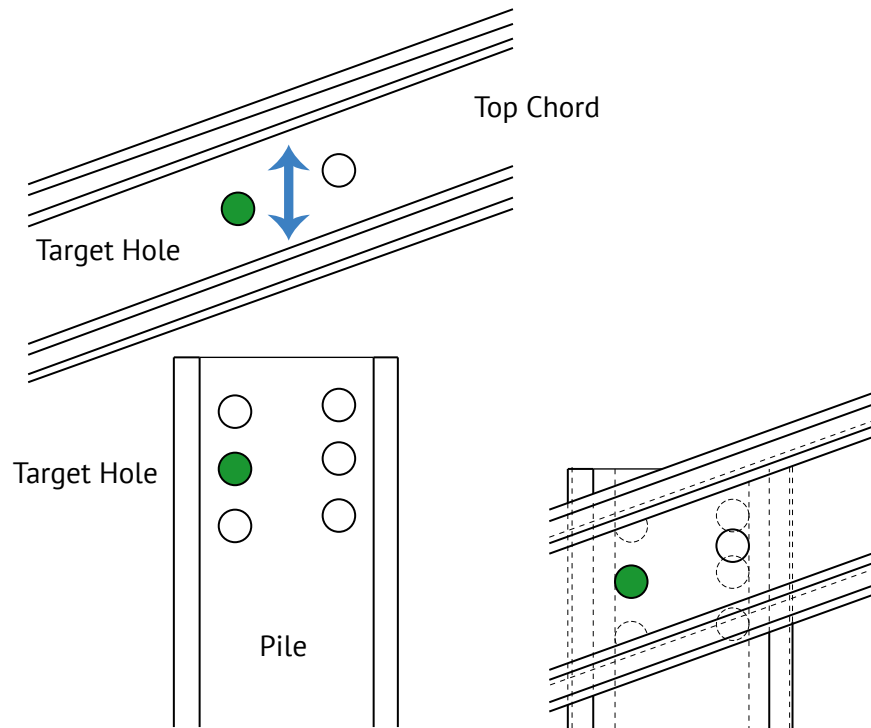

Move top chord up or down (not horizontally) as needed to adjust height in 3/4" increments.

Use single 3/4" bolt (nut and washer) at one of the locations shown.

Adjustment Locations (Single 3/4" Bolt)

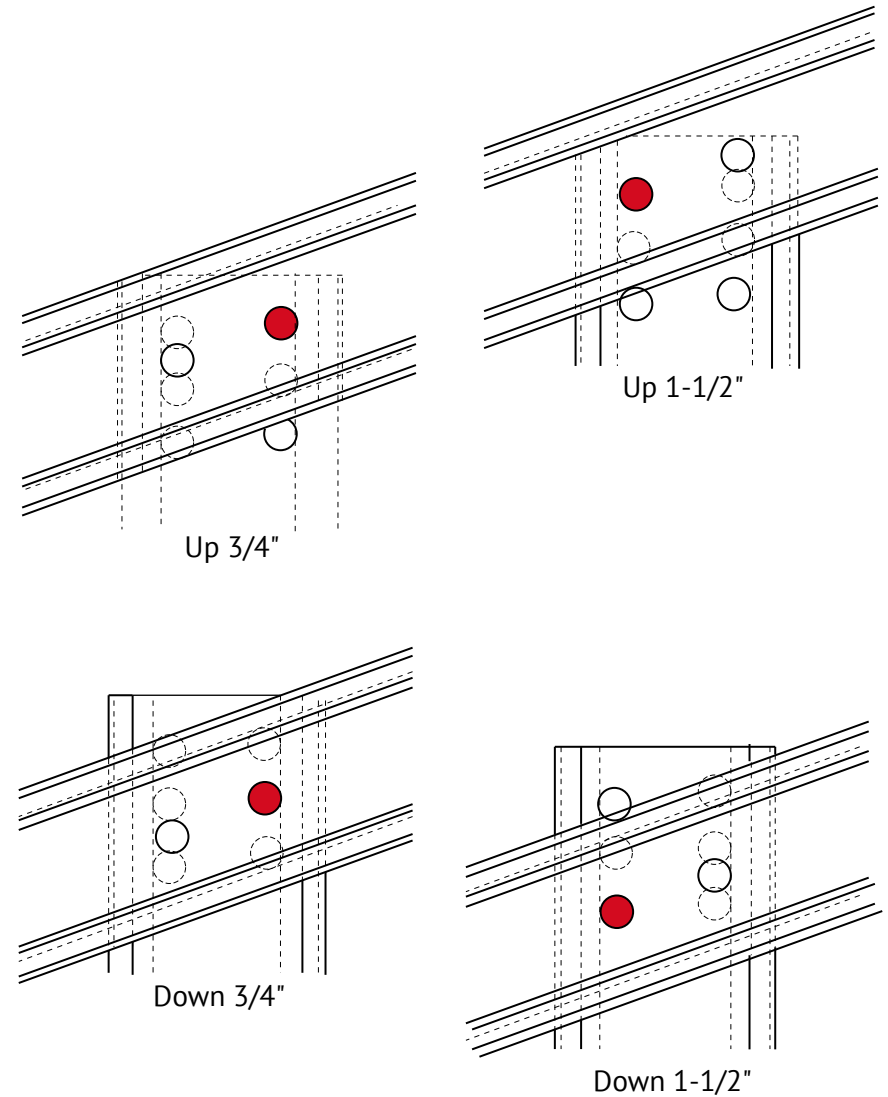

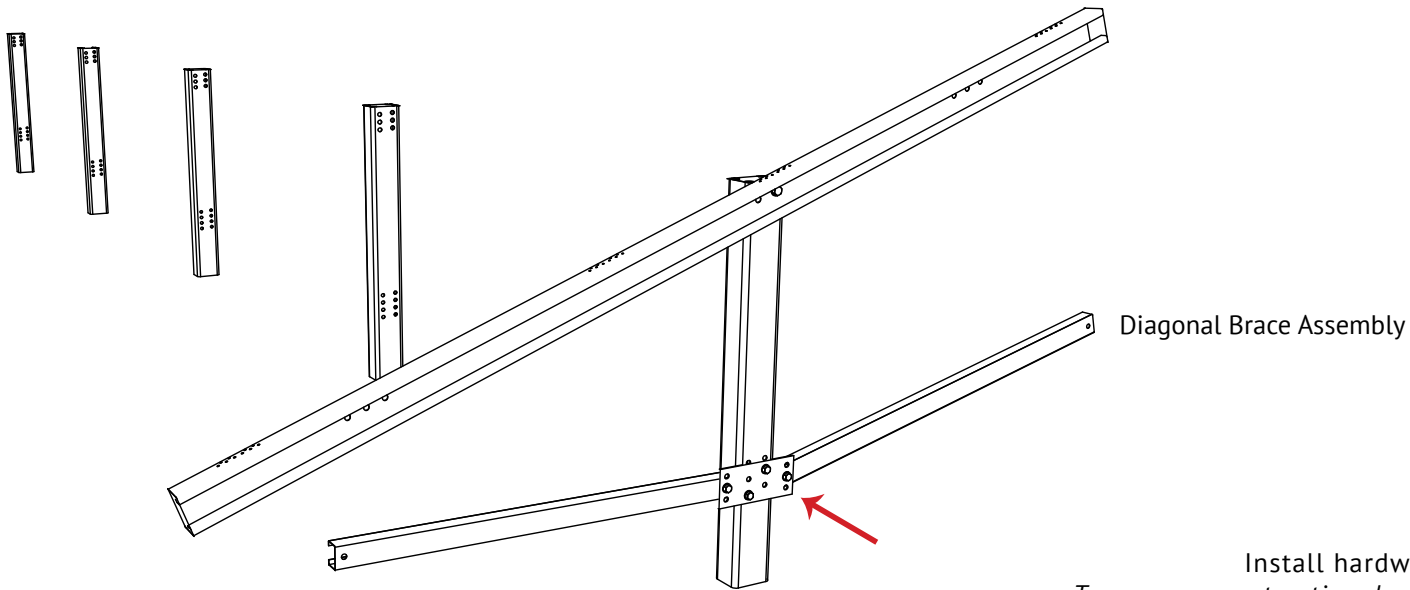

Install hardware snug tight.
Torque per construction drawings after final adjustments.

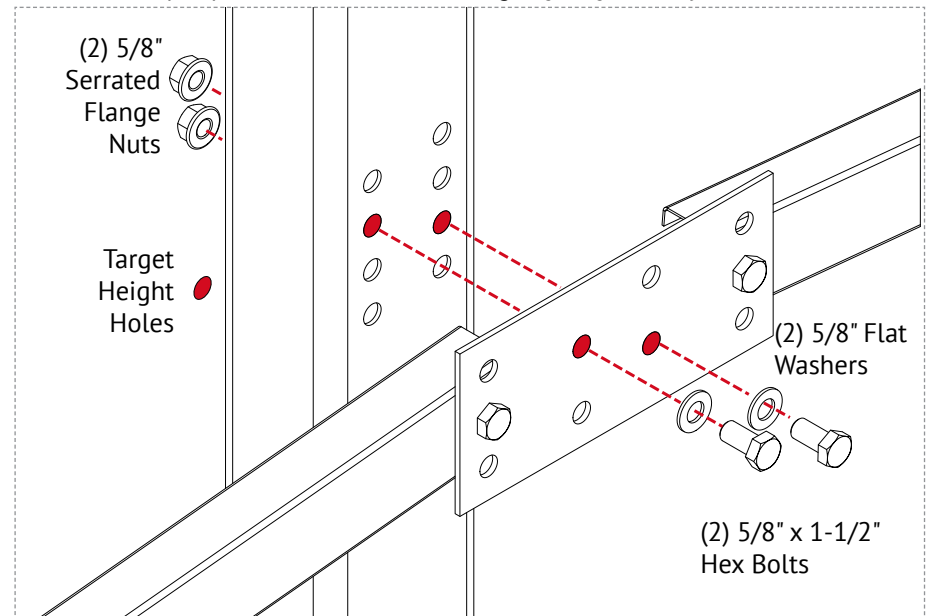

Target Height

Move diagonal brace plate up or down (not horizontally) as needed to adjust height in 3/4" increments.

Use pair of 5/8" bolts (nuts and washers) at location shown.

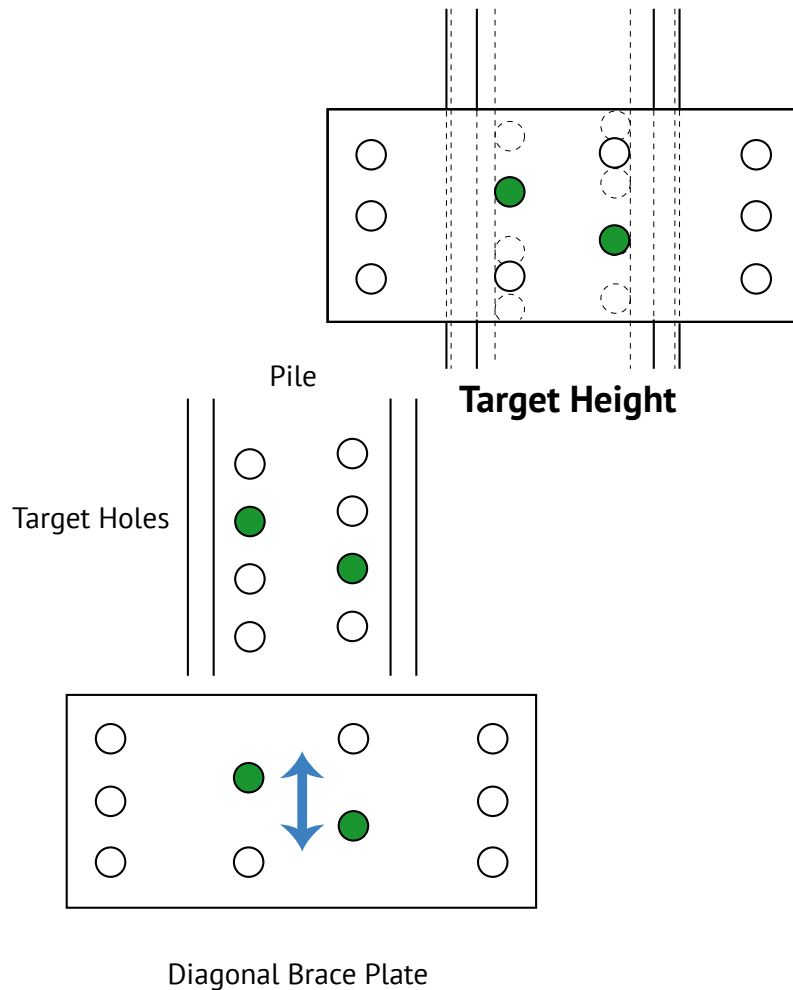

Adjustment Locations (Pair of 5/8" Bolts)

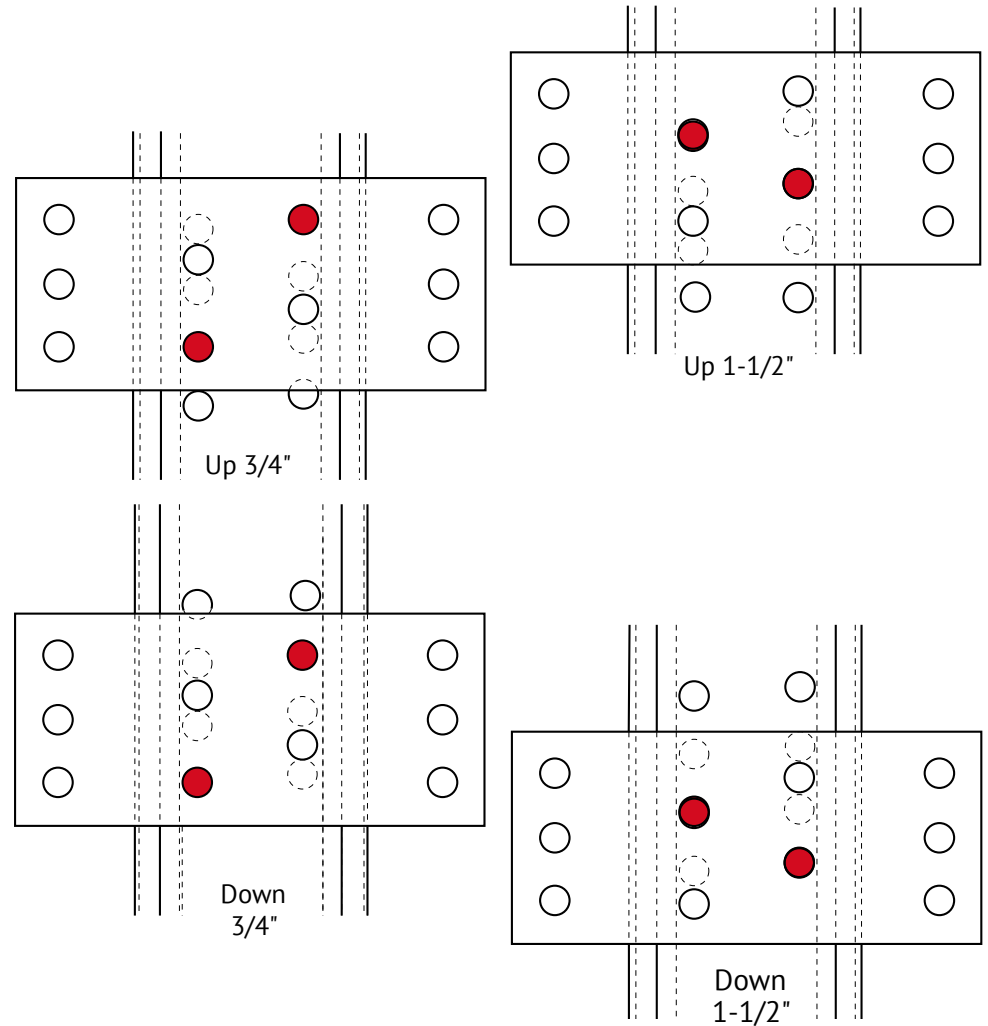

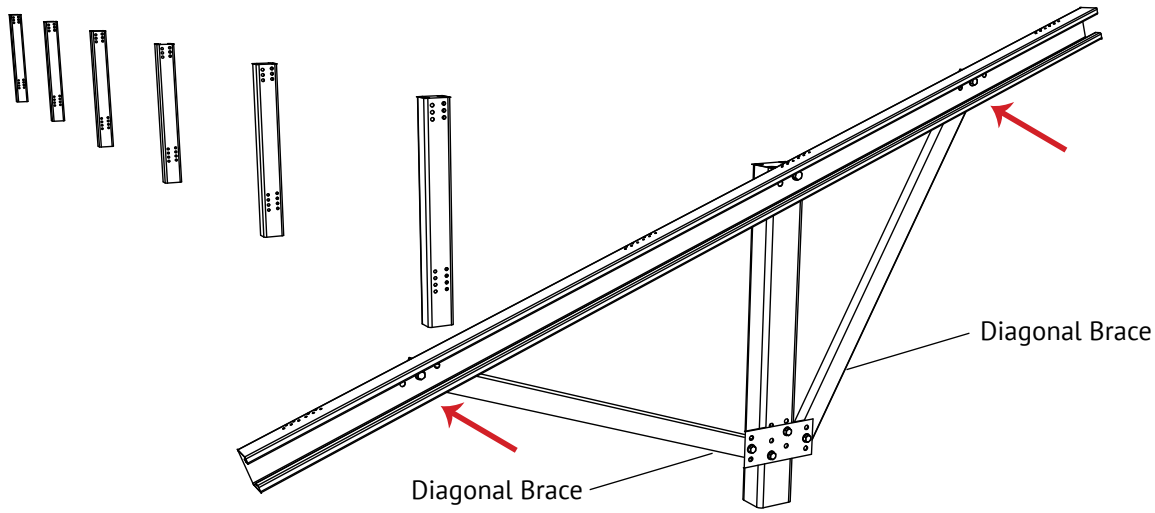
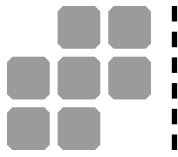

Install hardware snug tight.
Torque per construction drawings after final adjustments.

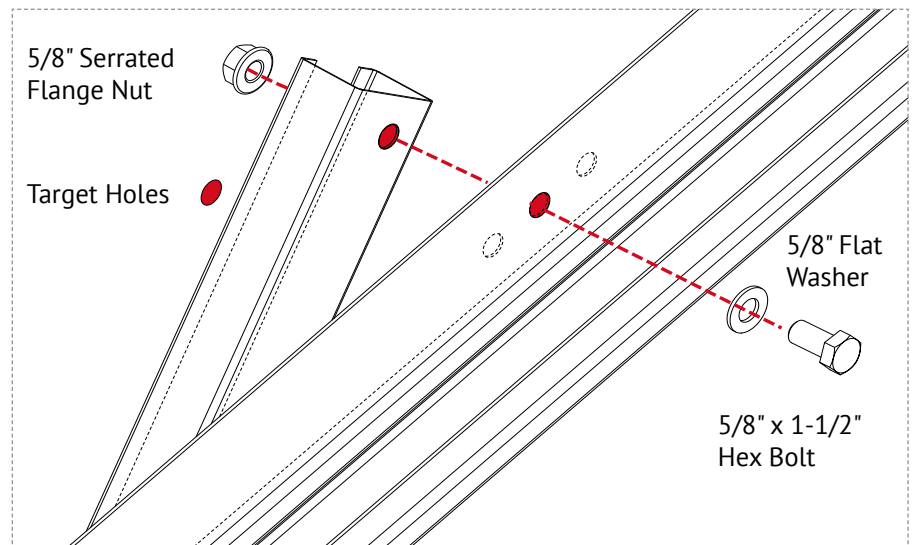



Torque all bolts after final adjustments.
Refer to Torque values stated on page B of the
installation manual and in the general notes
section of the construction drawings.

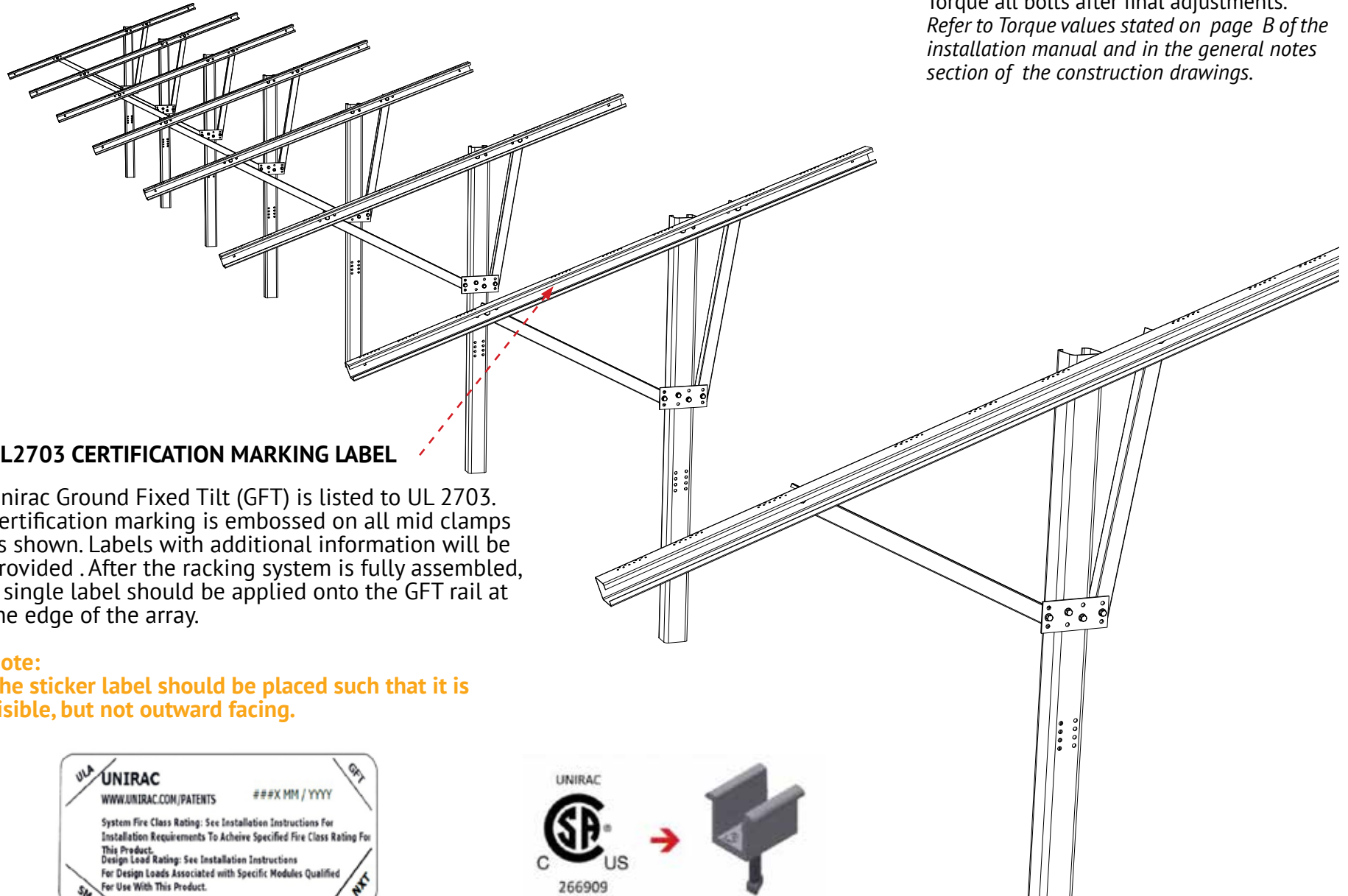

UL2703 CERTIFICATION MARKING LABEL

Unirac Ground Fixed Tilt (GFT) is listed to UL 2703. Certification marking is embossed on all mid clamps as shown. Labels with additional information will be provided. After the racking system is fully assembled, a single label should be applied onto the GFT rail at the edge of the array.

Note:
The sticker label should be placed such that it is visible, but not outward facing.



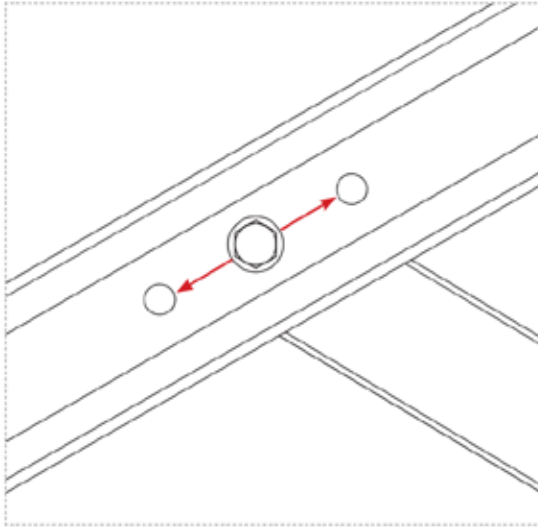

If required, additional minor adjustment of top chord angle may be achieved by a combined repositioning of diagonal braces to adjacent holes in top chord and diagonal brace plate.

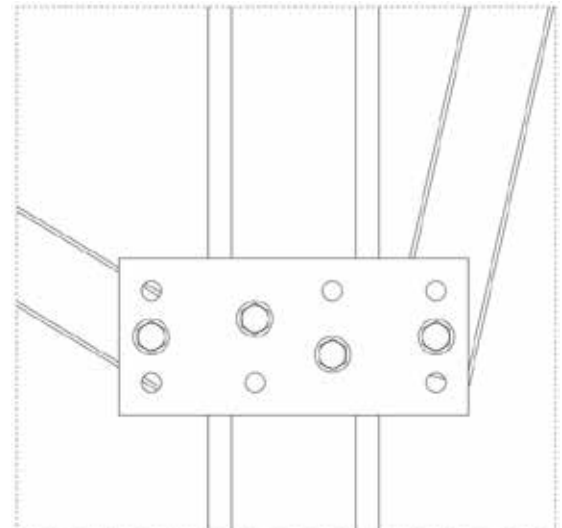
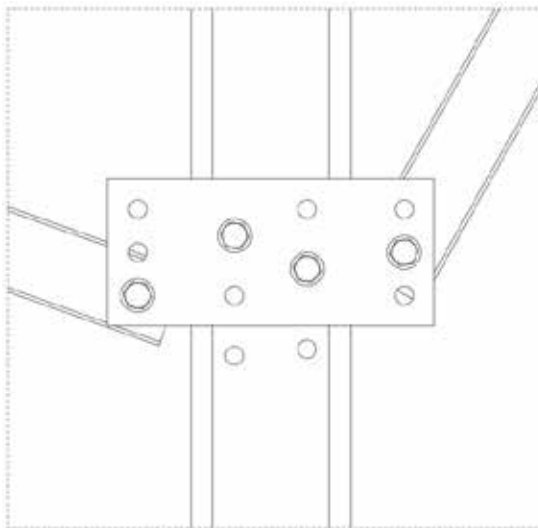
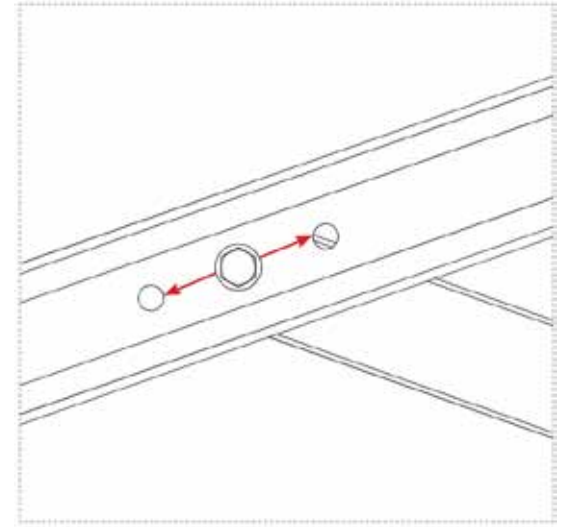

1. Align target hole locations using laser or string line.
2. Determine if adjustments are needed up or down. (hole patterns allow for +1" adjustment in 1/2" increments per instruction on following pages).
3. Mark holes to be used for attaching E-W beams prior to installing.

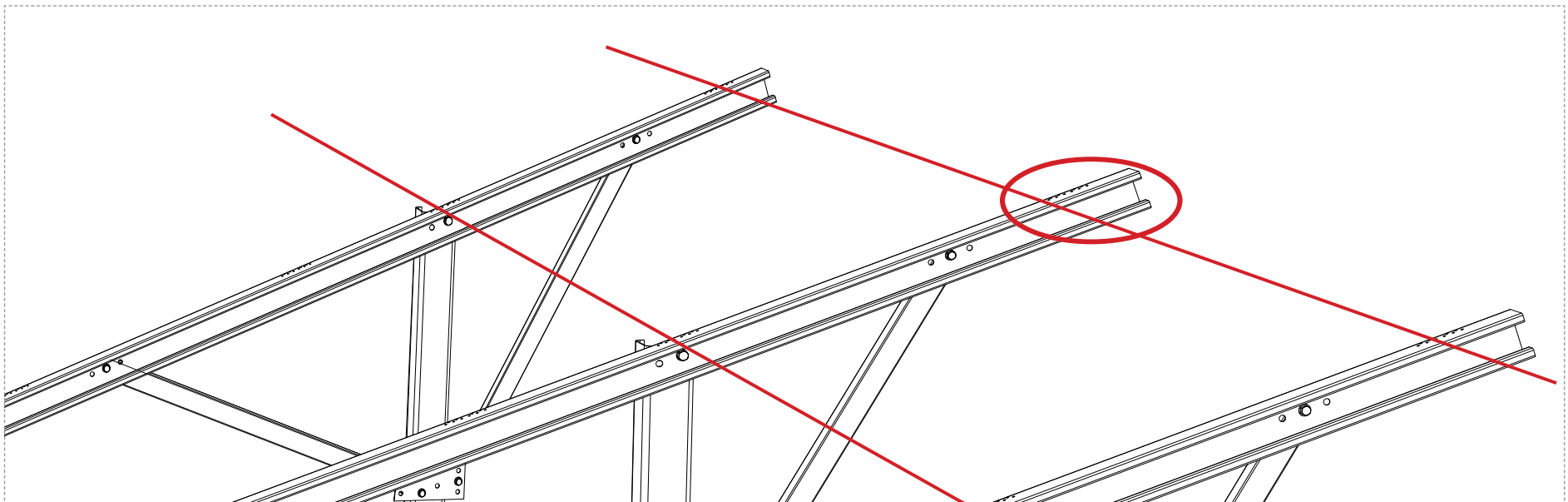
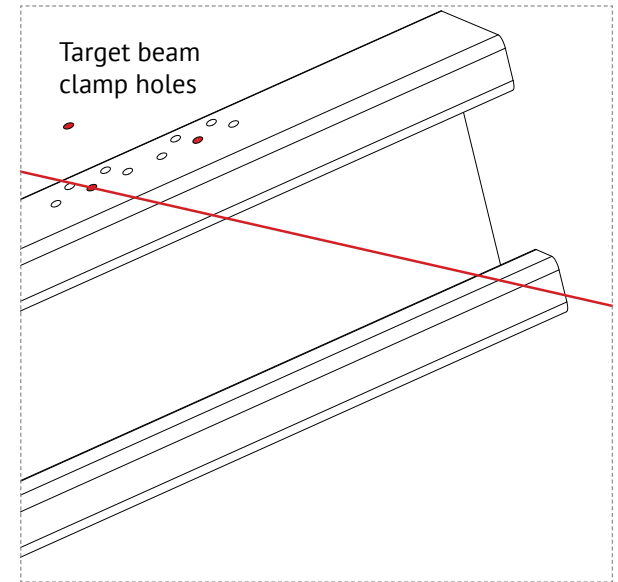

Anti-Seize

Stainless steel hardware can seize up, a process called galling. To significantly reduce its likelihood: 1. Apply minimal lubricant to bolts only where indicated in installation process, preferably Anti-Seize commonly found at auto parts stores (Anti-seize has been factory applied to mid clamp bolts) 2. Shade hardware prior to installation, and 3. Avoid spinning stainless nuts onto bolts at high speed.

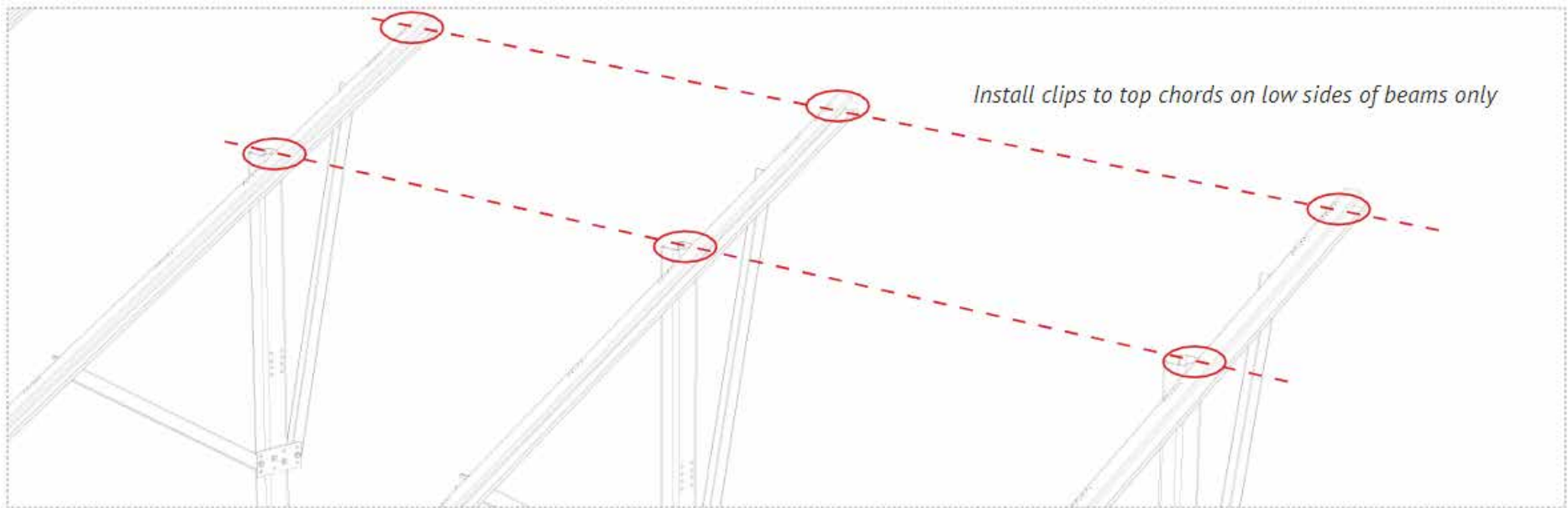
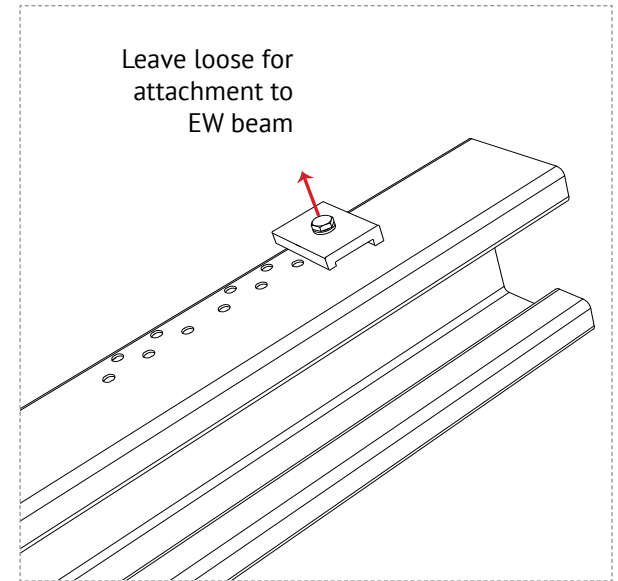
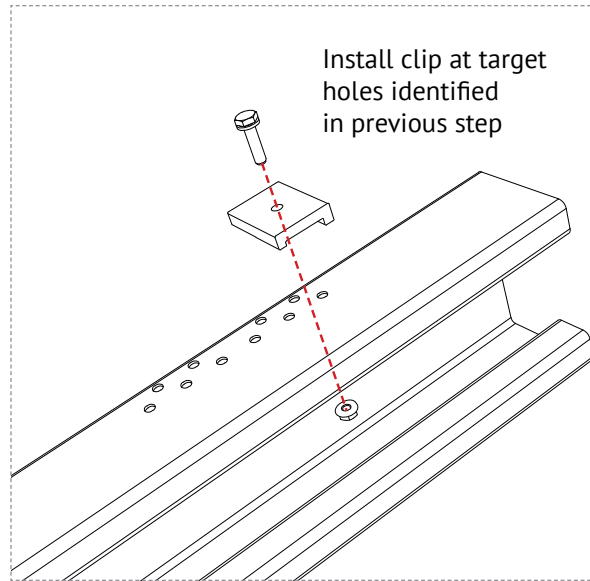

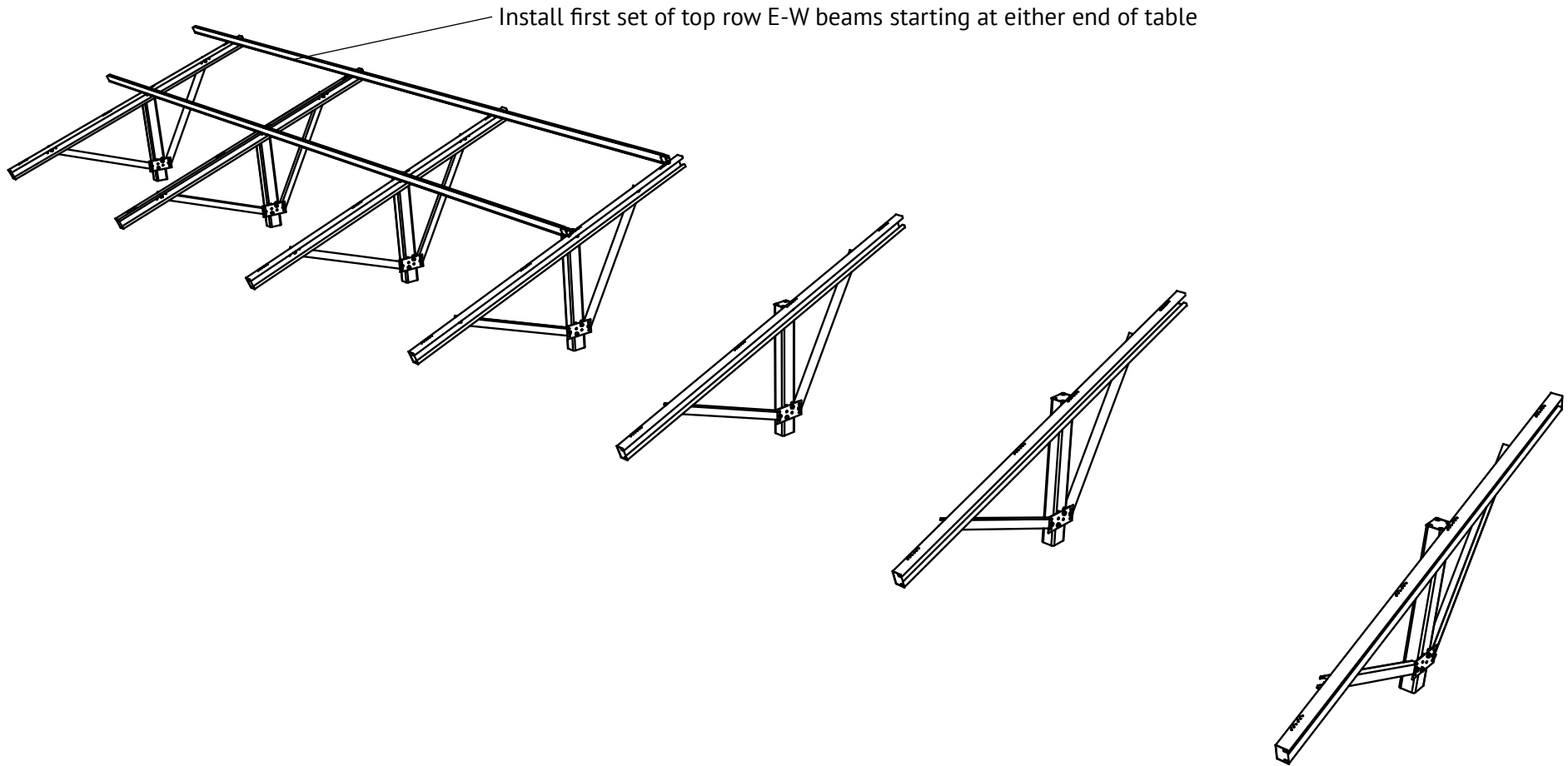

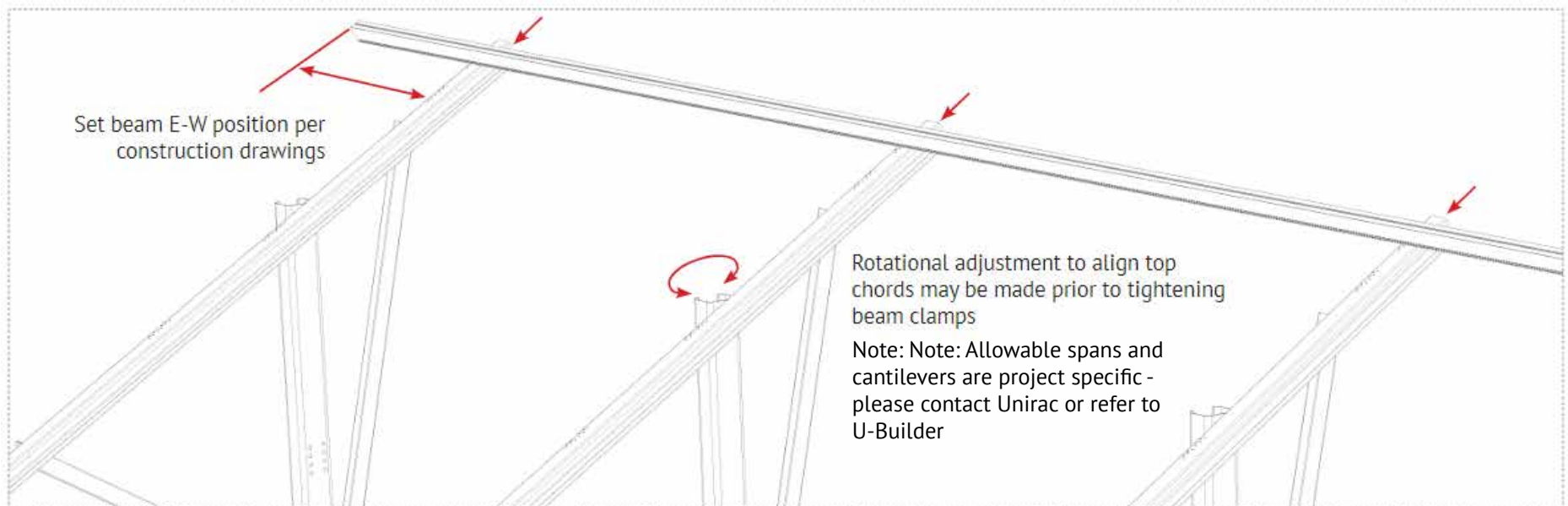
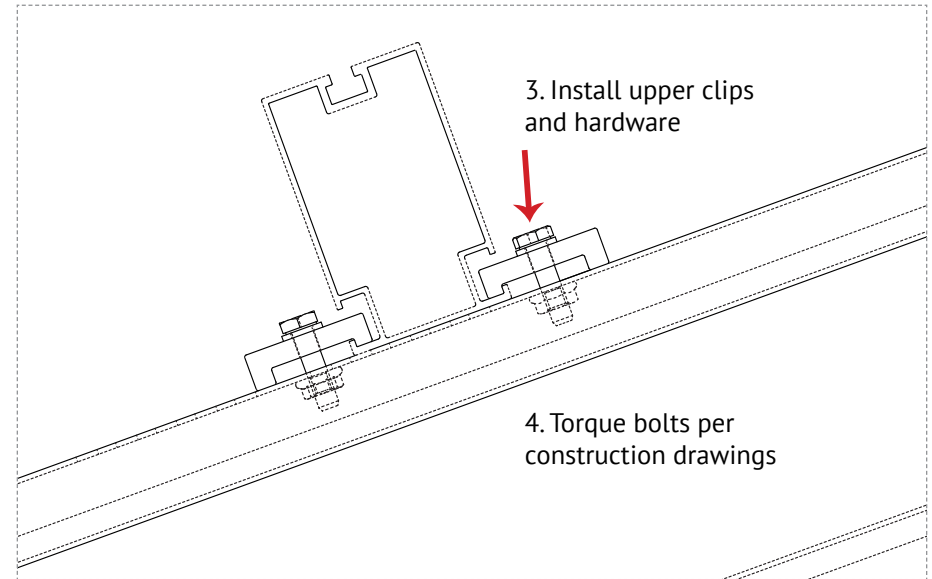
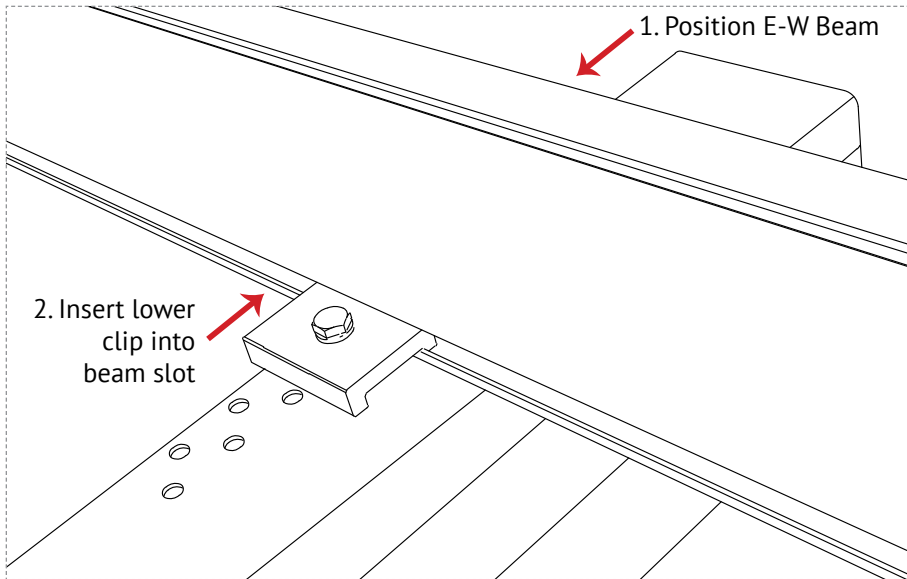

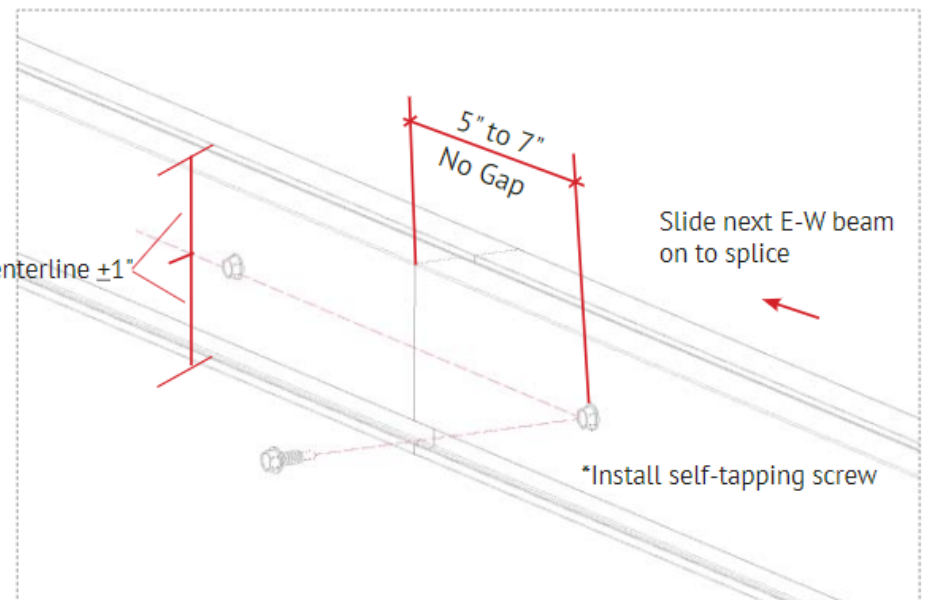
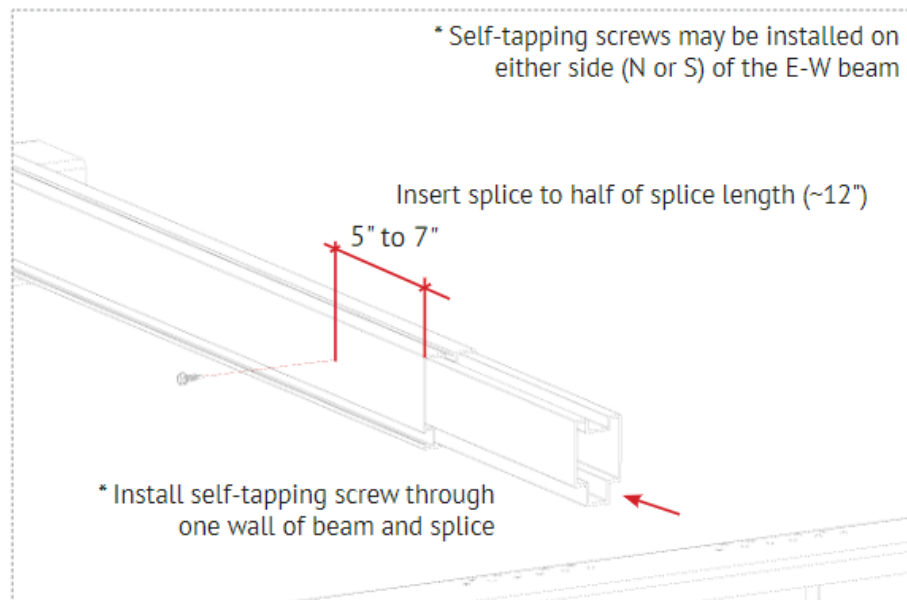
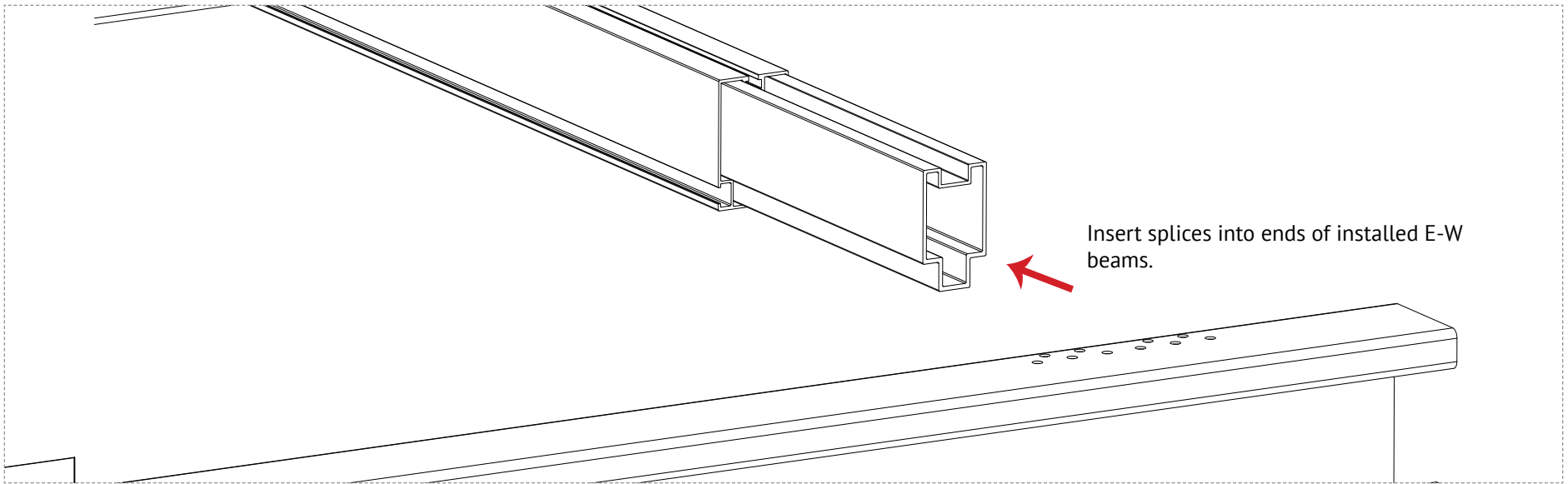

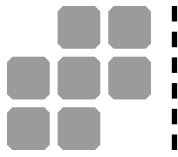

GFT GROUND
FIXED
TILT

COMPLETE
TOP ROW **E-W BEAM INSTALLATION**

17

INSTALLATION GUIDE : PAGE

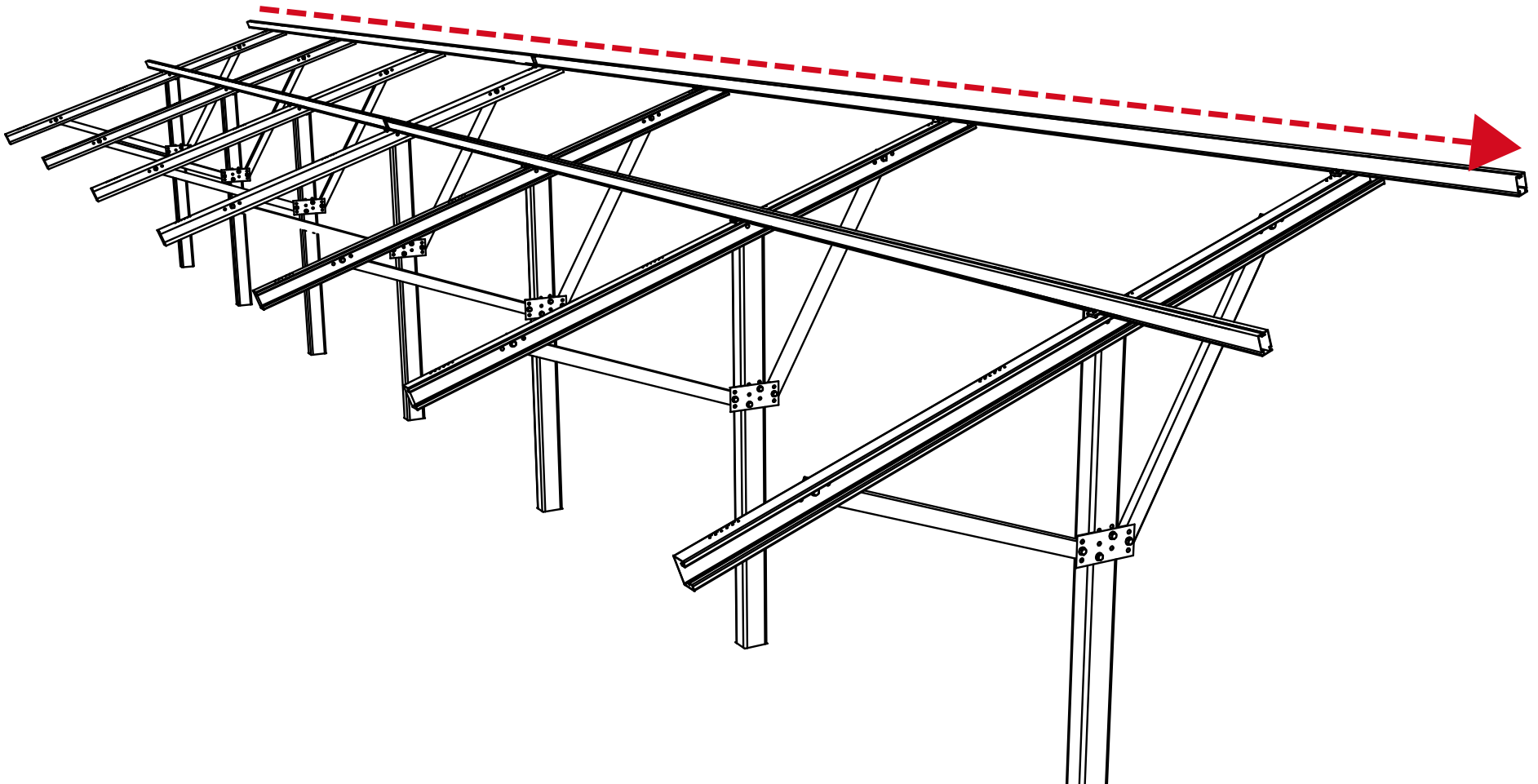

Mid Clamp Assembly with T-Bolt

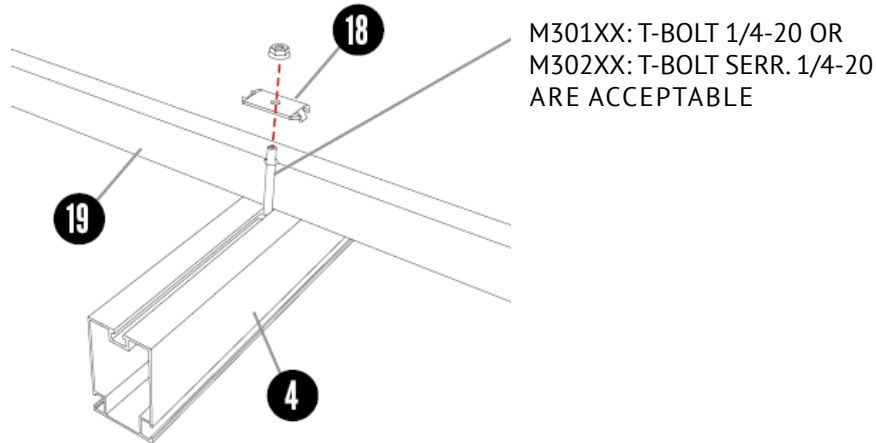

End Clamp Assembly with T-Bolt

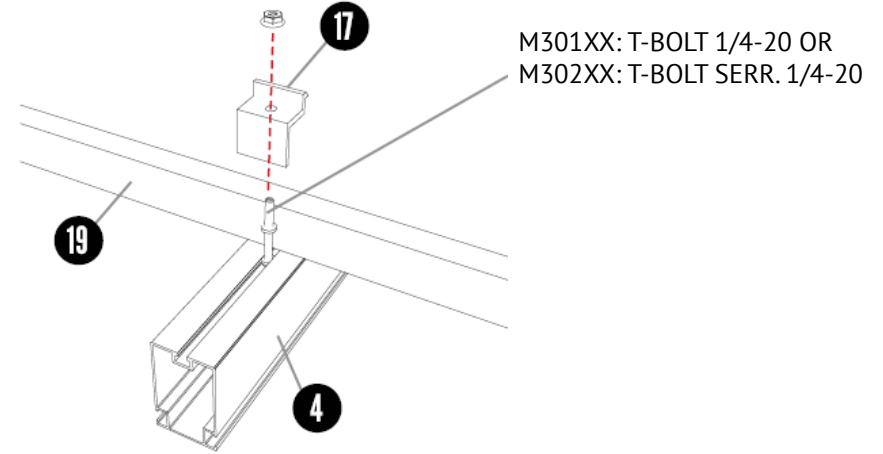

Mid Clamp Assembly With T-Bolt

ITEM	COMPONENT	MATERIAL
4	3.25" x 2" East-West Aluminum Beam	Aluminum Alloy 6005A-T61, 6351-T5 or 6061-T6
18	Mid Clamp	Stainless Steel, 301,302, or 304, 1/4 Hard, Mill Finish
19	PV Module (By Others)	As per Manufacturer
SEE DWG	1/4-20 T-Bolt (Serrated or Non-Serrated)	300 Stainless Steel (301 Preferred)
SEE DWG	1/4-20 Serrated Flange Nut	Stainless Steel ASTM F594

End Clamp Assembly With T-Bolt

ITEM	COMPONENT	MATERIAL
4	3.25" x 2" East-West Aluminum Beam	Aluminum Alloy 6005A-T61, 6351-T5 or 6061-T6
17	End Clamp	Stainless Steel, 301,302, or 304, 1/4 Hard, Mill Finish
19	PV Module (By Others)	As per Manufacturer
SEE DWG	1/4-20 T-Bolt (Serrated or Non-Serrated)	300 Stainless Steel (301 Preferred)
SEE DWG	1/4-20 Serrated Flange Nut	Stainless Steel ASTM F594

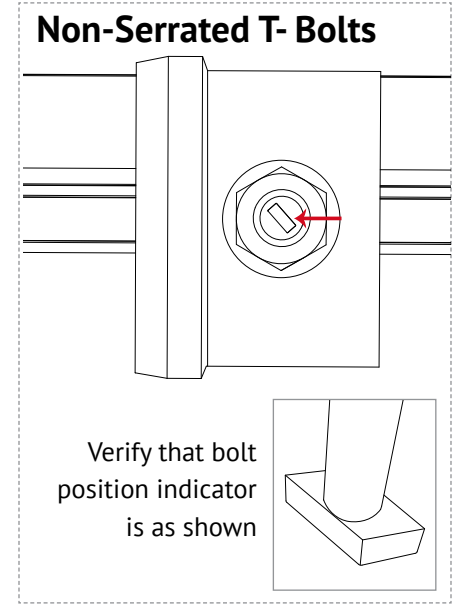
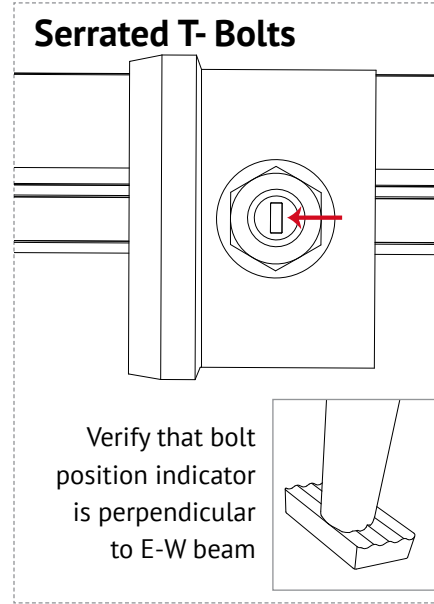
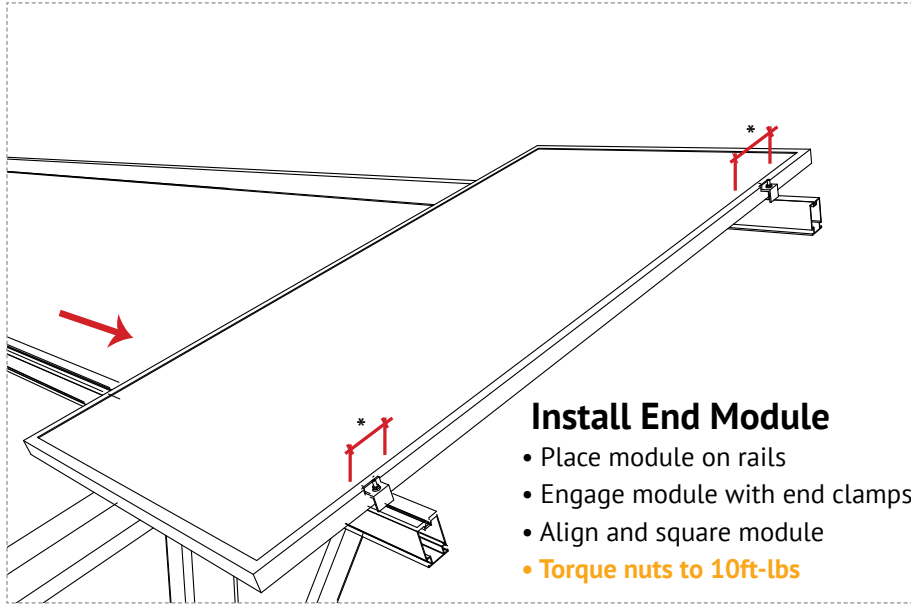
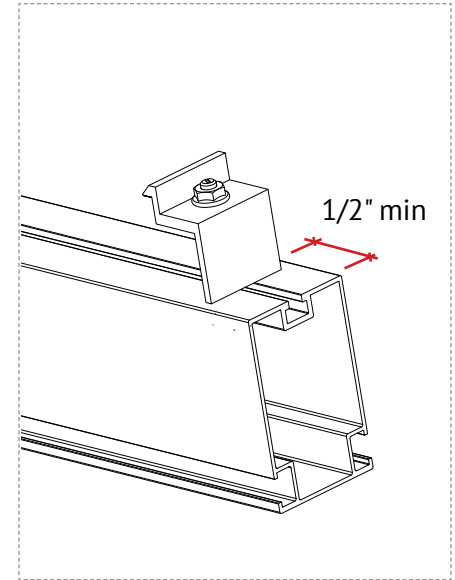
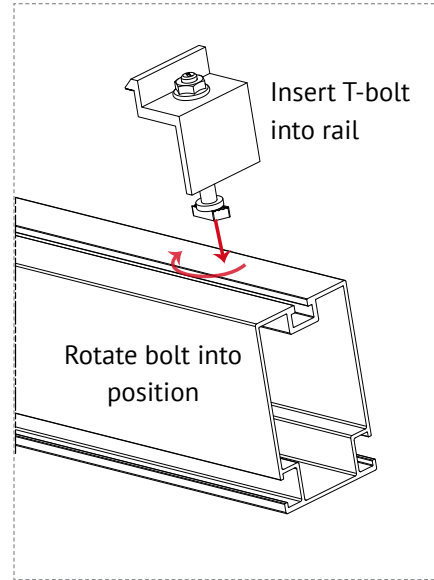
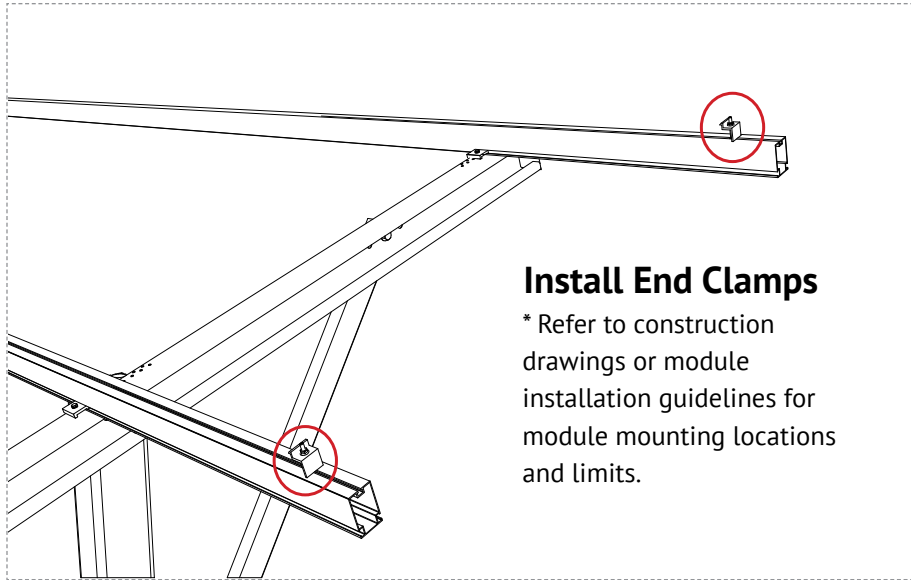

NOTE: *See appendix for different clamp configurations.

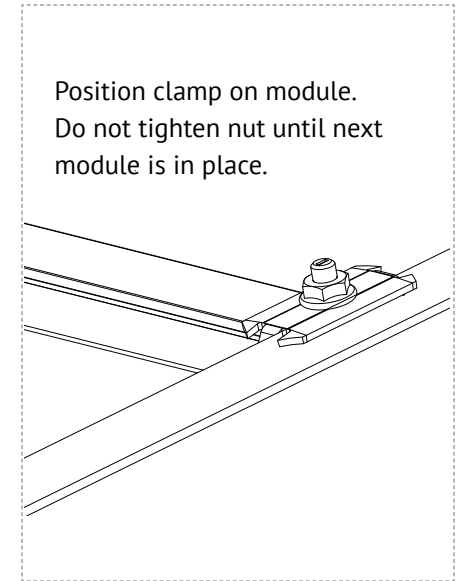
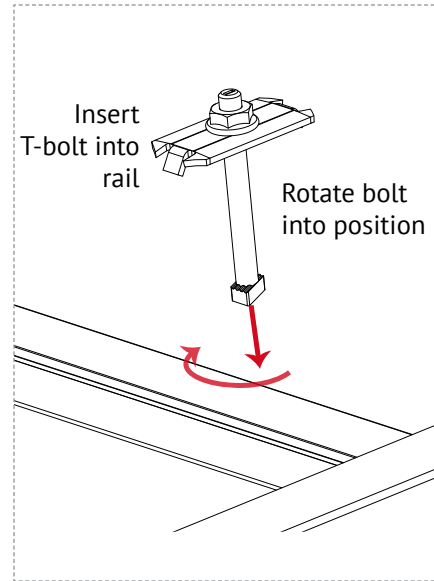
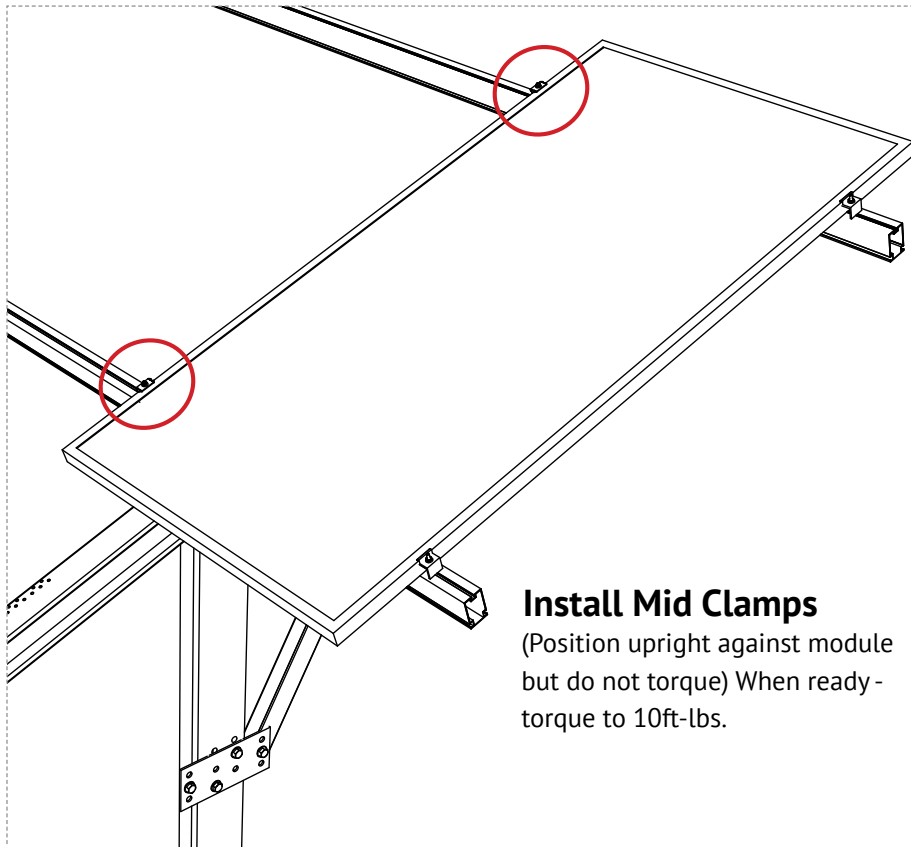

Serrated T- Bolts

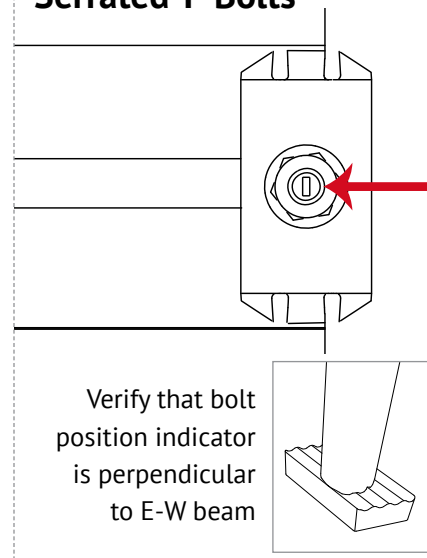

Non-Serrated T- Bolts

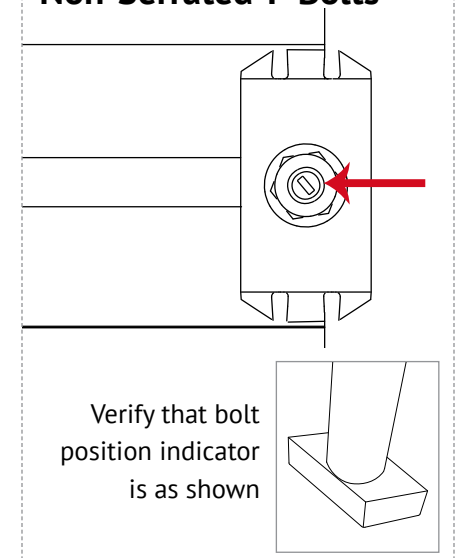

NOTE: *See appendix for different clamp configurations.

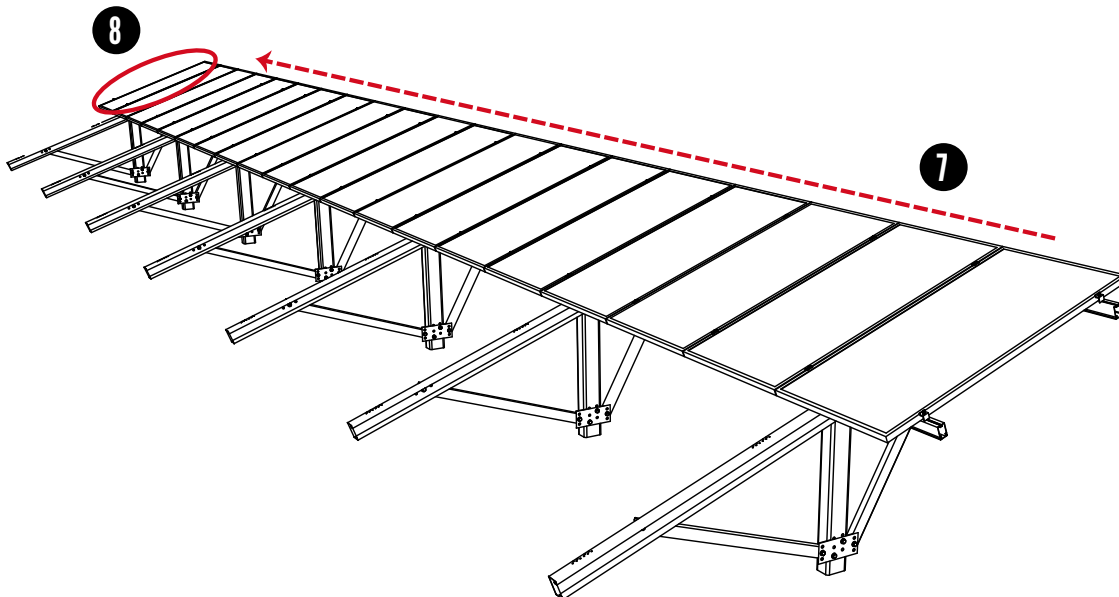
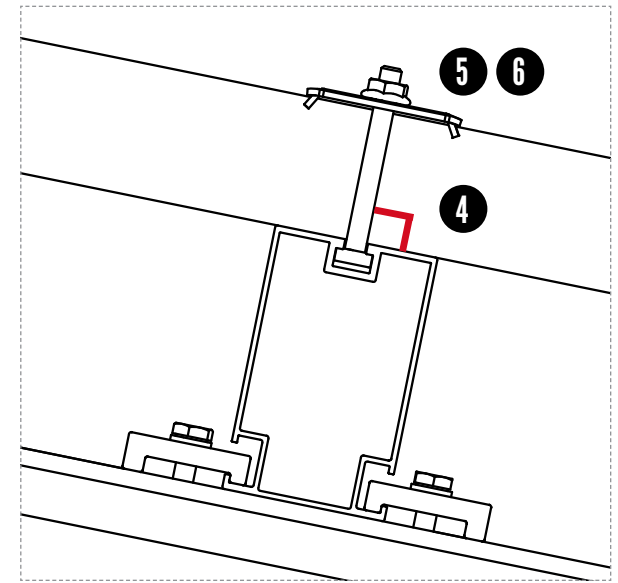
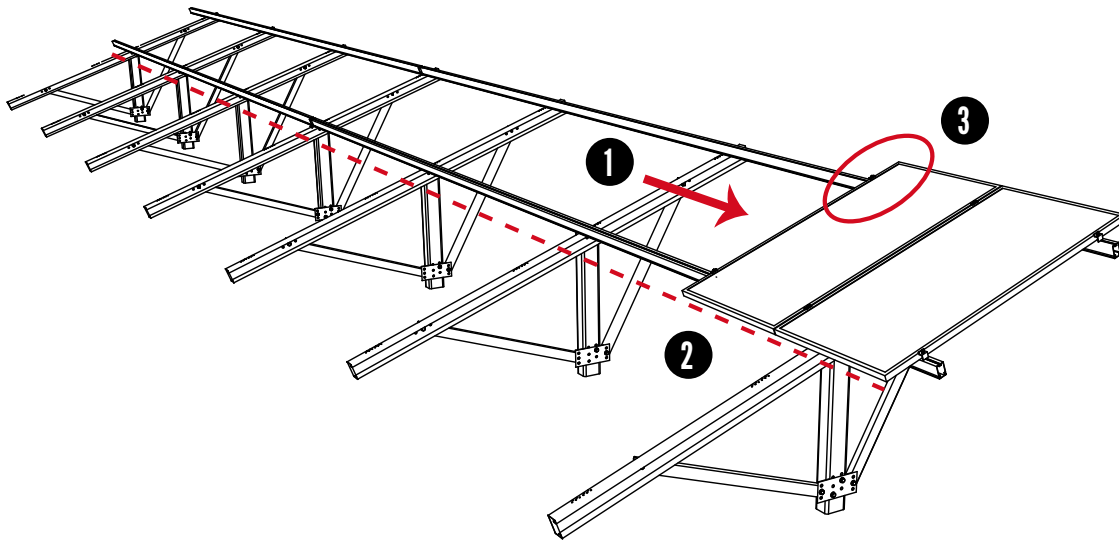

1. Place module on rails and engage with Mid Clamps
2. Align and square modules
3. Verify module gap (1/4")
4. Verify Mid Clamp bolt shafts are perpendicular to rail
5. Verify position of indicator mark on bolt
6. Torque nuts to 10 ft-lbs
7. Repeat installation of clamps and modules to complete top row
8. Install End Clamps on last module

NOTE: The GFT system must be periodically re-inspected for loose components, loose fasteners and any corrosion, such that if found, the affected components are to be immediately replaced.



GFT GROUND
FIXED
TILT

REPEAT
INSTALLATION OF **E-W BEAM ON BOTTOM ROW**

22

INSTALLATION GUIDE : PAGE

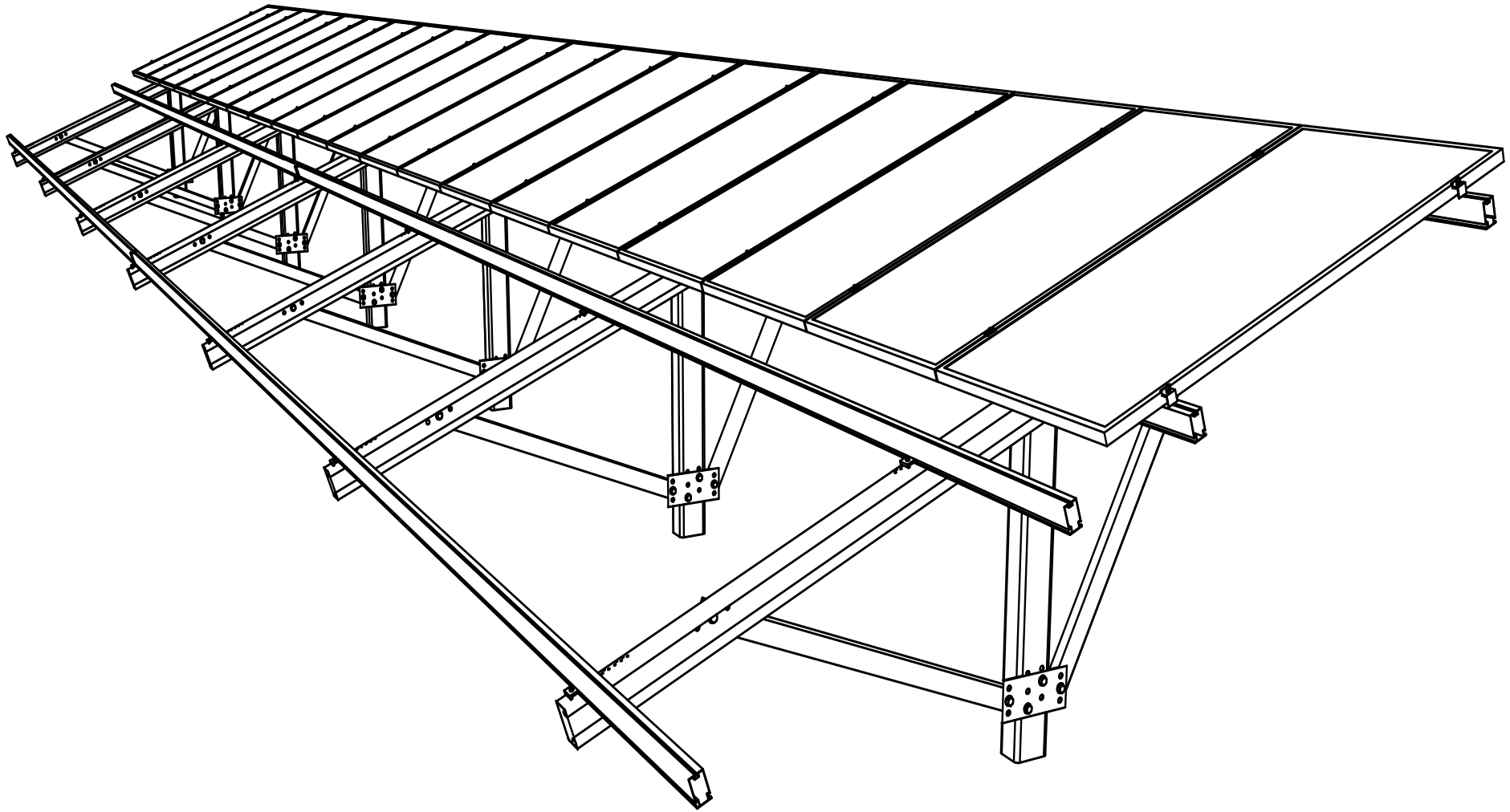



GFT GROUND
FIXED
TILT

REPEAT
INSTALLATION OF

MODULES ON BOTTOM ROW

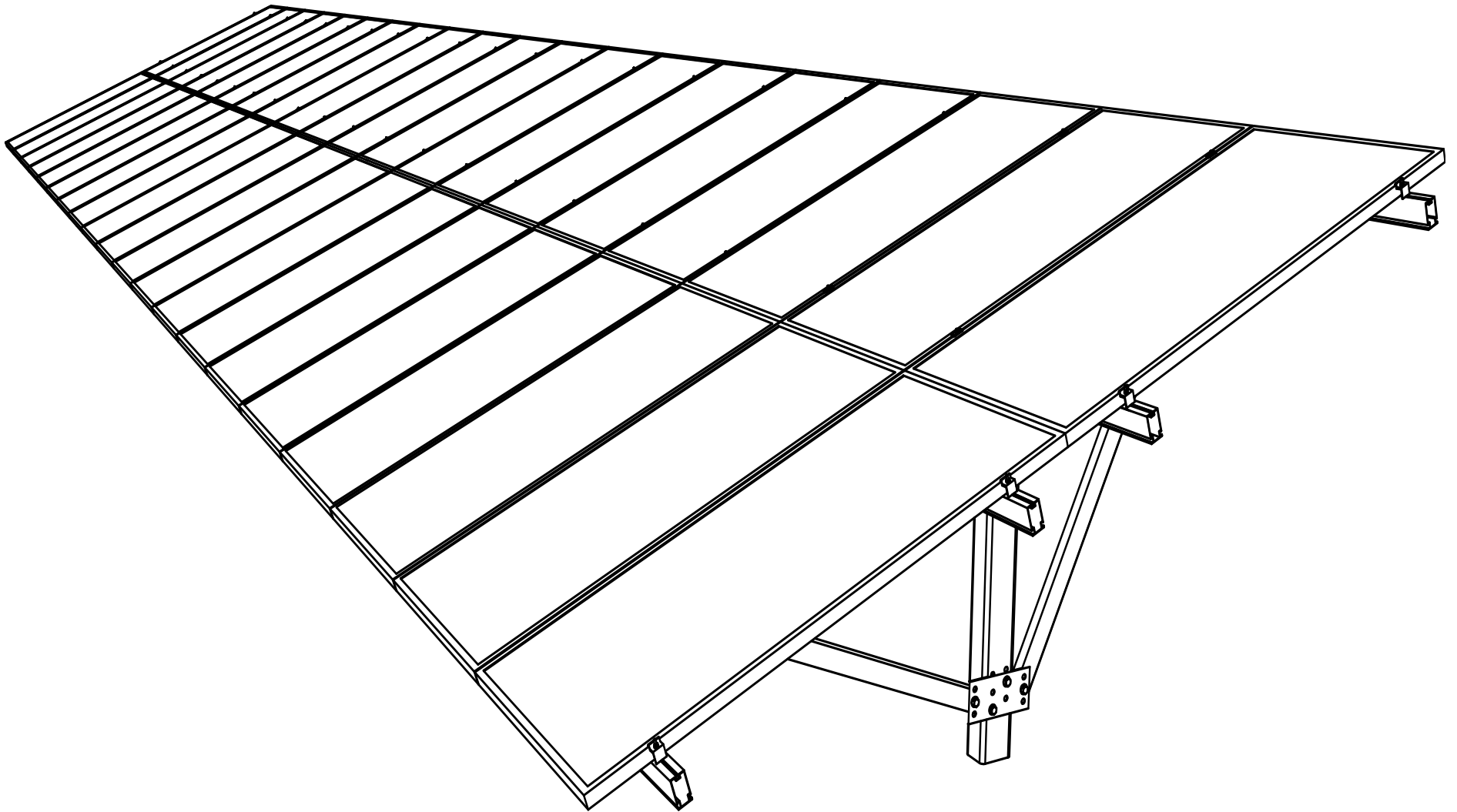

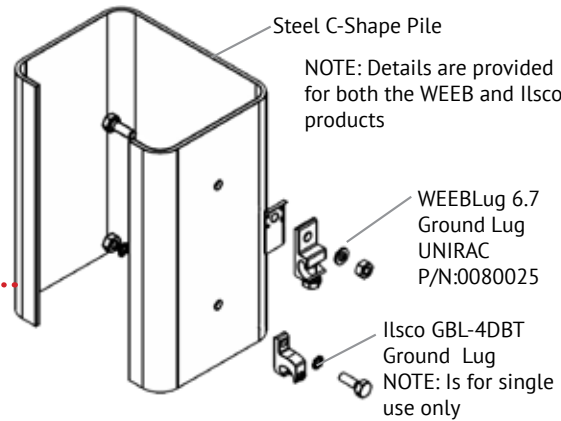
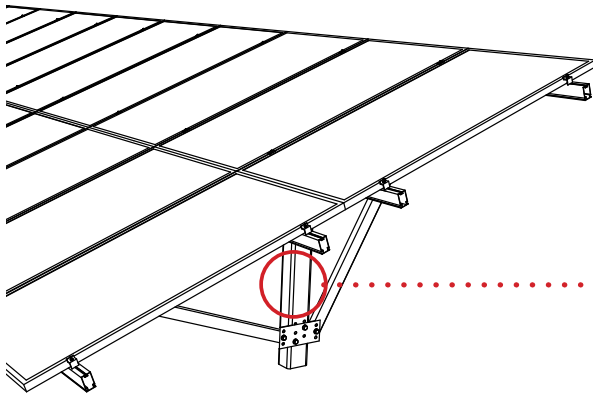

The following grounding & bonding components have been certified to be compatible with Unirac GFT:

- Wiley WEEBLug (P/N 0080025) Torque 1/4" mounting hardware to 10ft-lbs. See product data sheet for conductor size and conductor fastener torque.
- IIsco Lay-in Lug (P/N GBL-4DBT) Torque 10-32 mounting hardware to 5ft-lbs. See product data sheet for conductor size and conductor fastener torque.

Ground Lug	Bolt size	Drill size
WEEBLug	1/4"-20	17/64"
IIsco	#10-32	7/31"

The entire Unirac GFT table has been classified for grounding & bonding to UL2703. The bonding path has been evaluated from the PV module frame all the way through to the pile. The following are suggestions to aid in grounding The entire Unirac GFT table has been classified for grounding & bonding to UL2703. The bonding path has been evaluated from the PV module frame all the way through to the pile. The following are suggestions to aid in grounding of the table for the project electrical engineer of record, and by the local authority having jurisdiction. This racking system may be used to ground and/or mount a PV module complying with UL1703 only when the specific module has been evaluated for grounding and/or mounting in compliance with the included instructions.

GROUND LUG MOUNTING DETAILS

Details are provided for both the WEEB and IIsco products. The WEEBLug has a grounding symbol located on the lug assembly. The IIsco lug has a green colored set screw for grounding indication purposes. One lug is recommended per GFT table. Installation must be in accordance with NFPA NEC70, however the electrical designer of record should refer to the latest revision of National Electrical Code (NEC) for actual grounding conductor cable size. Unirac GFT is intended to be used with PV modules that have a system voltage less than or equal to that allowable by NEC. A minimum 10AWG, 105°C copper grounding conductor should be used to ground the system according to the (NEC) and the authority having jurisdiction. It is the installers responsibility to check local codes, which may vary. NOTE: Any holes drilled to attach the ground lugs should be de-burred before use. **NOTE: All Unirac module clamps and the IIsco GBL-4DBT ground lug are single use. All other GFT components are multiple use.**

TEMPORARY BONDING CONNECTION DURING ARRAY MAINTENANCE

When removing modules for replacement or system maintenance, any module left in place that is secured with a bonding mid-clamp will be properly grounded. If a module adjacent to the end of a row is removed, or if any other maintenance condition leaves a module without a bonding mid clamp, a temporary bonding connection must be installed as follows:

- Attach IIsco GBL-4DBT or WeebLug 6.7 to both modules on either side of the module that has been removed. Note: The lug should be attached to the manufacturers designated grounding point on the frame.
- Install a solid #6 Awg copper wire to both grounding lugs. **NOTE: ISOLATE COPPER FROM ALUMINUM CONTACT TO PREVENT CORROSION.**

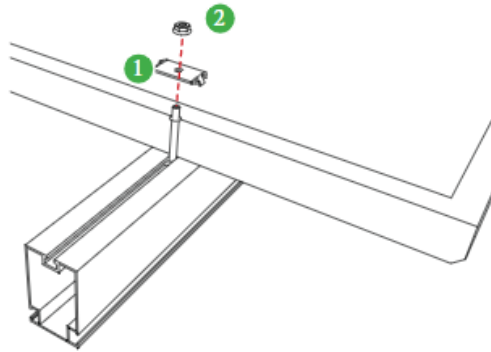

BONDING MIDCLAMP ASSEMBLY

- 1 Stainless steel Midclamp points, 2 per module, pierce module frame anodization to bond module to GFT rail through clamp.
- 2 Serrated flange nut bonds stainless steel clamp to stainless steel T-bolt

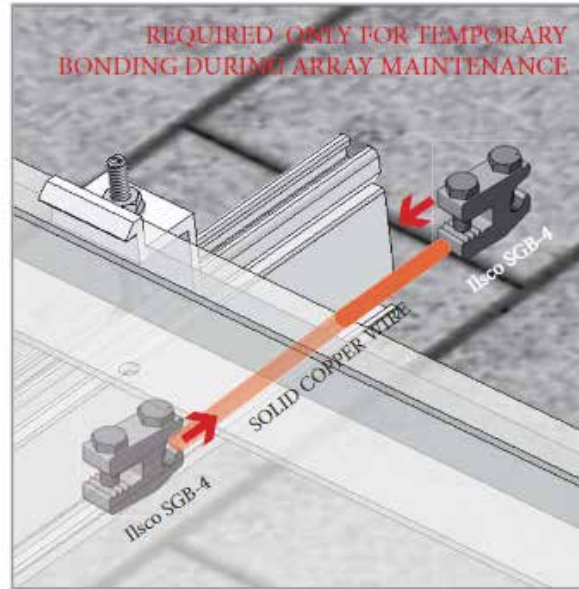

TEMPORARY BONDING CONNECTION DURING ARRAY MAINTENANCE

When removing modules for replacement or system maintenance, any module left in place that is secured with a bonding Midclamp will be properly grounded. If a module adjacent to the end module of a row is removed or if any other maintenance condition leaves a module without a bonding mid clamp, a temporary bonding connection must be installed as shown

- Attach Ilco SGB4 to wall of GFT rail(Rail shown in picture is not a GFT rail but a representative rail for demonstration only)
- Attach Ilco SGB4 to module frame
- Install solid #6 AWG copper wire jumper to Ilco lugs

NOTE: All Unirac mid clamps and the UAF end clamp shown in this install guide are bonding clamps

ELECTRICAL CONSIDERATIONS

GFT is intended to be used with PV modules that have a system voltage less than or equal to 1000 VDC. For standard system grounding a minimum 10AWG, 105°C copper grounding conductor should be used to ground a system, according to National Electric Code (NEC). according to the National Electric Code (NEC). It is the installer's responsibility to check local codes, which may vary. See below for interconnection information.

INTERCONNECTION INFORMATION

There is no size limit on how many GFT & PV modules can be mechanically interconnected for any given configuration, provided that the installation meets the requirements of applicable building and fire codes.

GROUNDING NOTES

The installation must be conducted in accordance with the National Electric Code (NEC) and the authority having jurisdiction. Please refer to these resources in your location for required grounding lug quantities specific to your project.

The grounding / bonding components may overhang parts of the array so care must be made when walking around the array to avoid damage.

Conductor fastener torque values depend on conductor size. See product data sheets for correct torque values.

Mid clamps do not need to be repositioned for re-use.

Electrical Bonding and Grounding Test Modules

The list below is not exhaustive of compliant modules but shows those that have been evaluated and found to be electrically compatible with the GROUND FIXED TILT system.

Manufacture	Module Model / Series	Manufacture	Module Model / Series	Manufacture	Module Model / Series
Aionrise	AION60G1, AION72G1			HT Solar (cont.)	HT60-156M-C HT60-156M(V)-C
Aleo	P-Series & S-Series			Hyundai	KG, MG, RW, TG, RI, RG, TI, KI, HI Series HiA-SxxxHG, HiD-SxxxRG(BK), HiS-S400PI
Aptos Solar	DNA-120-MF10 DNA-120-(MF/BF)23 DNA-144-(MF/BF)23 DNA-120-(MF/BF)26 DNA-144-(MF/BF)26	Canadian Solar (cont.)	CS5A-M CS6K-(M/MS/MS AllBlack/P/P HE) CS6P-(M/P) CS6U-(M/P/P HE) CS6X-P CSX-P ELPS CS6(A/P)-MM	ITEK	iT-SE Series
Astronergy	CHSM6612 M, M/HV CHSM6612P Series CHSM6612P/HV Series CHSM72M-HC CHSM72M(DG)/F-BH	Centrosolar America	C-Series & E-Series	Japan Solar	JPS-60 & JPS-72 Series
Auxin	AXN6M610T AXN6P610T AXN6M612T AXN6P612T	CertainTeed	CT2xxMxx-01, CT2xxPxx-01, CTxxxMxx-01 CTxxxPxx-01, CTxxxMxx-02, CTxxxMxx-03 CTxxxMxx-04, CTxxxHC11-04	JA Solar	JAM72D30 xxx/MB, JAM78D10 xxx/MB JAP6 60-xxx JAM6(k)-60/xxx, JAP6(k)-72-xxx/4BB JAP72S##-xxx/** JAP6(k)-60-xxx/4BB, JAP60S##-xxx/** JAM6(k)-72-xxx/**; JAM72S##-xxx/** JAM6(k)-60-xxx/**; JAM60S##-xxx/** i. ##: 01, 02, 03, 09, 10 ii. **: SC, PR, BP, HiT, IB, MW, MR ** = Backsheet, ## Cell technology
Axitec	AC-xxx(M/P)/60S, AC-xxx(M/P)/72S AC-xxxP/156-60S AC-xxxMH/120(S/V/SB/VB) AC-xxxMH/144(S/V/SB/VB)	Eco Solargy	Orion 1000 & Apollo 1000	Jinko	JKM & JKMS Series JKMxxxM-72HL-V JKMxxxM-72HL4-(T)V JKMxxxM-7RL3-V
Boviet	BVM6610, BVM6612	ET Solar	ET AC Module, ET Module	Kyocera	KD-F & KU Series
BYD	P6K & MHK-36 Series	First Solar	FS-6XXX(A) FS-6XXX(A)-P, FS-6XXX(A)-P-I	LA Solar	LSxxxHC(166)
Canadian Solar	CS1(H/K/U/Y)-MS CS3K-(MB/MB-AG/MS/P/P HE/PB-AG) CS3L-(MS/P) CS3N-MS CS3U-(MB/MB-AG/MS/P/P HE/PB/PB-AG) CS3W-(MS/P/P-PB-AG)	Flextronics	FXS-xxxBB	LG Electronics	LGxxx(E1C/E1K/N1C/N1K/N2T/N2W/S1C/ S2W/Q1C/Q1K)-A5 LGxxx(A1C/M1C/M1K/N1C/N1K/Q1C/Q1K/ QAC/QAK)-A6 LGxxxN2W-B3
		FreeVolt	PVGraf		
		GCL	GCL-P6 & GCL-M6 Series		
		Hanwha SolarOne	HSL 60		
		Hansol	TD-AN3, TD-AN4 UB-AN1, UD-AN1		
		Heliene	36M, 36P 60M, 60P, 72M & 72P Series 144HC M6		
		HT Solar	HT72-156(M/P) HT72-156P-C, HT72-156P(V)-C HT72-156M(PDV)-BF, HT72-156M(PD)-BF		

The modules selected for UL 2703 bonding and grounding testing represent the broadest possible range of modules on the market. The tests were performed for each specific bonding location using representative module frame profile sections. The tests performed cover the following basic module parameters:

- The frame profile must not have any feature that might interfere with the bonding devices that are integrated into the racking system
- Use with a maximum over current protection device OCPD of 30A
- Unless otherwise noted, all modules listed above include all wattages and specific models within that series. Variable wattages are represented as "xxx"
- Items in parenthesis are those that may or may not be present in a compatible module's model ID
- Slashes "/" between one or more items indicates that either of those items may be the one that is present in a module's model ID

Electrical Bonding and Grounding Test Modules

The list below is not exhaustive of compliant modules but shows those that have been evaluated and found to be electrically compatible with the GROUND FIXED TILT system.

Manufacture	Module Model / Series	Manufacture	Module Model / Series	Manufacture	Module Model / Series	
LG Electronics (cont.)	LGxxxN2T-B5	Peimar	SGxxxM (FB/BF)	Q_Cells (cont.)	Q.PEAK DUO BLK G10+ /AC	
	LGxxxN1K-B6		SMxxxM		Q.PEAK DUO (BLK) ML-G10(a)(+)	
	LGxxx(N1C/N1K/N2T/N2W)-E6	Phono Solar	PSxxxM1-20/U		Q.PEAK DUO XL-(G10/G10.2/G10.3/G10.c/G10.d)	
	LGxxx(N1C/N1K/N2W/S1C/S2W)-G4		PSxxxM1H-20/U		Q.PEAK DUO XL-G10.3/BFG	
	LGxxxN2T-J5		PSxxxM1-20UH		Q.PEAK DUO XL-G10.d/BFG	
	LGxxx(N1K/N1W/N2T/N2W)-L5		PSxxxM1H-20UH		Q.PEAK DUO XL-(G11.2/G11.3)	
	LGxxx(M1C/N1C/Q1C/Q1K)-N5		PSxxxM1-20/UH		Q.PEAK DUO XL-G11.3/BFG	
	LGxxx(N1C/N1K/N2W/Q1C/Q1K)-V5		PSxxxM1H-20/UH			
	LGxxxN3K-V6		PSxxxM-24/T			
			PSxxxMH-24/T			
	PSxxxM-24/TH					
	PSxxxMH-24/TH					
LONGi	LR4-60(HPB/HPH)	Prism Solar	P72 Series	REC	RECxxxAA (BLK/Pure)	
	LR4-72(HBD/HPH)				RECxxxNP (N-PEAK)	
	LR6-60	Q_Cells	Plus, Pro, Peak, G3, G4, Peak G5(SC) , G6(+)(SC)(AC), G7, G8(+) Plus, Pro, Peak L-G2, L-G4, L-G5 Peak L-G5, L-G6, L-G7, L-G8(BFF) Q.PEAK DUO(BLK)-G6+ Q.PEAK DUO BLK-G6+/TS Q.PEAK DUO (BLK)-G7 Q.PEAK DUO L-(G7/G7.1/G7.2/G7.3/G7.7) Q.PEAK DUO (BLK) G8(+) Q.PEAK DUO L-(G8/G8.1/G8.2/G8.3) Q.PEAK DUO L-G8.3 BFG/BGT Q.PEAK DUO (BLK) ML-G9(+) Q.PEAK DUO XL-(G9/G9.2/G9.3) Q.PEAK DUO XL-G9.3 BFG Q.PEAK DUO G10+ Q.PEAK DUO BLK G10(+)		RECxxxNP2 (Black)	
	LR6-60(BK/HPB/HPH/HV/PB/PE/PH)					RECxxxPE, RECxxxPE72
	LR6-72					RECxxxTP, RECxxxTP72
LR6-72(BK/HBD/HV/PB/PE/PH)		RECxxxTP2(M/BLK2)				
RealBlack LR4-60HPB		RECxxxTP2S(M)72				
RealBlack LR6-60HPB		RECxxxTP3M (Black)				
				RECxxxTP4 (Black)		
Meyer Burger	Meyer Burger Black, Meyer Burger White				Renesola	All 60-cell modules
Mission Solar Energy	MSE Mono, MSE Perc				Risen	RSM Series
Mitsubishi	MJE & MLE Series				S-Energy	SN72 & SN60 Series
Neo Solar Power Co.	D6M Series			SEG Solar	SEG-xxx-BMD-HV	
Panasonic	VBHNxxxSA06/SA06B/SA11/SA11B			Seraphim	SEG-(6PA/6PB/6MA/6MA-HV/6MB/E01/E11)	
	VBHNxxxSA15/SA15B/SA16/SA16B,				SRP-(6QA/6QB)	
	VBHNxxxKA, VBHNxxxKA03/04,				SRP-xxx-6MB-HV, SRP-320-375-BMB-HV,	
	VBHNxxxSA17/SA17G/SA17E/SA18/SA18E,				SRP-xxx-BMC-HV, SRP-390-450-BMA-HV,	
	VBHNxxxZA01/ZA02/ZA03/VBHNxxxZA04,				SRP-xxx-BMZ-HV, SRP-390-405-BMD-HV	
EVPVxxx				Sharp	NU-SA & NU-SC Series	
EVPVxxx(H/K/PK)						

The modules selected for UL 2703 bonding and grounding testing represent the broadest possible range of modules on the market. The tests were performed for each specific bonding location using representative module frame profile sections. The tests performed cover the following basic module parameters:

- The frame profile must not have any feature that might interfere with the bonding devices that are integrated into the racking system
- Use with a maximum over current protection device OCPD of 30A
- Unless otherwise noted, all modules listed above include all wattages and specific models within that series. Variable wattages are represented as "xxx"
- Items in parenthesis are those that may or may not be present in a compatible module's model ID
- Slashes "/" between one or more items indicates that either of those items may be the one that is present in a module's model ID

Electrical Bonding and Grounding Test Modules

The list below is not exhaustive of compliant modules but shows those that have been evaluated and found to be electrically compatible with the GROUND FIXED TILT system.

Manufacture	Module Model / Series	Manufacture	Module Model / Series
Silfab	SLA-M, SLA-P, SLG-M, SLG-P & BC Series SILxxx(BL/NL/NT/HL/ML/BK/NX/NU/HC)	URECO	D7Kxxx(H7A/H8A), D7Mxxx(H7A/H8A) FAKxxx(C8G/E8G), FAMxxxE7G-BB FAMxxxE8G(-BB), FBKxxxM8G
Solaria	PowerXT-xxxR-(AC/PD/BD) PowerXT-xxxC-PD PowerXT-xxxR-PM (AC)	Vikram	Eldora, Somera, Ultima PREXOS VSM DHT.60.AAA.05 PREXOS VSM DHT.72.AAA.05
Solartech	STU HJT, STU PERC & Quantum PERC	Vina	VNS-72M1-5-xxxW-1.5 VNS-72M3-5-xxxW-1.5 VNS-144M1-5-xxxW-1.5 VNS-144M3-5-xxxW-1.5 VNS-120M3-5-xxxW-1.0
SolarWorld	Sunmodule Protect, Sunmodule Plus/Pro	VSUN	VSUNxxx-60M-BB, VSUNxxx-72MH VSUN4xx-144BMH
Suniva	MV Series & Optimus Series (35mm)	Winaico	WST & WSP Series
SunPower	AC, X-Series, E-Series & P-Series SPR E20 435 COM (G4 Frame) Axxx-BLK-G-AC, SPR-Mxxx-H-AC	Yingli	YGE & YLM Series
Suntech	STP, STPXXXS - B60/Wnhb	ZNShine Solar	ZXM6-72 Series ZXM6-NH144 ZXM6-NHLDD144
Sun Edison	F-Series, R-Series		
Talesun	TP572, TP596, TP654, TP660 TP672, Hipor M, Smart		
Tesla	SC, SC B, SC B1, SC B2, TxxxS, TxxxH		
Trina	PA05, PD05, DD05, DD06, DE06, DE09.05 PD14, PE14, DD14, DE14, DE15, DE15V(II) DEG15HC.20(II), DEG15MC.20(II) DEG15VC.20(II), DE18M(II), DEG18MC.20(II) DE19, DEG19C.20		
TSMC	TS-150C2 CIGSw		
Upsolar	UP-MxxxP, UP-MxxxM(-B)		

The modules selected for UL 2703 bonding and grounding testing represent the broadest possible range of modules on the market. The tests were performed for each specific bonding location using representative module frame profile sections. The tests performed cover the following basic module parameters:

- The frame profile must not have any feature that might interfere with the bonding devices that are integrated into the racking system
- Use with a maximum over current protection device OCPD of 30A
- Unless otherwise noted, all modules listed above include all wattages and specific models within that series. Variable wattages are represented as "xxx"
- Items in parenthesis are those that may or may not be present in a compatible module's model ID
- Slashes "/" between one or more items indicates that either of those items may be the one that is present in a module's model ID

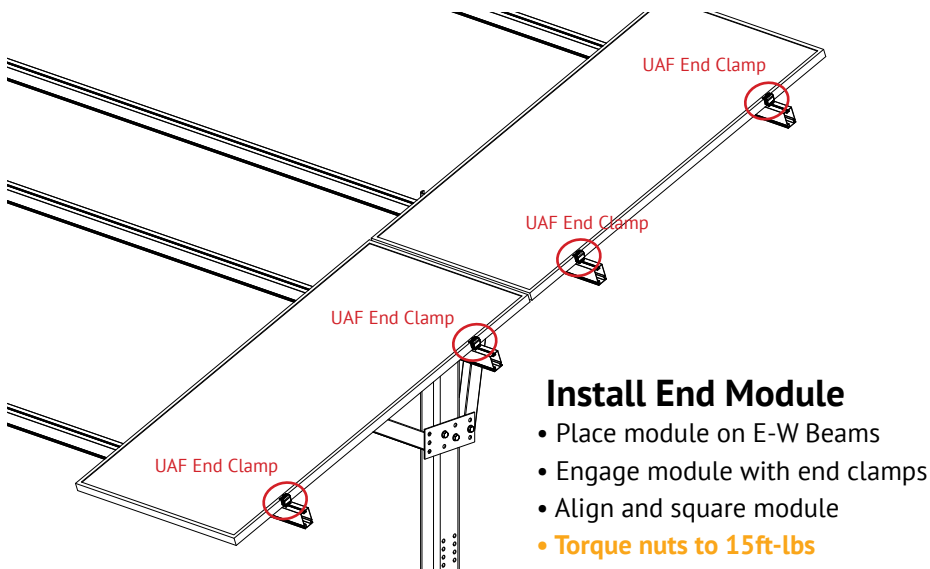
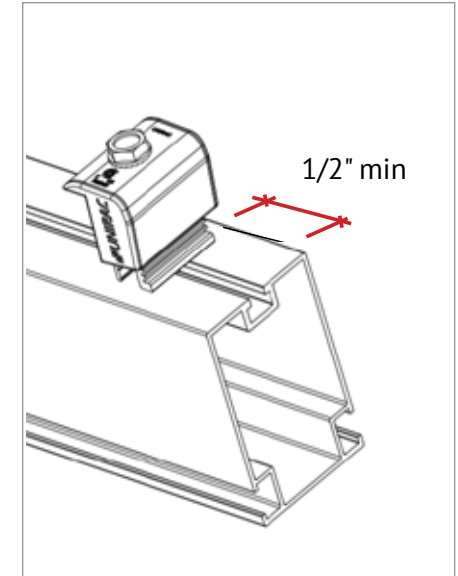
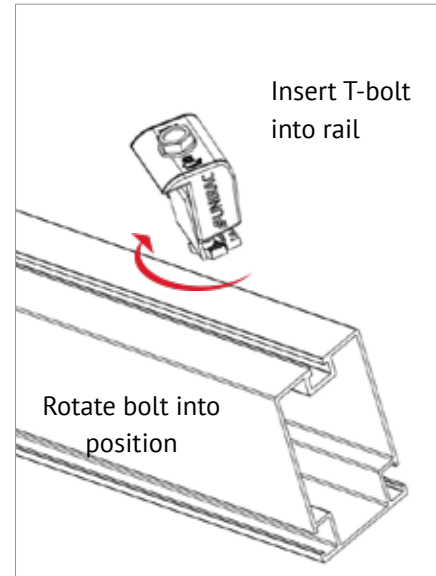
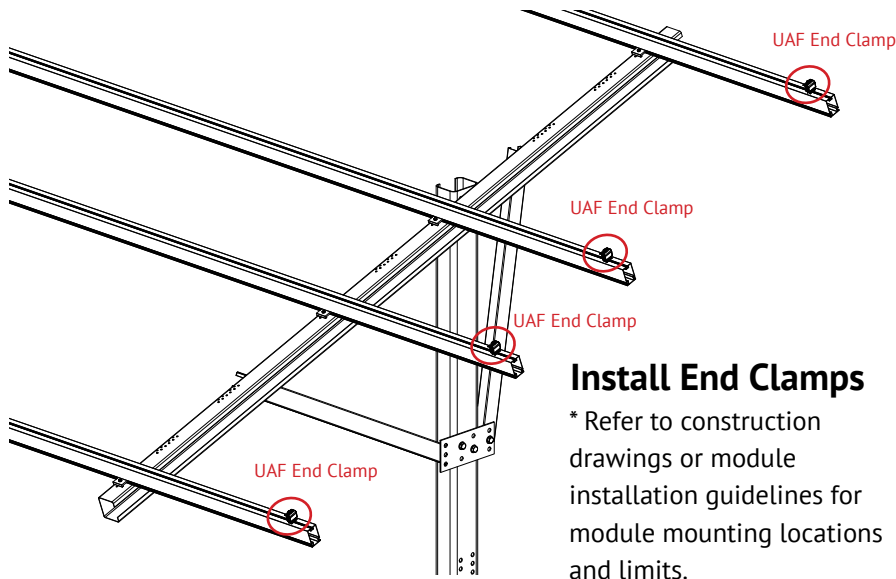

Serrated T- Bolts

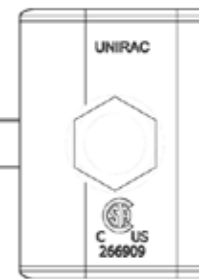

Verify that bolt position indicator is perpendicular to E-W beam

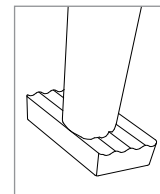

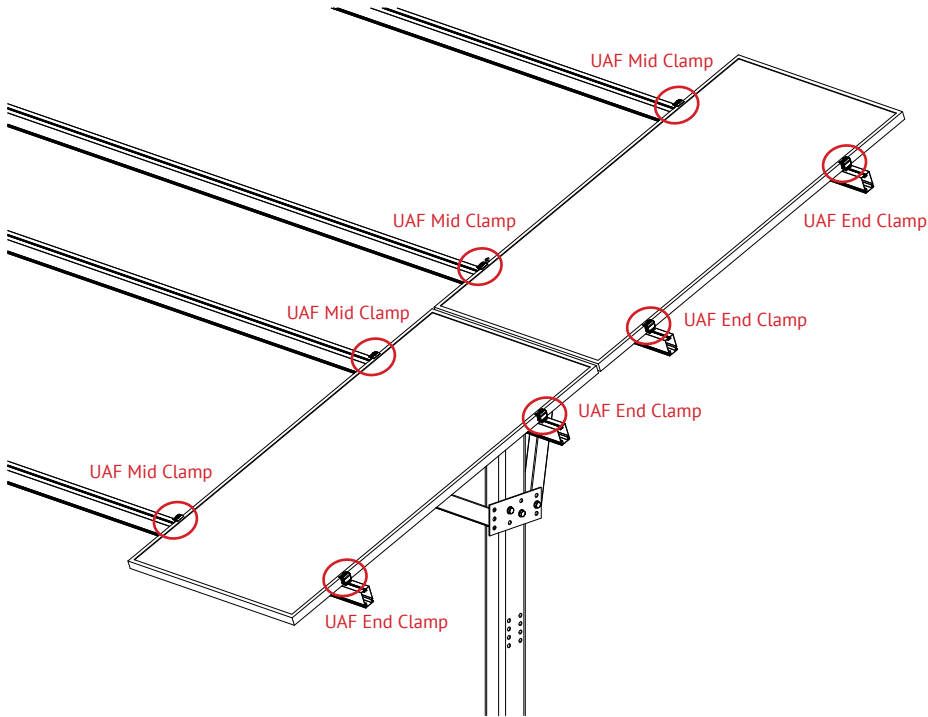

Install Mid Clamps

(Position upright against module but do not torque.) When ready - **torque to 15ft-lbs.**

NOTE: Please refer to the GFT Shared rail install manual when using a shared rail.

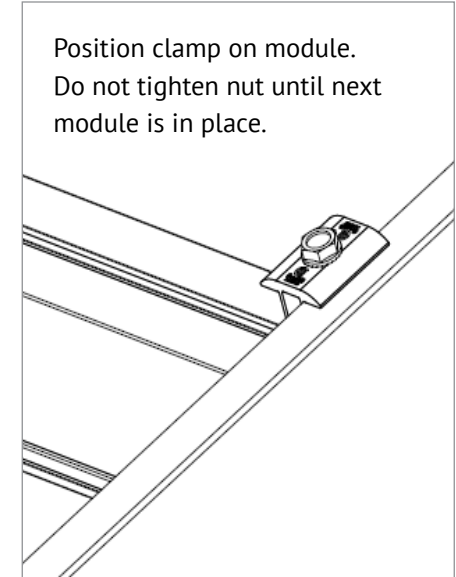
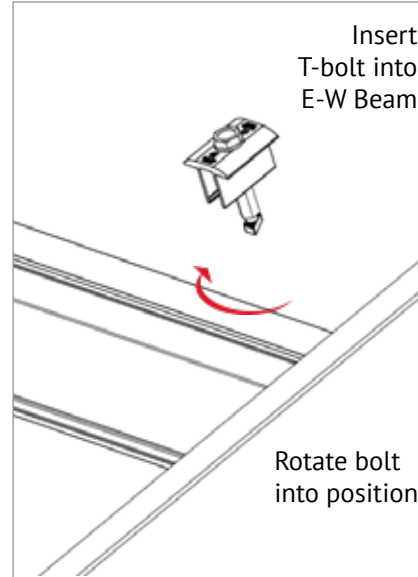

Serrated T- Bolts

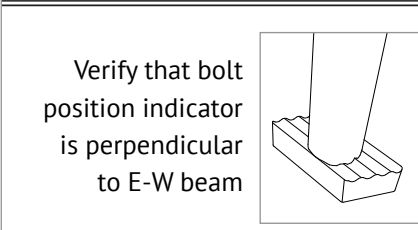
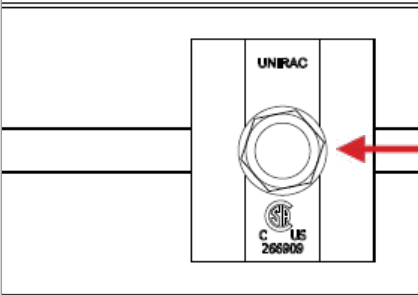

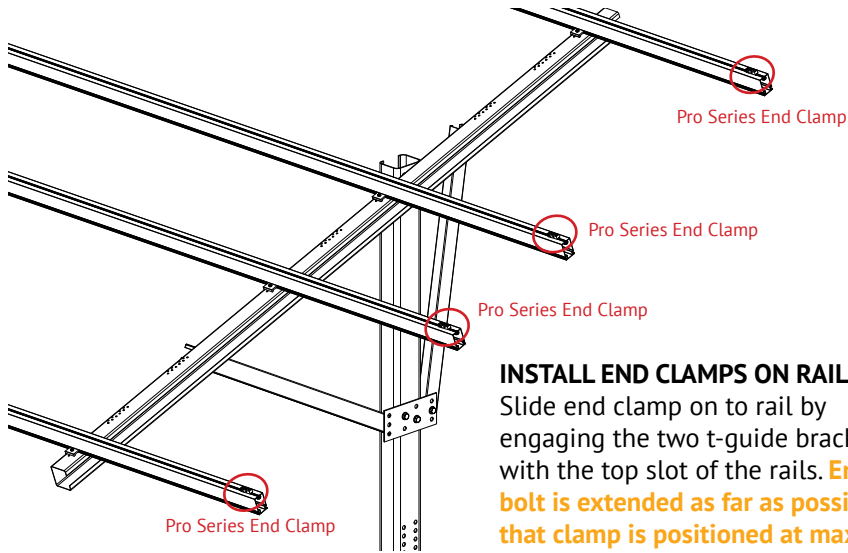

INSTALL END CLAMPS ON RAIL:
Slide end clamp on to rail by engaging the two t-guide brackets with the top slot of the rails. **Ensure bolt is extended as far as possible so that clamp is positioned at max. distance from end of rail.**

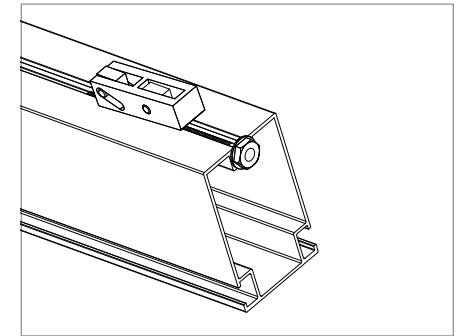
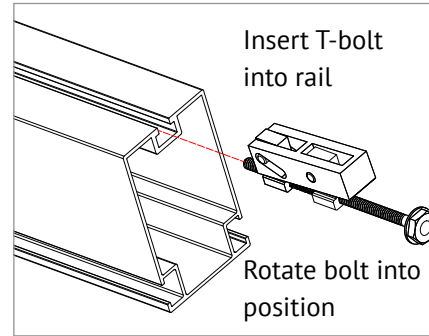

POSITION END CLAMPS:
Slide end clamp assembly on to rail until bolt head engages with end of rail. **End clamps are positioned on rails prior to the first end module and prior to the last end module.**

NOTE:
To assist insertion of clamp into rail slot, Pressure may be applied to top or side of bracket as shown. Do not force clamp into rail by pushing on bolt with excessive force.

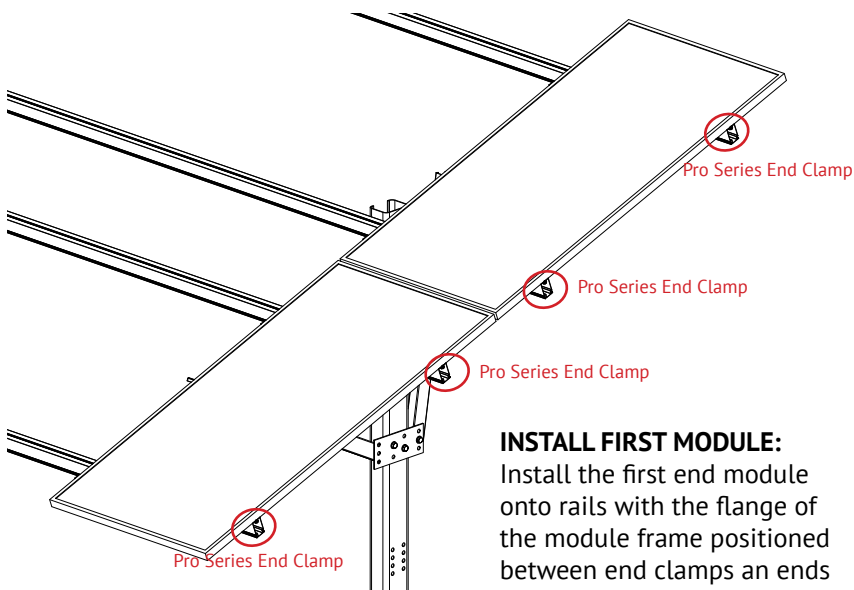

INSTALL FIRST MODULE:
Install the first end module onto rails with the flange of the module frame positioned between end clamps and ends of rails.

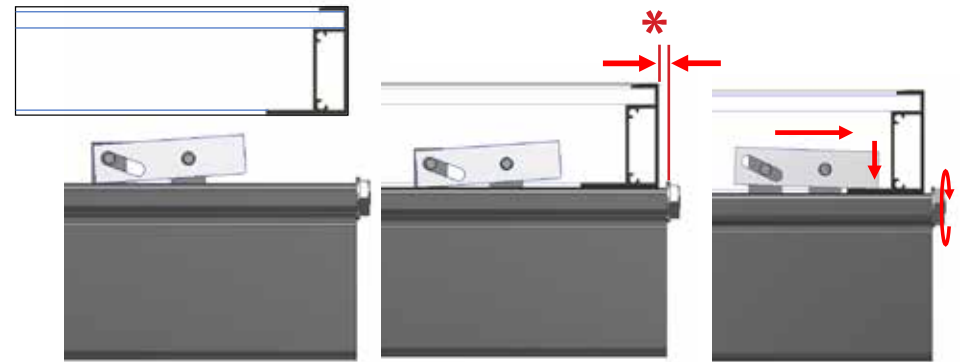

ENGAGE CLAMP:
While holding module in position and with flange in full contact with rail, rotate end clamp bolt until clamp engages with flange to provide clamp force. **To ensure bolt is not over-torqued, use low torque setting on drill or If using an impact driver, stop rotation as soon as impact action of driver begins. TORQUE VALUE (See table and notes on PG. 1) End clamp bolt to 5 ft-lbs, No anti-seize**

***** Position module flush with ends of rails. Rails should not extend more than 1/2" beyond module. Module must be fully supported by rails and cannot overhang ends of rails.

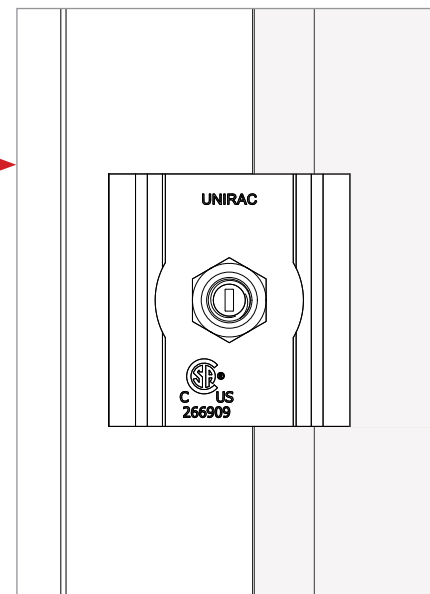
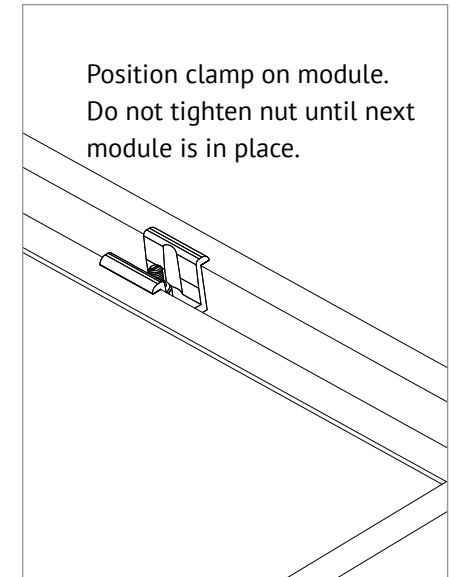
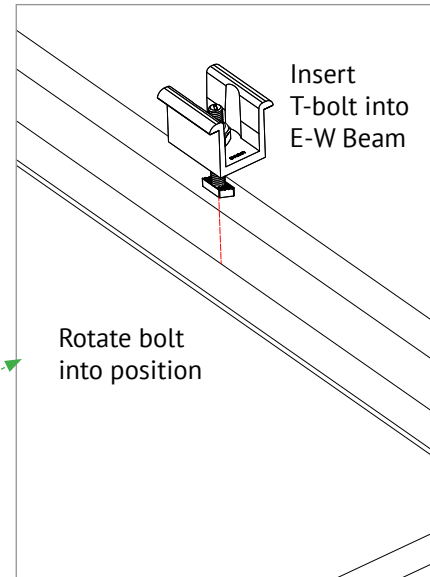
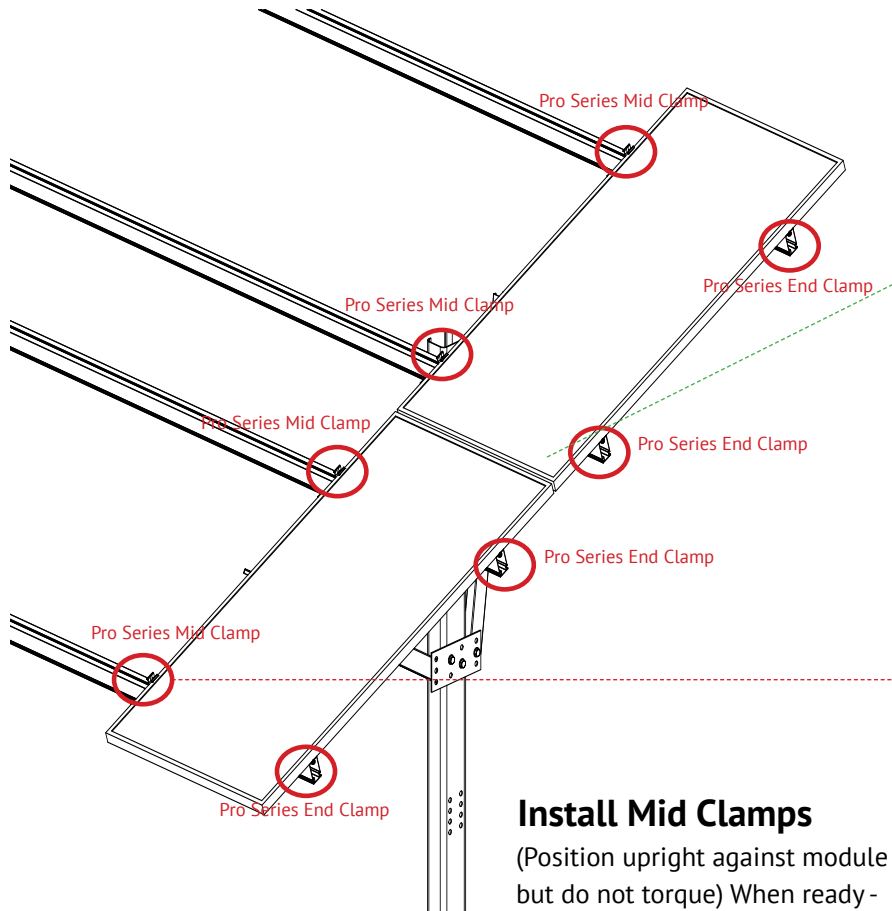

Verify that bolt position
indicator is perpendicular
to E-W beam once nut is
torqued

GENERAL NOTES:

- ALL CONSTRUCTION FOR UNIRAC'S "GROUND FIXED TILT" (GFT) RACKING SYSTEM AND FOUNDATION REQUIREMENTS SHALL CONFORM TO THE 2009, 2012, 2015 & 2018 EDITION OF THE INTERNATIONAL BUILDING CODE (IBC).
- WHEREVER THE TERM CONTRACTOR IS USED IN THE CONSTRUCTION DOCUMENTS, IT SHALL BE DEFINED TO MEAN THE GENERAL CONTRACTOR AND ANY SUB-CONTRACTOR COLLECTIVELY AS APPLICABLE AND AS REQUIRED.
- THE CONTRACT "STRUCTURAL RACKING" DRAWINGS REPRESENT THE FINISHED STRUCTURE. THEY DO NOT INDICATE THE MEANS, METHOD, OR SEQUENCE OF CONSTRUCTION. THE CONTRACTOR SHALL BE RESPONSIBLE FOR AND PROVIDE ALL MEASURES NECESSARY TO PROTECT THE RACKING SYSTEM FROM THE POINT OF MATERIAL DELIVERY THROUGH THE COMPLETION OF CONSTRUCTION. UNIRAC AND THE ENGINEER OF RECORD WILL NOT BE RESPONSIBLE FOR THE CONTRACTOR'S MEANS, METHODS, TECHNIQUES, SEQUENCES OR PROCEDURES OF CONSTRUCTION. UNIRAC AND THE ENGINEER OF RECORD WILL NOT BE RESPONSIBLE FOR CONSTRUCTION SITE SAFETY, OR SAFETY PRECAUTIONS AND PROGRAMS INCIDENT HERETO.
- IT IS THE CONTRACTOR'S RESPONSIBILITY TO INSPECT AND ENSURE THAT ALL WORK IS IN CONFORMANCE WITH THE CONTRACT DOCUMENTS. ANY STRUCTURAL INSPECTION/OBSERVATION PROVIDED BY OTHERS DOES NOT RELIEVE THE CONTRACTOR OF THIS RESPONSIBILITY.
- ANY DEVIATIONS FROM THE CONTRACT DOCUMENTS THAT ARE ENCOUNTERED AT A LATER DATE AND ARE DECLARED TO BE SIGNIFICANT BY THE RACKING DISTRIBUTOR SHALL BE CORRECTED BY THE CONTRACTOR (AT THE CONTRACTOR'S EXPENSE).
- CONTRACTOR SHALL VERIFY ALL DIMENSIONS AND COORDINATE SITE CONDITIONS WITH THESE DRAWINGS PRIOR TO BIDDING OR THE START OF CONSTRUCTION. ANY CONFLICTS, DISCREPANCIES, OR OMISSIONS SHALL BE RESOLVED THROUGH YOUR RACKING DISTRIBUTOR PRIOR TO PROCEEDING.
- DO NOT SCALE OFF OF THESE DRAWINGS. WRITTEN DIMENSIONS SHALL BE USED OR WHERE NO DIMENSION IS PROVIDED CONSULT WITH YOUR RACKING DISTRIBUTOR FOR CLARIFICATION BEFORE PROCEEDING WITH THE BID OR THE WORK.
- IT IS THE CONTRACTOR'S RESPONSIBILITY TO ENSURE THAT THE EQUIPMENT AND INSTALLATION PROCESS (MEANS AND METHODS) ARE APPROPRIATE FOR THE FOUNDATIONS AND THAT THE PILES ARE INSTALLED TO THE SPECIFIED TOLERANCES. UNIRAC IS NOT RESPONSIBLE FOR DAMAGED AND/OR OUT-OF-TOLERANCE PILES DUE TO IMPROPER INSTALLATION EQUIPMENT, METHODS, AND SOIL RELATED ISSUES INCLUDING DENSE SOILS, GRAVEL, OR BEDROCK.
- WHERE ANY DISCREPANCIES OCCUR BETWEEN PLANS, DETAILS, STRUCTURAL NOTES AND SPECIFICATIONS, THE GREATER (MOST CONSERVATIVE) REQUIREMENTS SHALL GOVERN. WHERE NO SPECIFIC DETAIL IS SHOWN, CONSTRUCTION SHALL CONFORM TO SIMILAR WORK ON THE PROJECT, OR IF THERE IS NO SIMILAR WORK, THEN CONSTRUCTION SHALL CONFORM TO INDUSTRY STANDARDS. CONTRACTOR MUST INFORM UNIRAC OF ANY DISCREPANCIES.
- REFER TO SITE PLAN, PILE LAYOUT DRAWING, ELECTRICAL DRAWINGS AND/OR OTHER CIVIL DRAWINGS FOR SPECIFIC PILE LOCATIONS, NORTH-SOUTH PILE SPACING, LOCATION AND DETAILS OF CURBS, INVERTER/EQUIPMENT PADS, TRENCHING/CONDUIT LOCATIONS, JUNCTION BOXES, SITE WORK ITEMS, ETC. AND DIMENSIONS NOT SHOWN ON STRUCTURAL RACKING DRAWINGS.
- CONTRACTOR SHALL INVESTIGATE THE SITE DURING CLEARING AND EARTHWORK OPERATIONS FOR FILLED EXCAVATIONS OR BURIED STRUCTURES, SUCH AS CESSPOOLS, CISTERNS, EXISTING FOUNDATIONS, OR OTHER.
- ASTM SPECIFICATIONS ON THE DRAWINGS SHALL BE OF THE LATEST ASTM STANDARD SPECIFICATION.
- ANY ENGINEERING DESIGN PROVIDED BY OTHERS AND SUBMITTED FOR REVIEW SHALL BEAR THE SEAL OF A PROFESSIONAL CIVIL OR STRUCTURAL ENGINEER REGISTERED IN THE STATE OF THE LOCAL JURISDICTION.
- THE FOLLOWING DESIGN CRITERIA IS EXCLUDED FROM THE RACKING AND FOUNDATION DESIGN: FLOOD LOADING, DEBRIS LOADING, DYNAMIC ANALYSIS, ACTS OF GOD (TORNADO, HURRICANE, WATER INUNDATION LOADING, ETC.), EROSION, EXPANSIVE SOILS, FROST HEAVE, SOIL LIQUEFACTION, DYNAMIC LOADING FROM SEISMIC EVENTS AND CONDITIONS. THE DESIGN CAN CONSIDER THIS CRITERIA FOR SPECIFIC PROJECTS IN A SEPARATE DOCUMENT FROM UNIRAC OR BY A THIRD PARTY ENGINEER.
- DESIGN CRITERIA PER ASCE 7-05, 7-10, OR ASCE 7-16:
 - DESIGN WIND SPEED = VARIES (SEE DESIGN PACKAGE AND STATE LETTER)
 - GROUND SNOW LOAD = VARIES (SEE DESIGN PACKAGE AND STATE LETTER)
 - ICE THICKNESS = VARIES (SEE DESIGN PACKAGE AND STATE LETTER)
 - ICE LOAD WIND SPEED = VARIES (SEE DESIGN PACKAGE AND STATE LETTER)
 - SEISMIC Ss = VARIES (SEE DESIGN PACKAGE AND STATE LETTER)
 - SEISMIC S1 = VARIES (SEE DESIGN PACKAGE AND STATE LETTER)
 - SOIL SITE CLASS = D
 - WIND EXPOSURE CATEGORY = B OR C (SEE LETTER)
 - HURRICANE ZONE = SEE LETTER
 - RISK CATEGORY = I OR II (SEE LETTER)
 - MINIMUM OF 20' OFFSET FROM NEAREST ADJACENT BUILDING (TO AVOID SNOW DRIFT.)
- "DESIGN WIND PRESSURES PER ASCE 7-05, SECTION 6.5.13, "WIND LOADS ON OPEN BUILDINGS WITH MONOSLOPE, PITCHED OR TROUGHED ROOFS", AND SECTION 6.5.13.3, "COMPONENTS AND CLADDING" FOR MONOSLOPE FREE ROOFS, ASCE 7-10, SECTION 27.4.3, "WIND LOAD ON OPEN BUILDING WITH MONOSLOPE, PITCHED OR TROUGHED FREE ROOFS", AND SECTION 30.7.1, "COMPONENTS AND CLADDING" FOR MONOSLOPE PITCHED OR TROUGHED ROOFS, OR ASCE 7-16, SECTION 27.3.2, "WIND LOAD ON OPEN BUILDING WITH MONOSLOPE, PITCHED OR TROUGHED ROOFS", AND SECTION 30.7.2, "COMPONENTS AND CLADDING" FOR MONOSLOPE, PITCHED OR TROUGHED ROOFS.
- SOLAR REQUIREMENTS: FROM OWNER
- CORROSION PROTECTION REQUIREMENTS:
 - COLD-FORMED STEEL MEMBERS = SEE MEMBER SECTION TABLE
 - HARDWARE = STAINLESS STEEL OR DELTA PROTEKT
- ABOVE GRADE CORROSION PROTECTION WILL SUFFICE FOR MOST ENVIRONMENTAL CONDITIONS. BELOW GRADE CORROSION PROTECTION WILL SUFFICE FOR MOST SOILS WITH RESISTIVITY VALUES GREATER THAN 10,000 OHM/CM. IT IS THE OWNER'S RESPONSIBILITY TO DETERMINE IF THE SOILS ARE MORE CORROSIVE AND FURTHER CORROSION PROTECTION WILL BE REQUIRED.
- IT IS THE CONTRACTOR'S RESPONSIBILITY TO SPICE EAST-WEST BEAMS (AS REQUIRED) TO COMPLETE THE TABLE AND AVOID SPLICE CONFLICTS SPECIFIED IN DETAIL 502 ON SHEET SR-500.
- EACH ROW CANNOT EXCEED 100 FEET IN LENGTH WITHOUT HAVING A THERMAL BREAK.

SPECIAL INSPECTION (PER CHAPTER 17 OF THE IBC):

- STRUCTURAL ONLY: SPECIAL INSPECTION IS TO BE PROVIDED FOR THE ITEMS LISTED BELOW IN ADDITION TO THE INSPECTIONS CONDUCTED BY THE BUILDING JURISDICTION. "SPECIAL STRUCTURAL INSPECTION" SHALL NOT RELIEVE THE OWNER OR THEIR AGENT FROM REQUESTING THE BUILDING JURISDICTION INSPECTIONS REQUIRED.
- DRIVEN DEEP ELEMENTS: PERIODICALLY DURING THE PLACEMENT OF ALL DRIVEN DEEP FOUNDATION ELEMENTS ON STRUCTURAL DRAWINGS.
 - VERIFICATION OF ELEMENT MATERIALS, SIZES AND LENGTHS.
 - OBSERVATION AND DOCUMENTATION OF DRIVING OPERATIONS. MAINTAIN A COMPLETE AND ACCURATE RECORD FOR EACH PILE DRIVEN.
 - VERIFICATION OF PLACEMENT LOCATIONS AND PLUMBNESS, TYPE OF PILE DRIVER, ELEVATION OF TIP AND BUTT, ANY DAMAGE TO FOUNDATION ELEMENT, ETC.

2. BOLTING: VERIFICATION OF TORQUE PER TORQUE TABLE SHOWN.

TORQUE REQUIREMENTS:		
1/4"Ø HARDWARE :		SOCKET SIZE
BEAM CLAMP	= 9 - 11 FT-LBS	9/16"
STANDARD MID 7 END CLAMPS	= 9 - 11 FT-LBS	9/16"
PRO-SERIES MID-CLAMPS	= 10 - 12 FT-LBS	1/2"
PRO-SERIES END CLAMP	= 3 FT-LBS	1/2"
5/8"Ø HARDWARE	= 54 - 66 FT-LBS	15/16"
3/4"Ø HARDWARE	= 99 - 121 FT-LBS	1-1/8"

3. CONCRETE: SEE CHAPTER 17 OF MOST CURRENT IBC FOR REQUIRED INSPECTIONS.

ALUMINUM:

- ALL ALUMINUM EAST-WEST BEAM MEMBERS HAVE BEEN DESIGNED IN ACCORDANCE WITH THE "ALUMINUM DESIGN MANUAL" BY THE ALUMINUM DESIGN ASSOCIATION, CURRENT ADDITION.
- ALL ALUMINUM EAST-WEST BEAMS CONFORM TO ONE OF THE FOLLOWING:
 - ALLOY: 6005A TEMPER: T61 (F_{tu} = 38 KSI, F_{cy} = 35 KSI)
 - ALLOY: 6351 TEMPER: T5 (F_{tu} = 38 KSI, F_{cy} = 35 KSI)
 - ALLOY: 6061 TEMPER: T6 (F_{tu} = 38 KSI, F_{cy} = 35 KSI)
- ALL ALUMINUM EAST-WEST BEAMS HAVE A MILL FINISH.
- WELDING IS NOT REQUIRED OR PERMITTED UNLESS SPECIFICALLY APPROVED BY UNIRAC AND THE ENGINEER OF RECORD.
- FIELD CUTTING OF ALUMINUM MEMBERS IS PERMITTED WHEN REQUIRED TO ACCOMMODATE PROJECT SPECIFIC MODULE WIDTHS.

HARDWARE:

- ALL 1/4"Ø HARDWARE SHALL CONFORM TO 18/8 STAINLESS STEEL (AISI 300 SERIES STAINLESS, 304) OF DIMENSIONS PER ASME B18.2.1.
- ALL 1/4"Ø SELF DRILLING SCREW HARDWARE SHALL CONFORM TO GRADE 5 SAE J429 AND ASTM A449.
- ALL 5/8"Ø AND 3/4"Ø BOLTS SHALL CONFORM TO GRADE 2 SAE J429 OR ASTM A307.
- ALL 5/8"Ø AND 3/4"Ø SERRATED FLANGE NUTS SHALL CONFORM TO ASME B.18.16.4.
- ALL 5/8"Ø AND 3/4"Ø WASHERS SHALL CONFORM TO USS TYPE A WIDE OR ANSI TYPE A WIDE.
- UNIRAC T-BOLTS, MID CLAMPS, AND END CLAMPS ARE PROPRIETARY. TECHNICAL DATA SHEETS WITH TESTED CAPACITIES CAN BE PROVIDED UPON REQUEST.
- CORROSION PROTECTION FOR HARDWARE CAN BE FOUND IN THE GENERAL NOTES SECTION OF THIS DOCUMENT, NOTE 17.
- ALL HARDWARE RECEIVED ON SITE SHALL BE CHECKED BY CONTRACTOR AGAINST THE SPECIFICATIONS ON THIS SHEET SR-100, DIAMETERS AND LENGTHS CALLED OUT ON RACKING DETAILS SHEET SR-500, AS WELL AS THE PROJECT BILL OF MATERIAL. ANY CONFLICTS, DISCREPANCIES, OR OMISSIONS MUST BE RESOLVED WITH THE RACKING DISTRIBUTOR AS SOON AS POSSIBLE AND PRIOR TO PROCEEDING.

SOLAR DESIGN:

UNIRAC IS NOT THE SOLAR DESIGN ENGINEER OF RECORD AND IS NOT RESPONSIBLE FOR ANY SOLAR DESIGN, OUTPUT EFFICIENCIES, SHADING, ROW SPACING, POWER PRODUCTION, ETC.

ELECTRICAL DESIGN:

UNIRAC IS NOT THE ELECTRICAL ENGINEER OF RECORD AND IS NOT RESPONSIBLE FOR THE ELECTRICAL DESIGN FOR THIS PROJECT. THE UNIRAC GFT RACKING SYSTEM IS CERTIFIED TO UL-2703 WHEN PROPERLY INSTALLED. SEE THE GFT INSTALLATION GUIDE FOR MORE DETAIL.

CIVIL/GRADING/SITE WORK:

UNIRAC IS NOT THE CIVIL ENGINEER OF RECORD FOR THIS PROJECT AND IS NOT RESPONSIBLE FOR ANY SITE GRADING, SURVEYING, TRENCHING, EARTHWORK, LAYOUT, SWPPP, SURFACE WATER MITIGATION, PERMITTING, OR EROSION CONTROL PLANS.

MATERIAL MANAGEMENT:

PRIOR TO INSTALLATION, ALL MATERIALS MUST BE STORED PROPERLY. MATERIALS REMAINING IN PLACE FOR MORE THAN ONE WEEK MUST BE IN OPEN AIR CONDITIONS (I.E. OFF THE GROUND). IF TARPS OR OTHER PROTECTIVE COVERS ARE USED, THE ENDS SHALL BE LEFT OPEN FOR VENTILATION. TIGHT FITTING COVERINGS ARE NOT RECOMMENDED AS MATERIAL COATING ARE NOT DESIGNED FOR THIS CONDITION. LONG GOODS STORED HORIZONTALLY FOR MORE THAN ONE WEEK SHOULD NOT REMAINED BUNDLED TO PREVENT ACCELERATED CORROSION. BLOCKING IS REQUIRED BENEATH THE LONG GOODS AT PROPER INTERVALS TO ENSURE THE PRODUCT IS OFF THE GROUND.

FOUNDATION NOTES:

- SEE THE "COLD FORMED STEEL" SECTION FOR STEEL AND GALVANIZATION REQUIREMENTS FOR FOUNDATIONS.
- UNIRAC SHALL NOT BE HELD LIABLE FOR ANY UTILITY LINES DAMAGED DURING FOUNDATION INSTALLATION. IT SHALL BE THE RESPONSIBILITIES OF OTHERS TO DETERMINE THE PLACEMENT OF EXISTING AND NEW UTILITY LINES.
- PILES ARE DESIGNED TO SOIL CONDITIONS STATED IN IBC. IT IS THE CLIENTS RESPONSIBILITY TO VERIFY SOILS MEET THE MINIMUM REQUIREMENTS. UNIRAC AND OR THE ENGINEER OF RECORD WILL NOT BE HELD RESPONSIBLE FOR FOUNDATIONS INSTALLED IN SOILS WITH LOWER CAPACITY OR FOR IMPROPER FOUNDATION INSTALLATION OR CHOICE.

NOTE: SEE GFT INSTALLATION GUIDE FOR SYSTEM ADJUSTMENTS AND TOLERANCES

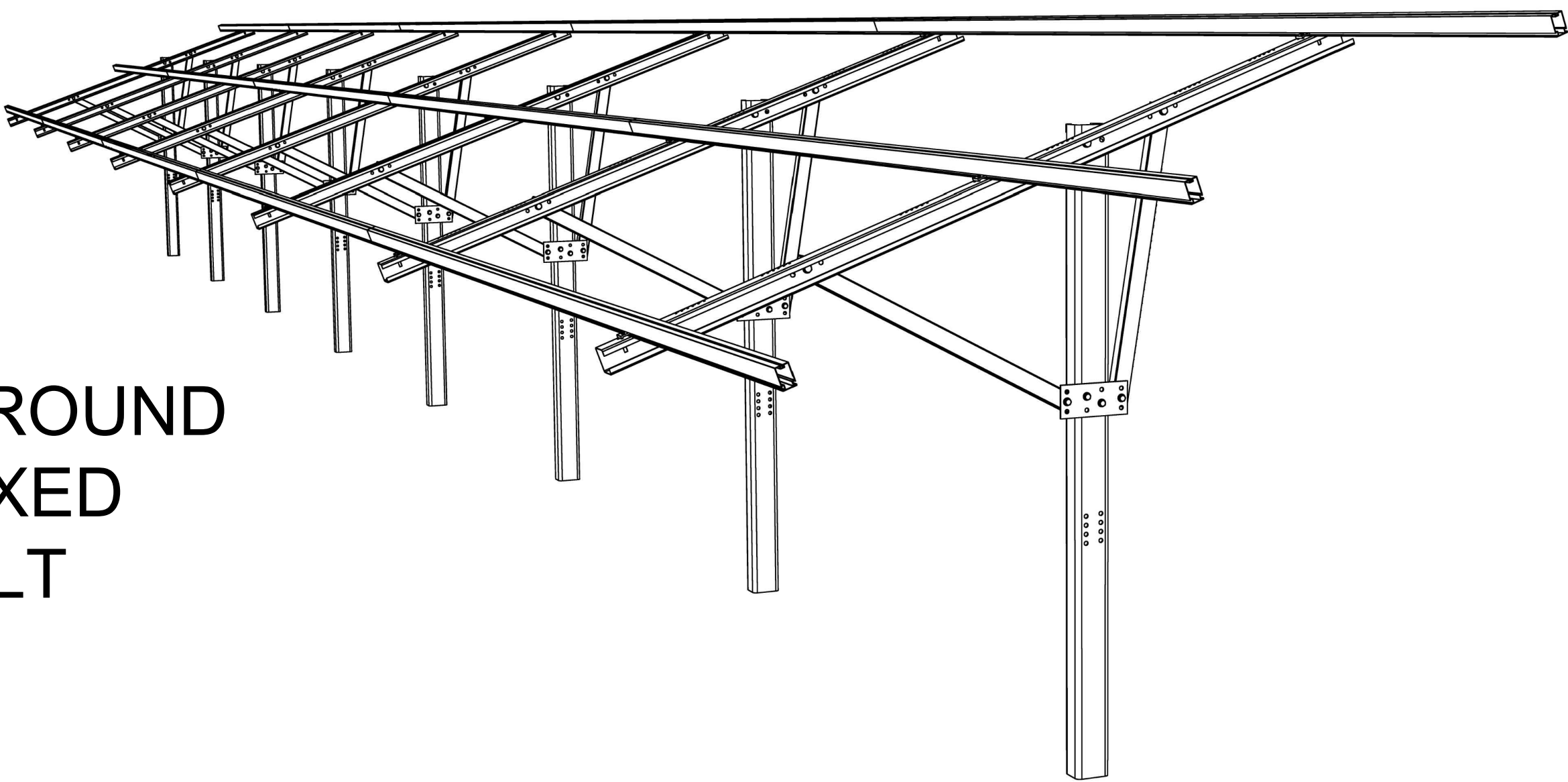

UNIRAC GROUND GFT FIXED TILT

COLD FORMED STEEL:

- ALL COLD FORMED STRUCTURAL STEEL MEMBER CONSTRUCTION SHALL BE IN ACCORDANCE WITH AISI "SPECIFICATIONS FOR DESIGN OF COLD-FORMED STEEL STRUCTURAL MEMBERS" CURRENT EDITION.
- ALL COLD-FORMED STRUCTURAL MEMBERS SHALL BE PER ICC-ER-4943P.
- ALL COLD-FORMED STEEL CONFORMS TO ONE OF THE FOLLOWING:
 - A653 HSLAS 50 (F_y = 50 KSI, F_u = 60 KSI)
 - A653 SS 50 CLASS 4 (F_y = 50 KSI, F_u = 60 KSI)
- ALL COLD-FORMED STEEL MEMBERS ARE GALVANIZED PER ASTM A653 (MOST RECENT EDITION).
- WELDING IS NOT REQUIRED OR PERMITTED UNLESS SPECIFICALLY APPROVED BY UNIRAC AND/OR THE ENGINEER OF RECORD.
- FIELD CUTTING OF COLD-FORMED STEEL MEMBERS IS NOT REQUIRED OR PERMITTED UNLESS THE C-PILE IS BEING MODIFIED DUE TO ALTERNATIVE FOUNDATION REQUIREMENTS PROVIDED ON SHEET 400.
- ALL CALCULATED COLD-FORMED MEMBER PROPERTIES PER AISI SPECIFICATIONS ARE BASED ON THE FOLLOWING MINIMUM THICKNESSES:
 - 14 GAGE (0.070" OR 70 MILS)
 - 11 GAGE (0.120" OR 120 MILS)

UNIRAC CUSTOM RACKING MEMBER SECTIONS				
RACKING MEMBER	DEPTH	WIDTH	THICKNESS	MIN. CORROSION PROTECT
ALUMINUM BEAM	3.25 IN.	2.0 IN.	0.063-0.125 IN	AAMA 611-12
ALUMINUM SPLICE	3.061 IN.	1.818 IN.	0.800-0.110 IN	AA-M12
TOP CHORD CHANNEL	4.1 IN.	3.42 IN.	14 GAGE	G180
DIAGONAL BRACE	3 IN.	2 IN.	14 GAGE	G180
C-PILE	6 IN.	4.5 IN.	11 GAGE	G235

DRIVEN STEEL PILE NOTES:

- STEEL PILES HAVE BEEN DESIGNED IN ACCORDANCE WITH THE DESIGN CRITERIA STATED IN THE GENERAL NOTES.
- PILES SHALL BE INSTALLED TO THE PILE TOLERANCES IN THE UNIRAC GFT INSTALLATION GUIDE WITHOUT EXCESSIVE DEFORMATION. EXCESSIVE DEFORMATION IS DEFINED AS DISTORTION PREVENTS THE RACKING FROM CONNECTING FLUSH TO THE PILE.
- FOUNDATIONS MUST NOT BE INSTALLED IN ORGANIC SOILS OR IN AREAS WITH GROUND WATER WITHIN 12 FEET OF THE SURFACE.
- IT IS THE OWNER OR CONTRACTORS RESPONSIBILITY TO DETERMINE WHICH FROST ZONE THEIR PROJECT IS LOCATED IN.
- IF PILE REFUSAL IS ENCOUNTERED, AN ALTERNATE FOUNDATION DESIGN ON SHEET SR-400 CAN BE UTILIZED OR OTHER FOUNDATIONS APPROVED BY A REGISTERED PROFESSIONAL ENGINEER AND UNIRAC.
- DRAINAGE SHALL BE DIRECTED AWAY FROM PILES. PILES SHALL NOT BE PLACED IN SWALES, DRAINAGE AREAS OR WHERE WATER MAY BE ALLOWED TO FLOW OR STAND WITHOUT SPECIFIC ALLOWANCE IN WRITING FROM UNIRAC. ALL POSSIBLE EFFORTS SHALL BE MADE TO PREVENT WATER FROM FLOWING OR PONDING AROUND OR NEAR TO THE PILES.
- PILES MAY NOT BE PAINTED PRIOR TO INSTALLATION OF THE RACKING SYSTEM. AFTER INSTALLATION OF THE COMPLETE RACKING SYSTEM, PILES MAY BE PAINTED AT THE CONTRACTORS/CLIENTS DISCRETION. NO ADJUSTMENTS MAY BE MADE AFTER THE PILES HAVE BEEN PAINTED.
- PILES DRIVEN TOO SHALLOW OR TOO DEEP WILL NEED TO BE ALTERED AT THE CONTRACTORS EXPENSE. UNIRAC HAS PROVIDED TOLERANCES IN THE GFT INSTALLATION GUIDE THAT SHALL BE FOLLOWED.
- IT IS THE CONTRACTORS RESPONSIBILITY TO DETERMINE THE MEANS AND METHODS FOR DRIVING PILES. THE PILE INSTALLATION METHOD UTILIZED DURING ONSITE PILE TESTING SHALL BE THE SAME AS INSTALLATION. THE CONTRACTOR MUST INSTALL PILES UTILIZING A PILE DRIVING RIG WITH A PERCUSSION PNEUMATIC HAMMER. A VIBRATORY PILE DRIVER IS NOT RECOMMENDED. SEE PILE TEST PLAN FOR DETAILS.

- THE RACKING DISTRIBUTOR SHALL NOT BE HELD RESPONSIBLE FOR DAMAGE TO THE PILE AFTER IT ARRIVES TO THE SITE OR THE POINT OF AGREED DROP OFF.
- IF DAMAGE OCCURS WHERE GALVANIZATION IS REMOVED FROM THE PILE, THE PILE SHALL BE TOUCHED UP WITH GALVANIZATION OF EQUAL THICKNESS PRIOR TO INSTALLATION AT THE CONTRACTOR'S EXPENSE.
- IT SHALL BE THE CONTRACTORS RESPONSIBILITY TO ENSURE THAT VIBRATIONS FROM DRIVING EQUIPMENT AND PILE INSTALLATION DO NOT AFFECT ANY ADJACENT PROPERTY STRUCTURES. THE CONTRACTOR SHALL BE HELD LIABLE FOR DAMAGE TO THE ADJACENT PROPERTY IF DAMAGE OCCURS.
- ANY EXCAVATIONS NEAR THE PILE SHALL NOT BE MADE CLOSER THAN 2 FEET FROM PILE OR DEEPER THAN 2 FEET FROM GRADE. IF EXCAVATIONS ARE NECESSARY, THEY SHALL BE ON THE EAST OR WEST SIDE OF THE PILE. TEMPORARY AND SHALL BE COMPACTED PER THE ENGINEER OF RECORD'S RECOMMENDATIONS. NORTH SOUT EXCAVATIONS SHALL BE A MINIMUM OF 3 FEET FROM THE PILE. IF EXCAVATIONS EXCEED THESE DIMENSIONAL REQUIREMENTS, THE CONTRACTOR SHALL NOTIFY UNIRAC. THE ENGINEER OF RECORD SHALL BE INFORMED OF ANY EXCAVATION AND COMPACTION EFFORTS ON THE SITE.
- PILES MAY NOT BE ALTERED IN ANY WAY WITHOUT UNIRAC WRITTEN APPROVAL. UNLESS IT IS TO CUT A PILE FOR USE IN THE CONCRETE FOUNDATION OPTION.
- PILES HAVE BEEN DESIGNED FOR STATIC LOADING UNDER THE DESIGN CRITERIA IN GENERAL NOTE 15.

QUALITY ASSURANCE AND SPECIAL INSPECTION:

- TESTING LABORATORY: RETAINED BY OWNER AND SATISFACTORY TO ENGINEER OF RECORD (THROUGH UNIRAC) AND GOVERNING CODE AUTHORITY TO PERFORM REQUIRED TESTS AND INSPECTIONS OF THIS CONTRACT AND APPLICABLE CODE. THE TYPE AND FREQUENCY OF SPECIAL INSPECTION, STRUCTURAL TESTING AND SUBSEQUENT REPORTING SHALL CONFORM TO THE REQUIREMENTS OF THE INTERNATIONAL BUILDING CODE (IBC).

CONCRETE:

- ALL ASPECTS OF WORK PERTAINING TO THE CONCRETE CONSTRUCTION SHALL BE IN ACCORDANCE WITH ACI 318-14, "BUILDING CODE REQUIREMENTS FOR STRUCTURAL CONCRETE" AND THE LATEST EDITION OF "SPECIFICATIONS FOR STRUCTURAL CONCRETE FOR BUILDINGS" ACI 301, WITH MODIFICATIONS AS NOTED ON THE PROJECT DRAWINGS AND/OR SPECIFICATIONS.
- HOT WEATHER CONCRETING SHALL CONFORM TO ACI 305, "HOT WEATHER CONCRETING".
- COLD WEATHER CONCRETING SHALL CONFORM TO ACI 306, "COLD WEATHER CONCRETING".
- ALL MIX DESIGNS SHALL BE DESIGNED BY A QUALIFIED TESTING LABORATORY AND SHALL BE WET STAMPED BY A CIVIL ENGINEER LICENSED IN THE JURISDICTION OF THE PROJECT. AS STIPULATED IN IBC CHAPTER 19.
- TYPE II PORTLAND CEMENT SHALL BE USED AT ALL CONCRETE ALTERNATE FOUNDATION LOCATIONS FOR THE RACKING SYSTEM - WHERE CONCRETE IS REQUIRED AS AN ALTERNATE SOLUTION. (TYPE V CEMENT SHALL BE USED WHERE THE CONCRETE IS IN CONTACT WITH SOIL CONTAINING SULFATES IN EXCESS OF 3000 PPM. CONCRETE THAT WILL BE EXPOSED TO SULFATE-CONTAINING SOLUTIONS SHALL COMPLY WITH IBC CHAPTER 19 AND ACI 318 SEVERE AND VERY SEVERE SULFATE EXPOSURES AS IDENTIFIED IN THE PROJECT GEOTECHNICAL REPORT, THE WATER CEMENT RATIO SHALL NOT EXCEED 0.44.)
- IN THE PRESENCE OF REACTIVE AGGREGATE, CLASS F FLY ASH OR OTHER ASR MITIGATING ADMIXTURE SHALL BE INCORPORATED IN THE MIX SUCH THAT THE EXPANSION PRODUCED BY THE MORTAR-BAR METHOD (ASTM C1567) USING BLENDED AGGREGATES IS LESS THAN 0.1% AT 14 DAYS IMMERSED IN SOLUTION. WHERE CLASS F FLY ASH IS SELECTED AS A SUPPLEMENTAL ADMIXTURE, THE LOSS OF IGNITION SHALL BE LIMITED TO 2%. THE CONTRACTOR SHALL SUBMIT ALL CERTIFICATES SHOWING THE FLY ASH IS IN ACCORDANCE WITH ASTM 6618.
- DO NOT USE CONCRETE OR GROUT CONTAINING CHLORIDES. WATER SHALL CONTAIN A CHLORIDE CONTENT LESS THAN 1000 PPM AS C1. DO NOT USE CONCRETE CONTAINING ALKALI-CARBONATE AND BICARBONATES PRESENT IN AGGREGATE IN EXCESS OF 1000 PPM. TESTS FOR THEIR EFFECT ON SETTING TIME AND 28 DAY STRENGTH SHALL BE EVALUATED.
- HARD ROCK CONCRETE AGGREGATE SHALL CONFORM TO ALL REQUIREMENTS AND TESTS OF THE ASTM C33 CLASS DESIGNATION 35 AND PROJECT SPECIFICATIONS. EXCEPTIONS MAY BE USED ONLY WITH APPROVAL OF THE STRUCTURAL ENGINEER. PROVIDE CONCRETE MIX DESIGN WITH PROVEN SHRINKAGE CHARACTERISTICS OF LESS THAN 0.0005 INCHES/INCH.
- MAXIMUM SIZED AGGREGATE OF 0.75".
- SLUMP RANGE OF 3" ± 1" PER ASTM C143.
- CONCRETE PLACEMENT SHALL BE IN ACCORDANCE WITH ACI STANDARD 304 AND PROJECT SPECIFICATIONS.
- THE UNIRAC PILE SHALL BE CENTERED IN THE HOLE TO MAXIMIZE CONCRETE COVER AND THE HOLE SHALL BE CENTERED IN THE SPECIFIED LOCATION TO ALLOW FOR RACKING INSTALLABILITY.
- THE TOP OF THE CONCRETE SHALL BE SMOOTHED AND SLOPED AT 2% TO FACILITATE POSITIVE DRAINAGE AWAY FROM THE UNIRAC PILE.
- CONCRETE CHLORIDE PERMEABILITY SHALL BE CLASSIFIED AS HAVING "NEGLIGIBLE" TO "VERY LOW" CHLORIDE ION PERMEABILITY PER ASTM C1202.
- CONCRETE SHOULD BE PLACED IN A CONTINUOUS FLOW WITHOUT SEGREGATING THE CONCRETE. DO NOT ALLOW CONCRETE TO FREE FALL MORE THAN 5 FEET UNLESS MEASURES ARE TAKEN TO ENSURE THAT CONCRETE DOES NOT HIT THE SIDES OF THE EXCAVATION DURING FREE FALL.
- MECHANICALLY VIBRATE THE CONCRETE AT EACH PIER.
- PRECAUTIONS SHOULD BE TAKEN DURING THE INSTALLATION OF PIERS TO MINIMIZE THE POSSIBILITY OF CAVING. PIER EXCAVATIONS SHOULD BE FILLED WITH CONCRETE AS SOON AFTER DRILLING AND INSPECTION AS POSSIBLE. SONOTUBES (OR EQUIVALENT) CAN BE UTILIZED, AS REQUIRED, ONLY IN THE UPPER 2 FT. OF THE AUGERED/DRILLED HOLE.
- CONCRETE MIXING OPERATION SHALL CONFORM TO ASTM C-94.
- AGGREGATE FOR HARDROCK CONCRETE SHALL CONFORM TO ALL REQUIREMENTS AND TESTS OF THE ASTM C-33 AND PROJECT SPECIFICATIONS. EXCEPTIONS MAY BE USED ONLY WITH THE PERMISSION OF THE ENGINEER OF RECORD.
- THE DENSITY OF CONCRETE SHALL BE BETWEEN 140 PCF TO 150 PCF. THE 28 DAY STRENGTH OF CONCRETE SHALL BE 2500 PSI WITH A MAXIMUM WATER-CEMENT RATIO OF 0.40.

SHEET INDEX	
SHEET NUMBER	SHEET TITLE
SR - 100	GENERAL STRUCTURAL RACKING NOTES
SR - 200	GFT TABLE CROSS-SECTION AND PARTS LIST (20 DEGREE TILT)
SR - 201	GFT E-W BEAM LOCATION OPTIONS (20 DEGREE TILT)
SR - 300	GFT TABLE CROSS-SECTION AND PARTS LIST (30 DEGREE TILT)
SR - 301	GFT E-W BEAM LOCATION OPTIONS (30 DEGREE TILT)
SR - 400	FOUNDATION OPTION 1 DETAILS
SR - 401	FOUNDATION OPTION 2 DETAILS
SR - 402	FOUNDATION OPTION 3 DETAILS
SR - 403	FOUNDATION OPTION 4 DETAILS
SR - 500	FOUNDATION OPTION 5 DETAILS
	RACKING DETAILS

REVISION BLOCK		
MARK	DATE	DESCRIPTION
0	08/14/2019	Original Release
1	08/22/2019	Rev-1
2	03/30/2020	Rev-2

OWNER/CLIENT:

ENGINEERING CONSULTANT:

PROFESSIONAL SEAL

SEE STATE SPECIFIC STAMPED & SIGNED GFT CERTIFICATION LETTER

UNIRAC'S GFT
GROUND FIXED TILT
STRUCTURAL RACKING DRAWINGS

1411 Broadway Boulevard, NE
Albuquerque, New Mexico 87102
Phone: (505) 242-6411
Fax: (505) 242-6412
www.unirac.com

ALL INFORMATION PROVIDED HEREIN IS CONFIDENTIAL AND PROPRIETARY AND IS SOLE PROPERTY OF UNIRAC, INC. REPRODUCTION OR TRANSMISSION IN ANY FORM OR BY ANY MEANS WITHOUT THE WRITTEN AND AUTHORIZED CONSENT OF UNIRAC, INC. IS STRICTLY PROHIBITED.

PROJECT NUMBER: GFT
ENGINEERED BY: JRS
DRAFTED BY: JRS
REVIEWED BY: EP
ORIGINAL RELEASE DATE: 08/14/2019
DRAWING SHEET SIZE: D - 24x36

SHEET TITLE
GENERAL
STRUCTURAL RACKING
NOTES

SHEET NUMBER
SR-100
SHEET
1 of 11

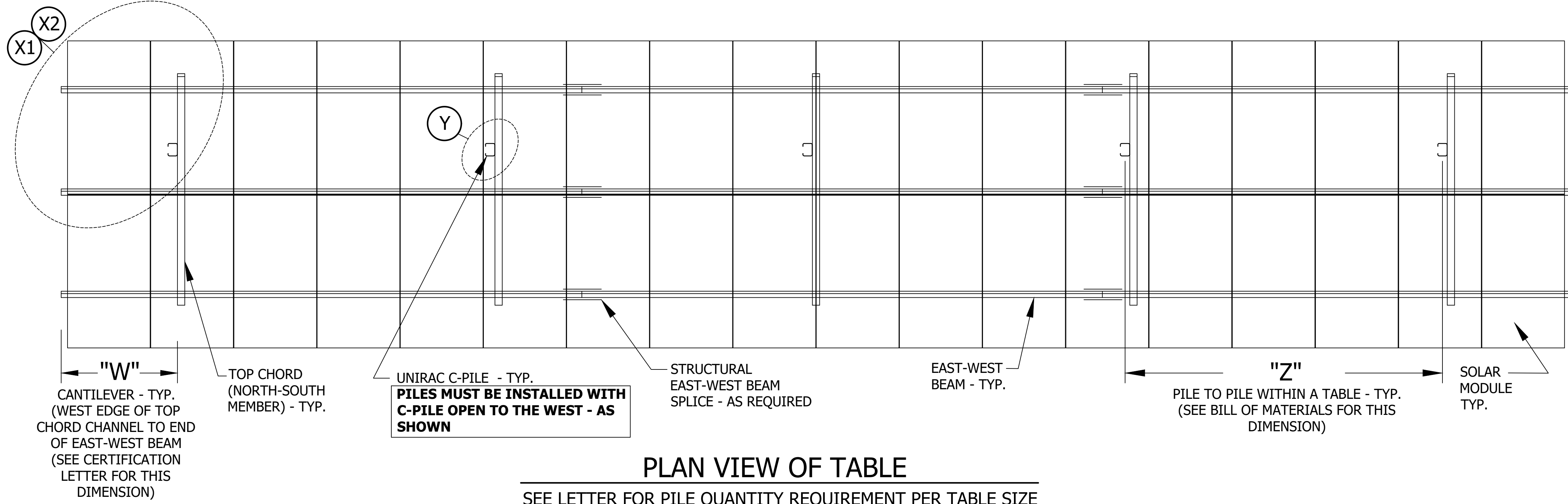

20° 20-24 in. NOM FRONT EDGE	
MODULE LENGTH (in.)	FRONT EDGE HEIGHT (in.)
77	22
83	20

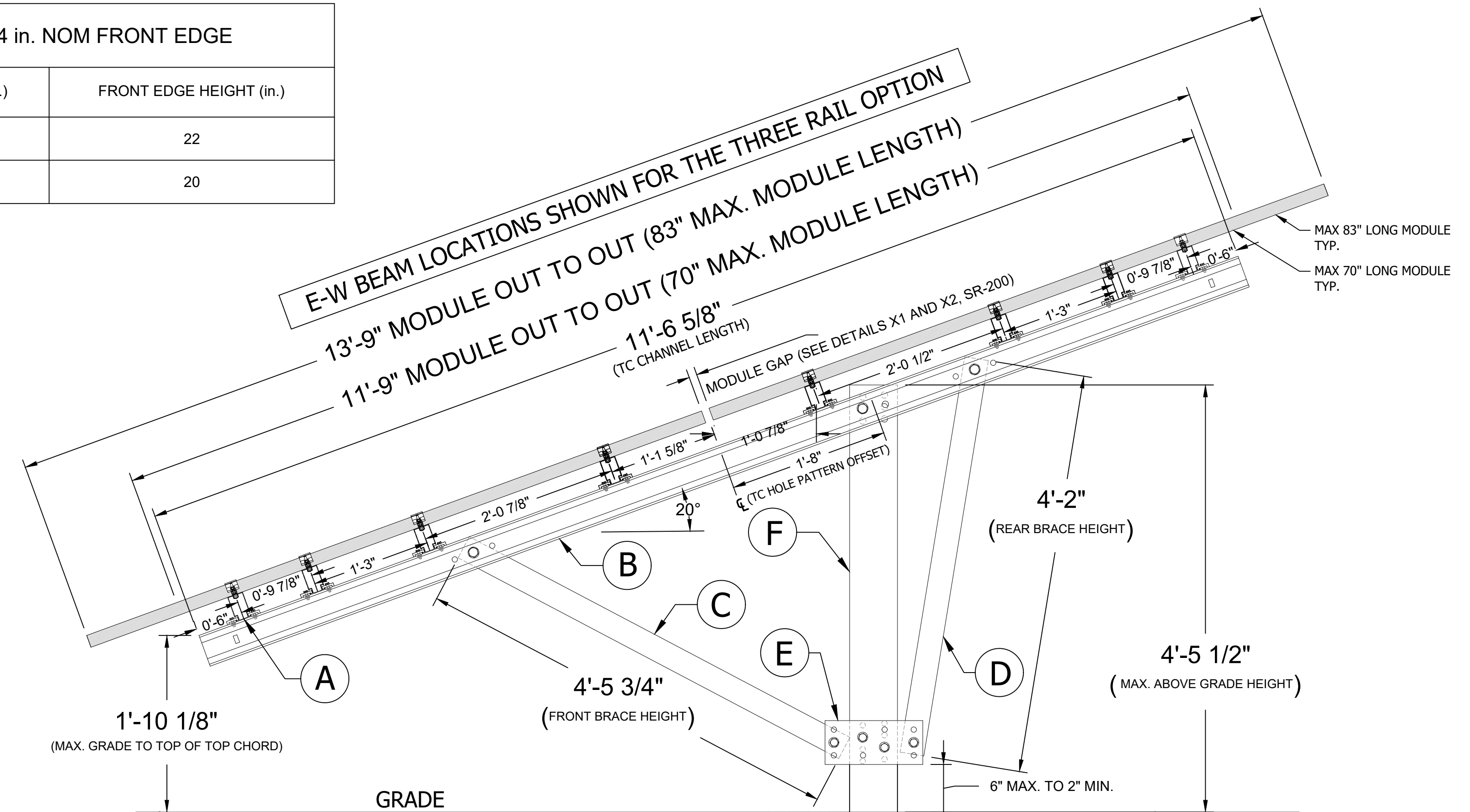

RACKING DIMENSION NOTES:

- THIS CROSS SECTION AND DIMENSIONS SHOWN ARE SPECIFIC TO AN 83" LONG MODULE AND A 70" LONG MODULE. ACTUAL MODULE LENGTHS WILL BE LESS THAN OR EQUAL TO WHAT IS SHOWN BASED ON THE ACTUAL SOLAR MODULE SELECTED. REFER TO THE STATE SPECIFIC CERTIFICATION LETTER FOR MORE INFORMATION ON THE LIMITS OF THIS REGION SPECIFIC RACKING DESIGN.
- FINE TUNE ADJUSTMENTS IN THE EAST-WEST BEAM TO TOP CHORD CHANNEL CONNECTIONS EXIST. SEE SHEET SR-500 FOR ALL RACKING CONNECTION DETAILS. REFER TO THE GFT INSTALLATION GUIDE FOR ADDITIONAL INFORMATION.
- ALL DIMENSIONS SHOWN WITH PARENTHESIS (), ARE OPTIMUM DIMENSIONS THAT MAY VARY SLIGHTLY DUE TO THE FOLLOWING; INSTALLATION SYSTEM USING DIFFERENT HOLE OPTIONS, VARIANCE IN THE PILE STICK-UP HEIGHT, MODULE SELECTION, OR VARIANCE IN THE FINISHED/EXISTING GRADE. ALL OTHER DIMENSIONS ARE FIXED.

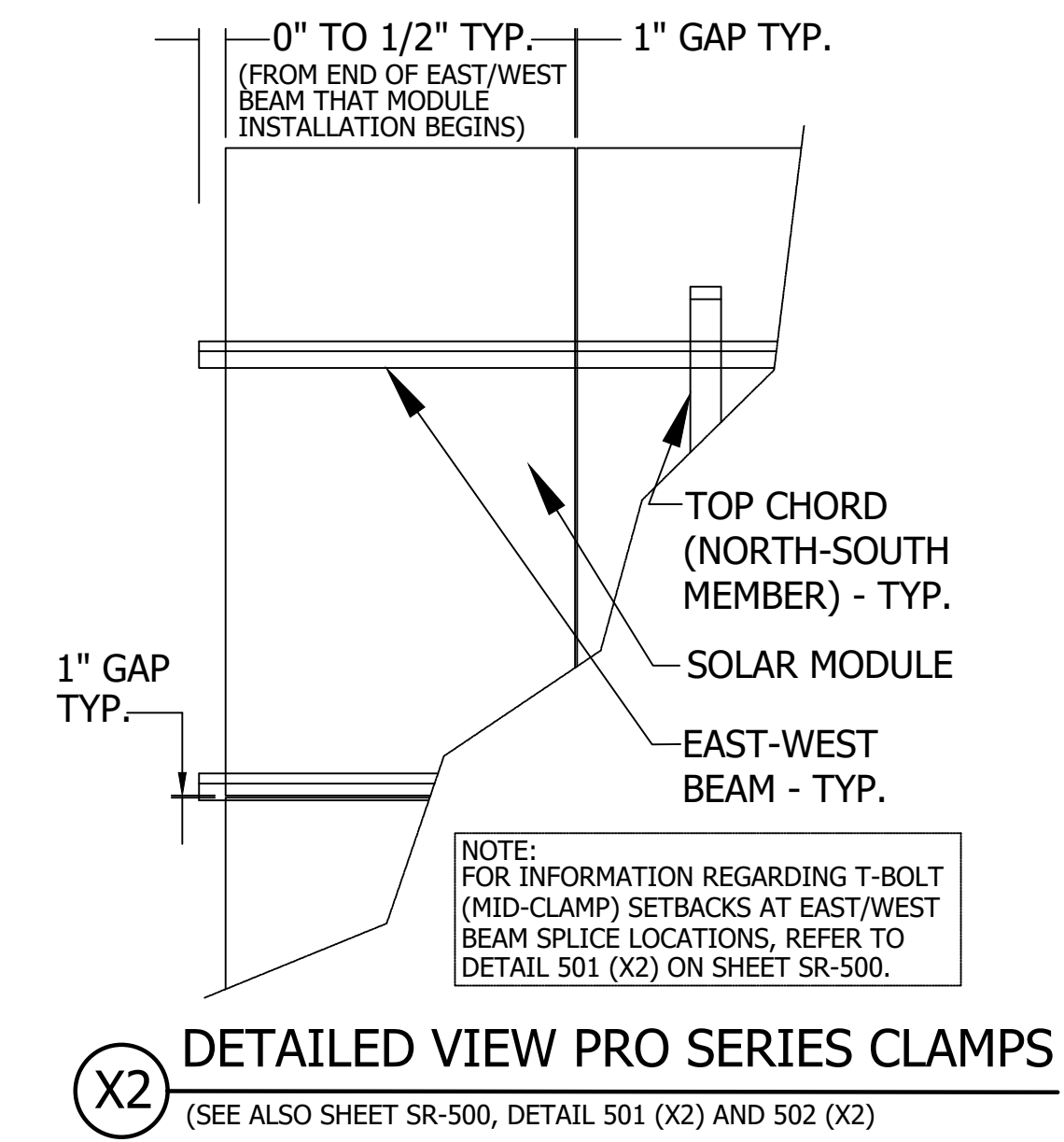
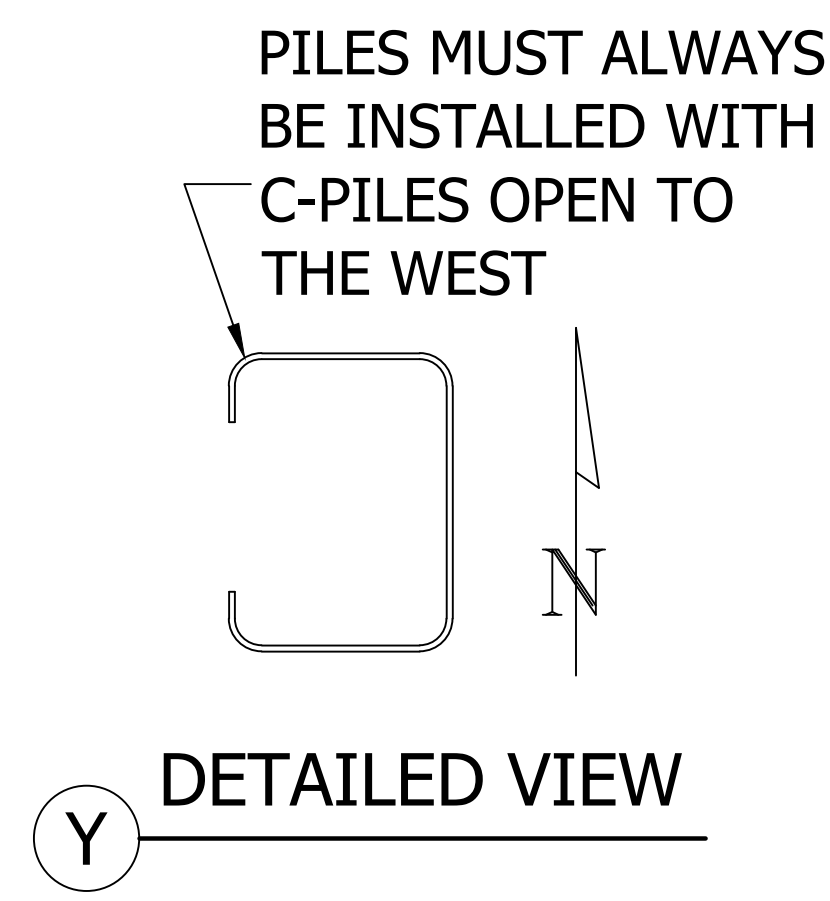
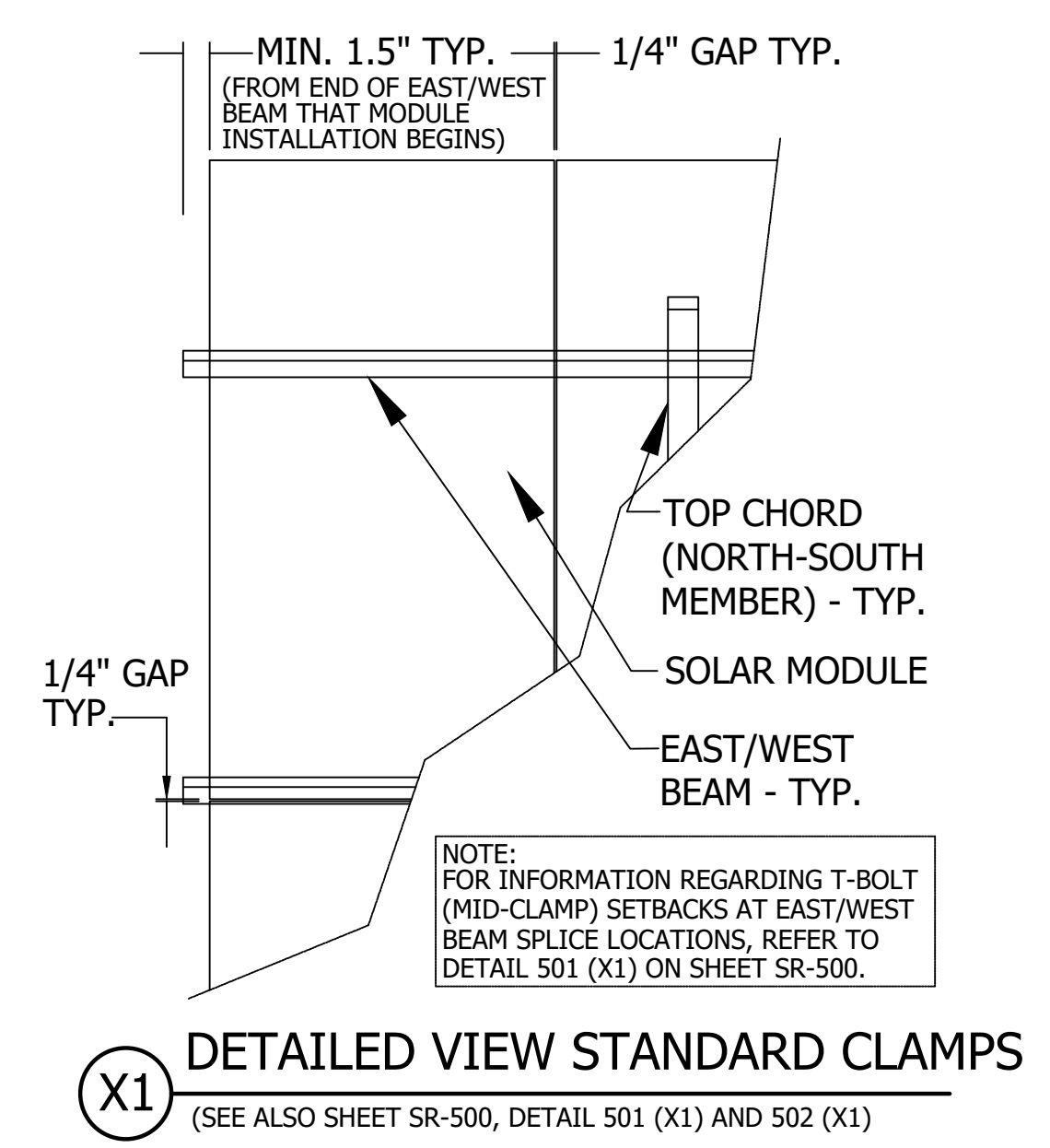

GFT PARTS LIST				
REF NUMBER	PART DESCRIPTION	CATALOG #	GAUGE/ THICKNESS	FINISH
A	ALUMINUM E-W BEAM (166" OR 246")	411166M OR 411246M		SEE SHEET SR-100
B	TOP CHORD CHANNEL	404036		SEE SHEET SR-100
C	FRONT DIAGONAL BRACE (20°)			SEE SHEET SR-100
D	REAR DIAGONAL BRACE (20°)	404031		SEE SHEET SR-100
E	DIAGONAL BRACE PLATE			SEE SHEET SR-100
F	C-PILE (12.5 FT OR 15 FT)	404001 OR 404002		SEE SHEET SR-100

REVISION BLOCK		
MARK	DATE	DESCRIPTION
0	08/14/2019	Original Release
1	08/22/2019	Rev-1
2	09/30/2020	Rev-2

OWNER/CLIENT:

ENGINEERING CONSULTANT:

PROFESSIONAL SEAL

SEE STATE SPECIFIC STAMPED & SIGNED GFT CERTIFICATION LETTER

UNIRAC'S GFT
GROUND FIXED TILT
STRUCTURAL RACKING DRAWINGS

UNIRAC
1411 Broadway Boulevard, NE
Albuquerque, New Mexico 87102
Phone: (505) 242-6411
Fax: (505) 242-6412
www.unirac.com

ALL INFORMATION PROVIDED HEREIN IS CONFIDENTIAL AND PROPRIETARY AND IS SOLE PROPERTY OF UNIRAC, INC. REPRODUCTION AND/OR DISTRIBUTION WITHOUT WRITTEN PERMISSION IS PROHIBITED AND WILL CONSTITUTE COPYRIGHT INFRINGEMENT UNDER U.S. LAW.

PROJECT NUMBER: GFT
ENGINEERED BY: JRS
DRAFTED BY: JRS
REVIEWED BY: EP
ORIGINAL RELEASE DATE: 08/14/2019
DRAWING SHEET SIZE: D - 24x36

SHEET TITLE
GFT TABLE CROSS-SECTION AND PARTS LIST (20 DEGREE TILT)

SHEET NUMBER
SR-200

SHEET 2 of 11

E-W BEAM LOCATION OPTIONS: UP TO 83"

E-W BEAM LOCATIONS FOR THE THREE RAIL OPTION

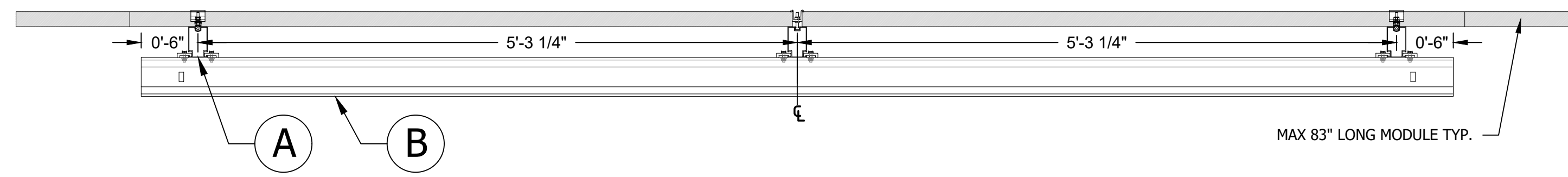

E-W BEAM LOCATIONS FOR THE FOUR RAIL OPTION

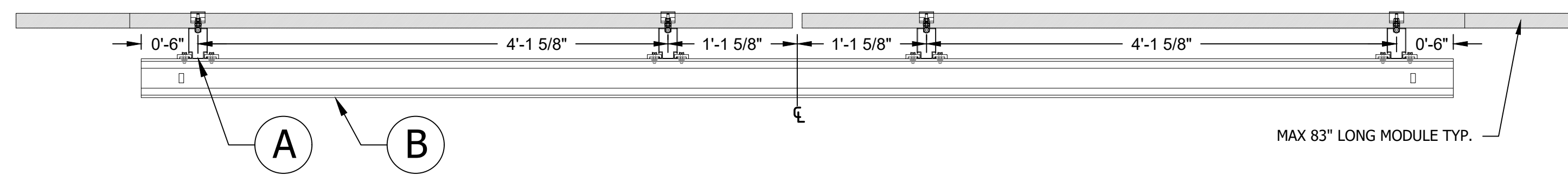

E-W BEAM LOCATIONS FOR THE FIVE RAIL OPTION

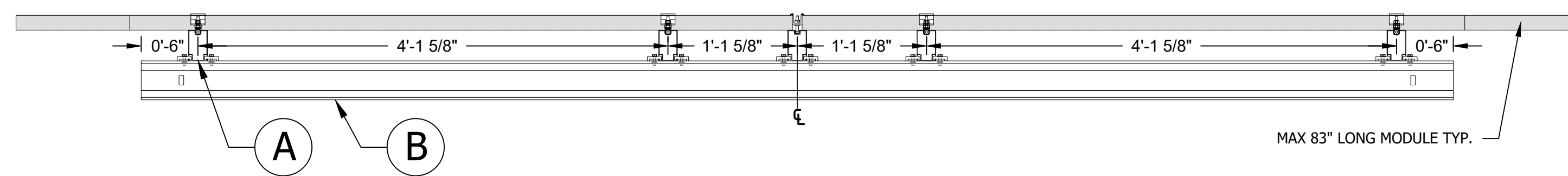

E-W BEAM LOCATIONS FOR THE SIX RAIL OPTION

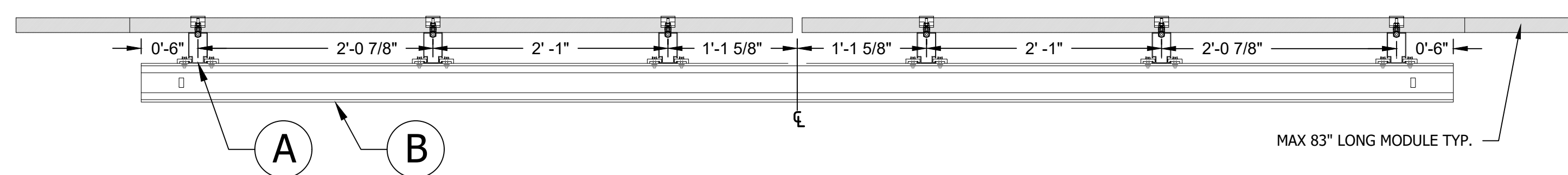

E-W BEAM LOCATIONS FOR THE EIGHT RAIL OPTION

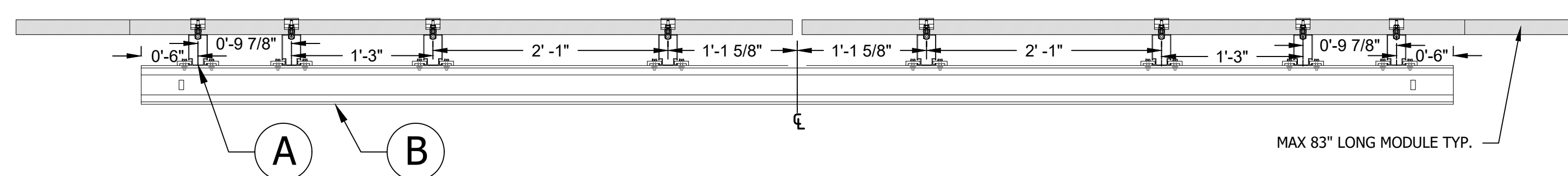

E-W BEAM LOCATION OPTIONS: UP TO 70"

E-W BEAM LOCATIONS FOR THE THREE RAIL OPTION

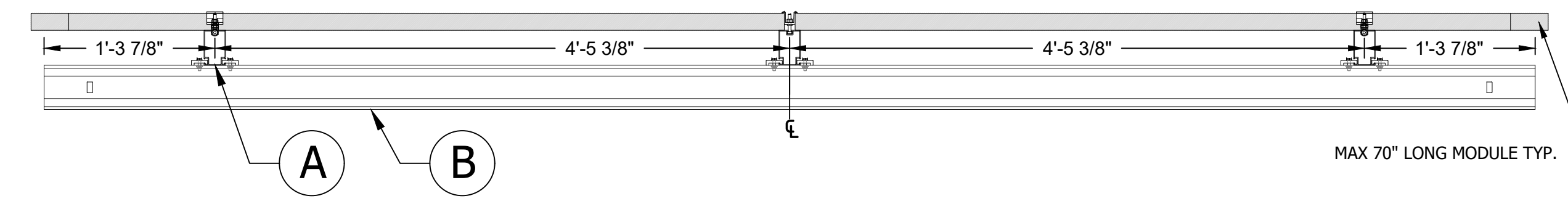

E-W BEAM LOCATIONS FOR THE FOUR RAIL OPTION

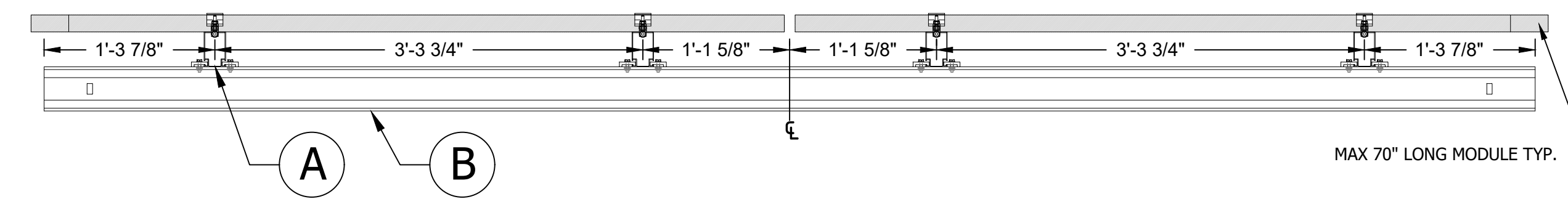

E-W BEAM LOCATIONS FOR THE FIVE RAIL OPTION

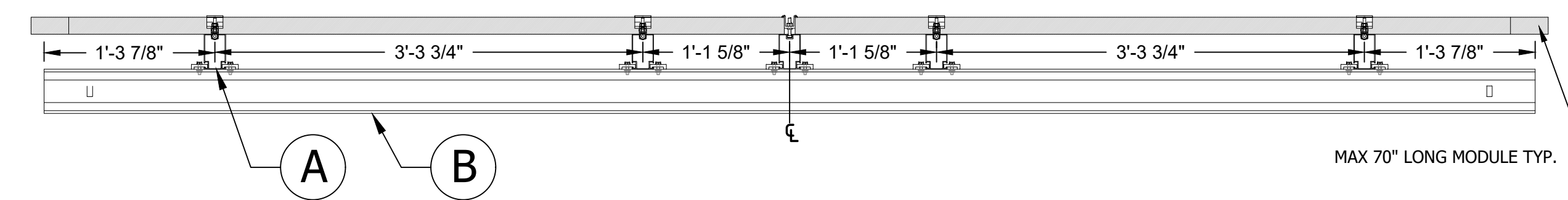

E-W BEAM LOCATIONS FOR THE SIX RAIL OPTION

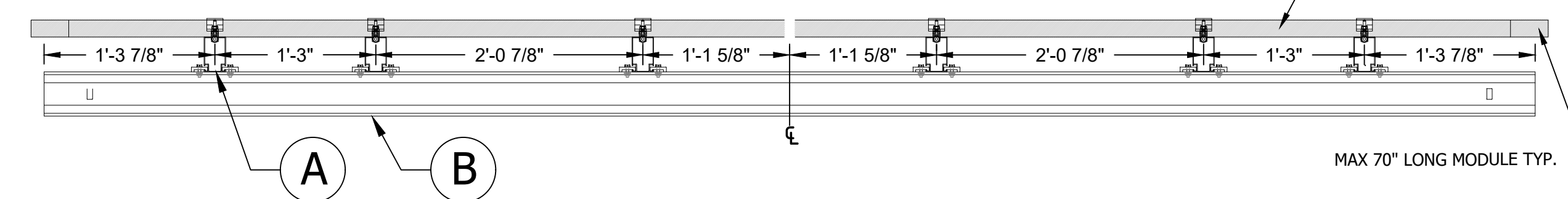

E-W BEAM LOCATIONS FOR THE EIGHT RAIL OPTION

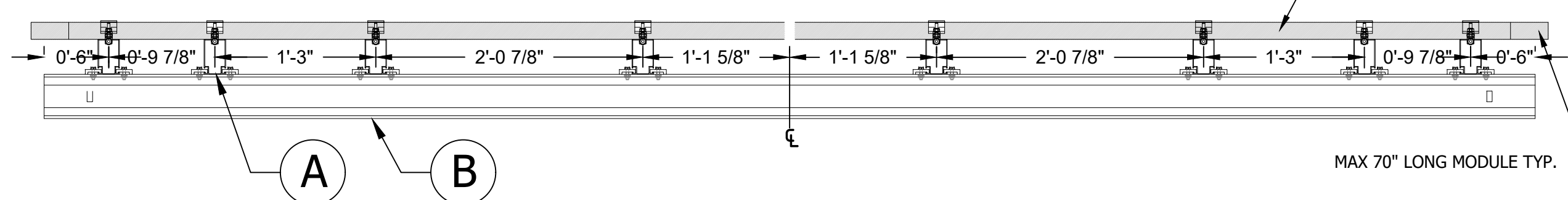

GFT PARTS LIST				
REF NUMBER	PART DESCRIPTION	CATALOG #	GAUGE/ THICKNESS	FINISH
A	ALUMINUM E-W BEAM (166" OR 246")	411166M OR 411246M		SEE SHEET SR-100
B	TOP CHORD CHANNEL	404036		SEE SHEET SR-100
C	FRONT DIAGONAL BRACE (20°)	404031		SEE SHEET SR-100
D	REAR DIAGONAL BRACE (20°)		SEE SHEET SR-100	
E	DIAGONAL BRACE PLATE		SEE SHEET SR-100	
F	C-PILE (12.5 FT OR 15 FT)	404001 OR 404002		SEE SHEET SR-100

REVISION BLOCK		
MARK	DATE	DESCRIPTION
0	08/14/2019	Original Release
1	08/22/2019	Rev-1
2	03/30/2020	Rev-2

OWNER/CLIENT:

ENGINEERING CONSULTANT:

PROFESSIONAL SEAL

SEE STATE SPECIFIC STAMPED & SIGNED GFT CERTIFICATION LETTER

UNIRAC'S GFT
 GROUND FIXED TILT
 STRUCTURAL RACKING DRAWINGS

1411 Broadway Boulevard NE
Albuquerque, New Mexico 87102
Phone: (505) 242-6411
Fax: (505) 242-6412
www.unirac.com

ALL INFORMATION PROVIDED HEREIN IS CONFIDENTIAL AND PROPRIETARY AND IS SOLE PROPERTY OF UNIRAC, INC. REPRODUCTION AND/OR DISTRIBUTION WITHOUT WRITTEN PERMISSION IS FORBIDDEN AND WILL CONSTITUTE COPYRIGHT INFRINGEMENT UNDER U.S. LAW.

PROJECT NUMBER:	GFT
ENGINEERED BY:	JRS
DRAFTED BY:	JRS
REVIEWED BY:	EP
ORIGINAL RELEASE DATE:	08/14/2019
DRAWING SHEET SIZE:	D' - 24x36

SHEET TITLE
GFT E-W BEAM
LOCATION OPTIONS
(20 DEGREE TILT)

SHEET NUMBER
SR-201

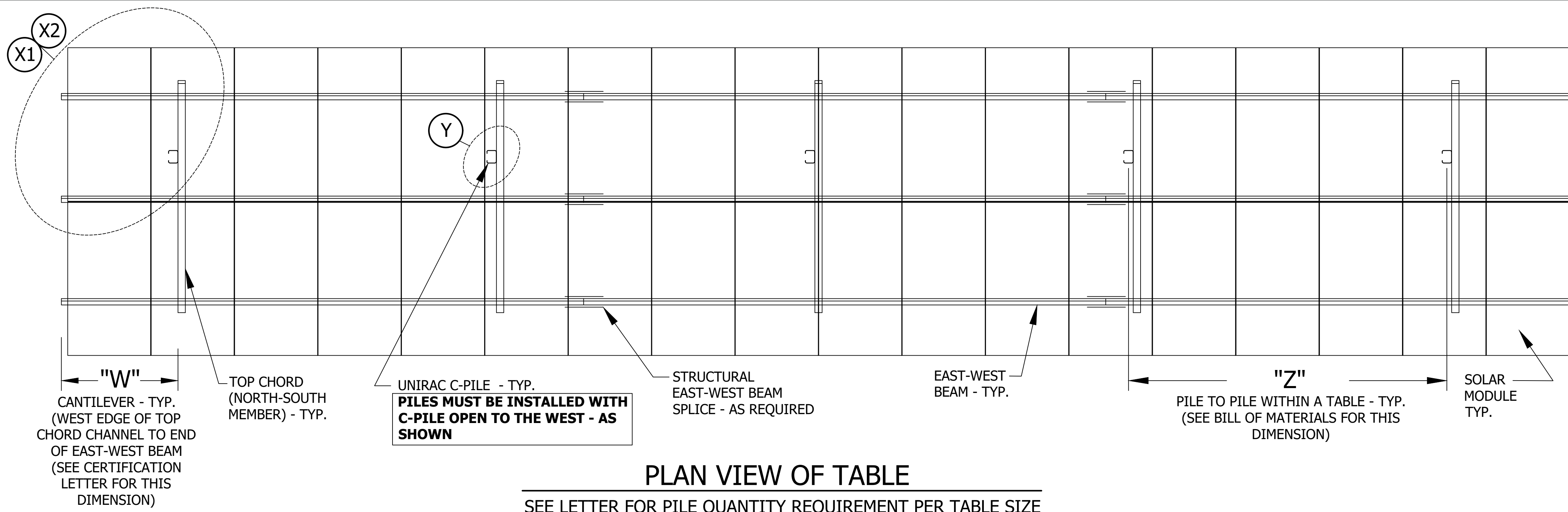

30° 25-30 in. NOM FRONT EDGE	
MODULE LENGTH (in.)	FRONT EDGE HEIGHT (in.)
77	28
83	26

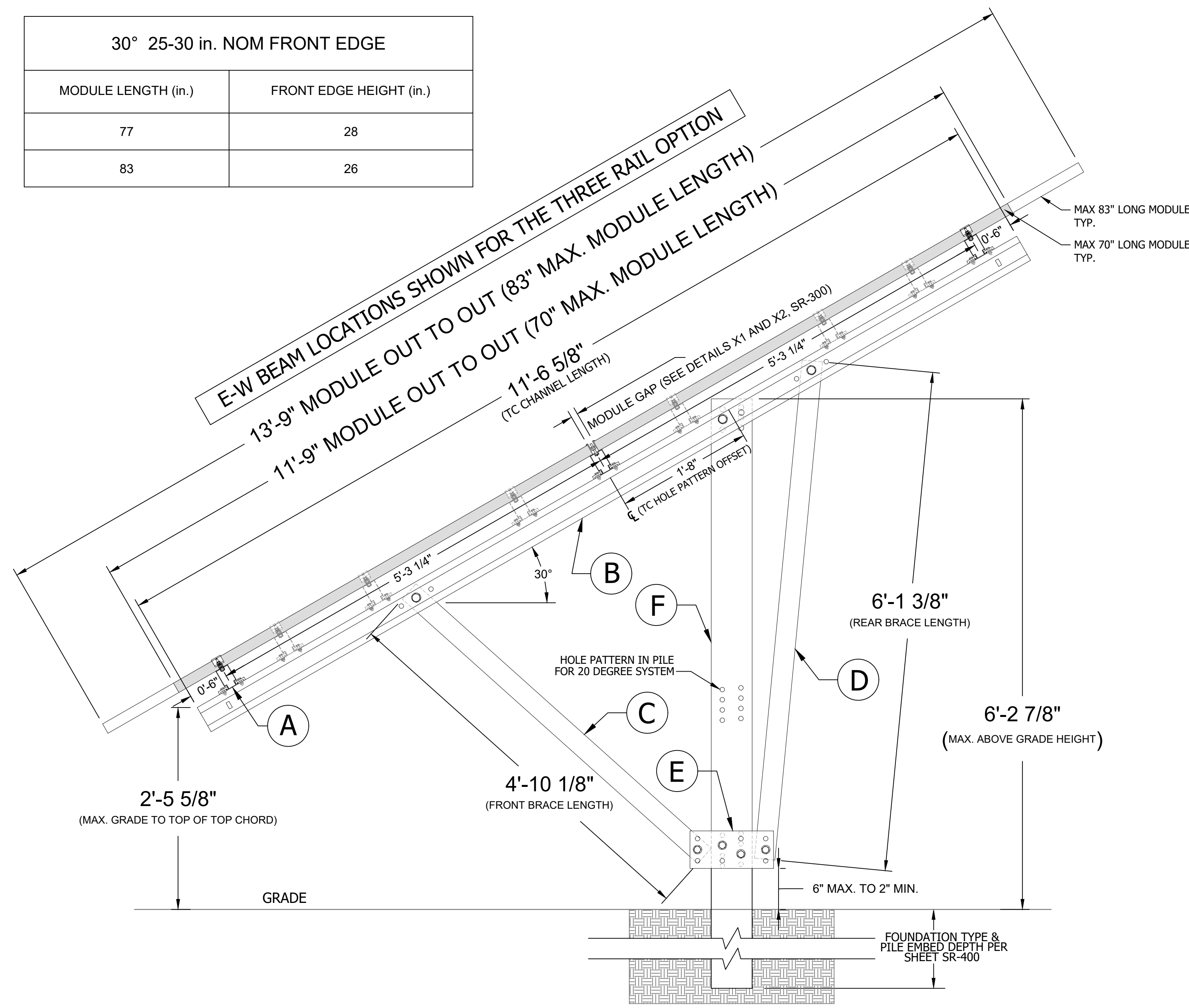

RACKING DIMENSION NOTES:

- THIS CROSS SECTION AND DIMENSIONS SHOWN ARE SPECIFIC TO AN 83" LONG MODULE AND A 70" LONG MODULE. ACTUAL MODULE LENGTHS WILL BE LESS THAN OR EQUAL TO WHAT IS SHOWN BASED ON THE ACTUAL SOLAR MODULE SELECTED. REFER TO THE STATE SPECIFIC CERTIFICATION LETTER FOR MORE INFORMATION ON THE LIMITS OF THIS REGION SPECIFIC RACKING DESIGN.
- FINE TUNE ADJUSTMENTS IN THE EAST-WEST BEAM TO TOP CHORD CHANNEL CONNECTIONS EXIST. SEE SHEET SR-500 FOR ALL RACKING CONNECTION DETAILS. REFER TO THE GFT INSTALLATION GUIDE FOR ADDITIONAL INFORMATION.
- ALL DIMENSIONS SHOWN WITH PARENTHESIS (), ARE OPTIMUM DIMENSIONS THAT MAY VARY SLIGHTLY DUE TO THE FOLLOWING: INSTALLATION SYSTEM USING DIFFERENT HOLE OPTIONS, VARIANCE IN THE PILE STICK-UP HEIGHT, MODULE SELECTION, OR VARIANCE IN THE FINISHED/EXISTING GRADE. ALL OTHER DIMENSIONS ARE FIXED.

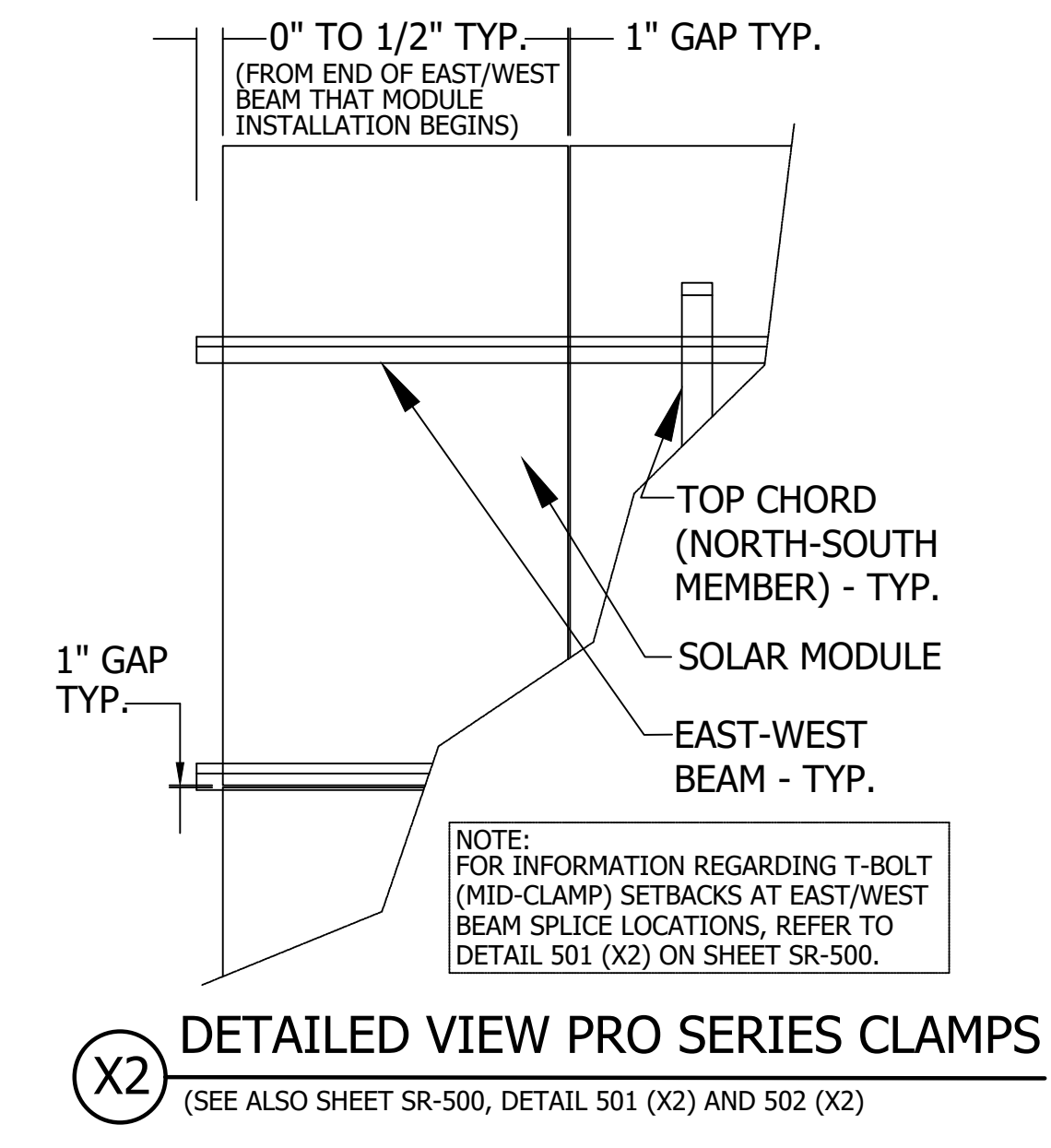
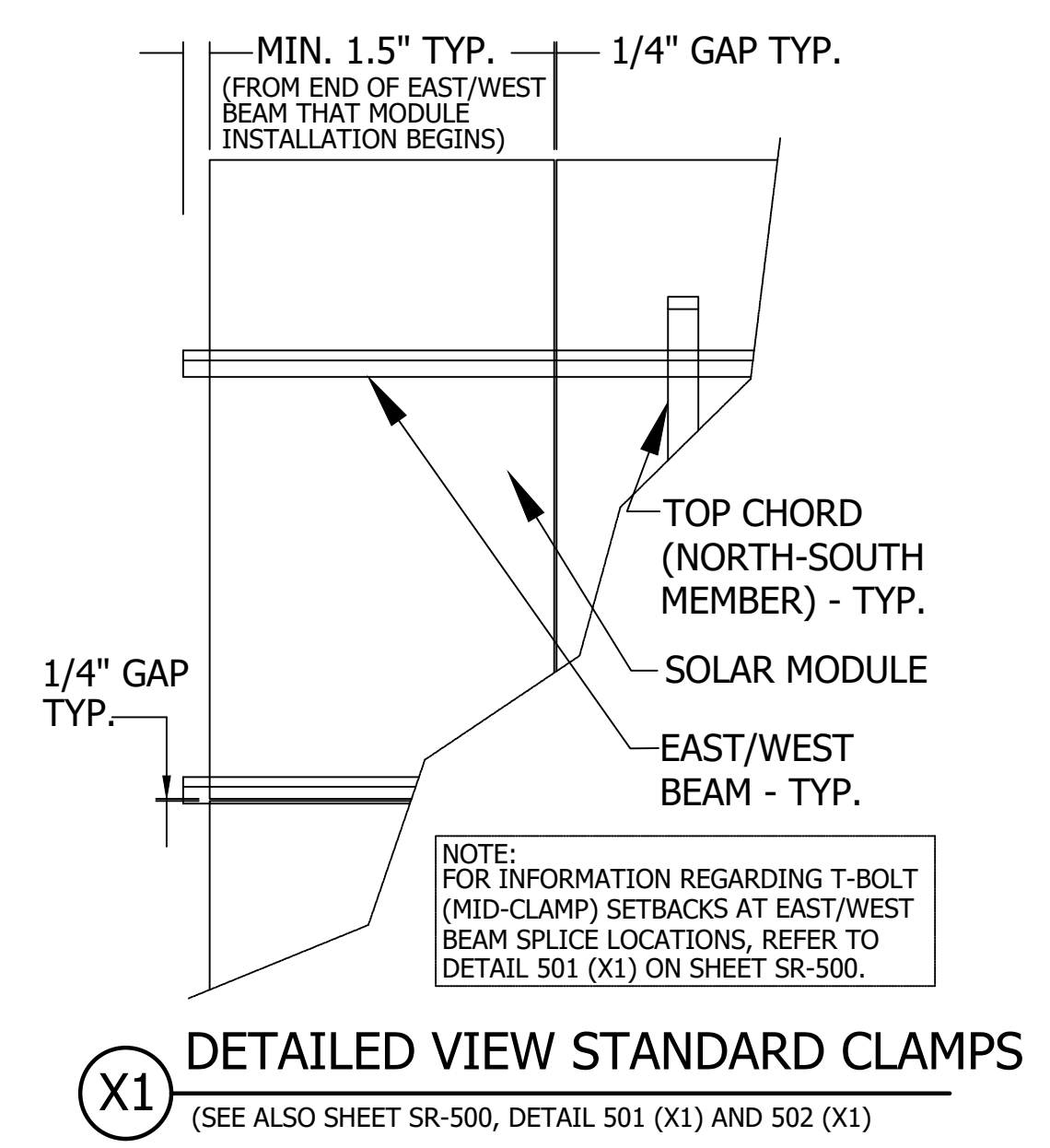
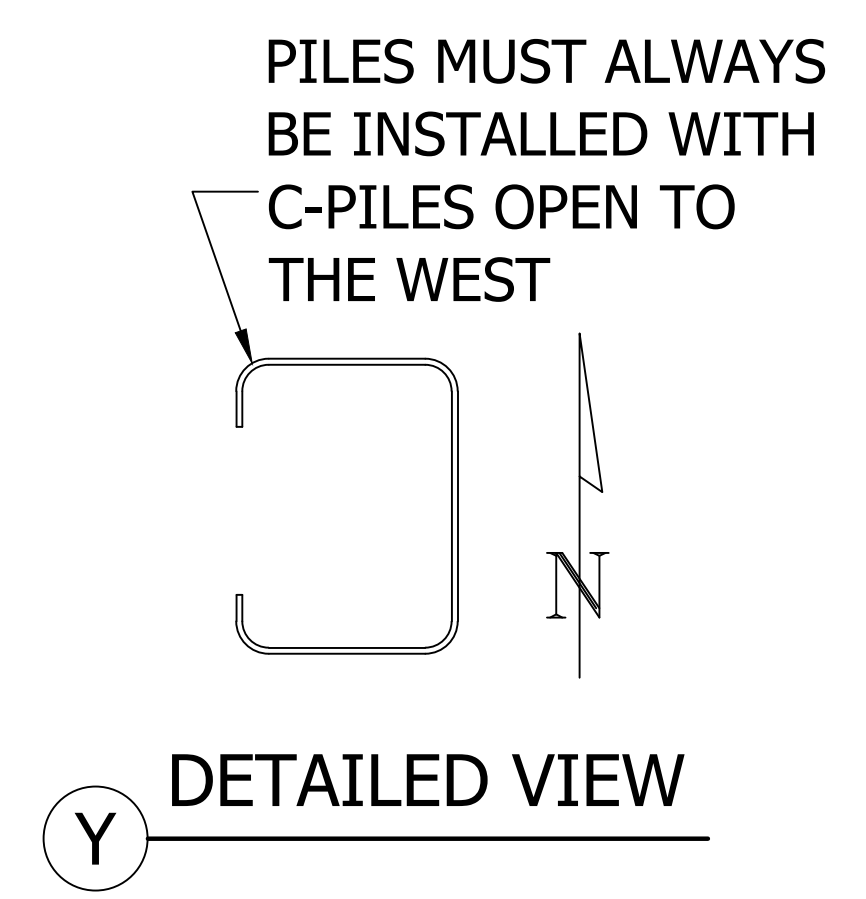

GFT PARTS LIST				
REF NUMBER	PART DESCRIPTION	CATALOG #	GAUGE/ THICKNESS	FINISH
A	ALUMINUM E-W BEAM (166" OR 246")	411166M OR 411246M		SEE SHEET SD-100
B	TOP CHORD CHANNEL	404036		SEE SHEET SD-100
C	FRONT DIAGONAL BRACE (30°)	404032		SEE SHEET SD-100
D	REAR DIAGONAL BRACE (30°)		SEE SHEET SD-100	
E	DIAGONAL BRACE PLATE			SEE SHEET SD-100
F	C-PILE (12.5 FT OR 15 FT)	404001 OR 404002		SEE SHEET SD-100

REVISION BLOCK		
MARK	DATE	DESCRIPTION
0	08/14/2019	Original Release
1	08/22/2019	Rev-1
2	03/30/2020	Rev-2

OWNER/CLIENT:

ENGINEERING CONSULTANT:

PROFESSIONAL SEAL

SEE STATE SPECIFIC STAMPED & SIGNED GFT CERTIFICATION LETTER

UNIRAC'S GFT
GROUND FIXED TILT
STRUCTURAL RACKING DRAWINGS

UNIRAC
1411 Broadway Boulevard, NE
Albuquerque, New Mexico 87102
Phone: (505) 242-6411
Fax: (505) 242-6412
www.unirac.com

PROJECT NUMBER: GFT
ENGINEERED BY: JRS
DRAFTED BY: JRS
REVIEWED BY: EP
ORIGINAL RELEASE DATE: 08/14/2019
DRAWING SHEET SIZE: D - 24x36

SHEET TITLE
GFT TABLE CROSS-SECTION AND PARTS LIST (30 DEGREE TILT)

SHEET NUMBER
SR-300

SHEET 4 of 11

E-W BEAM LOCATION OPTIONS: UP TO 83"

E-W BEAM LOCATIONS FOR THE THREE RAIL OPTION

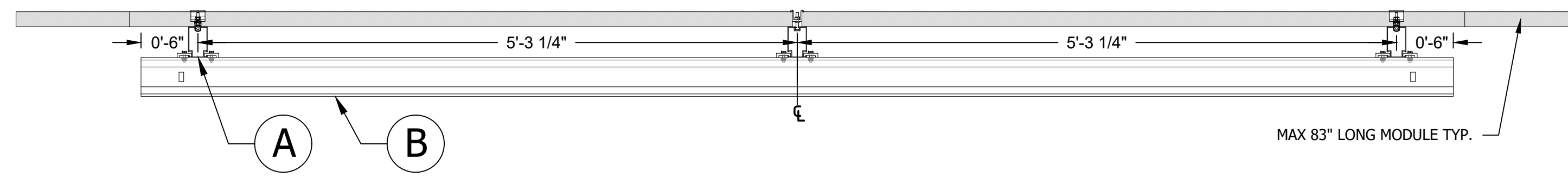

E-W BEAM LOCATIONS FOR THE FOUR RAIL OPTION

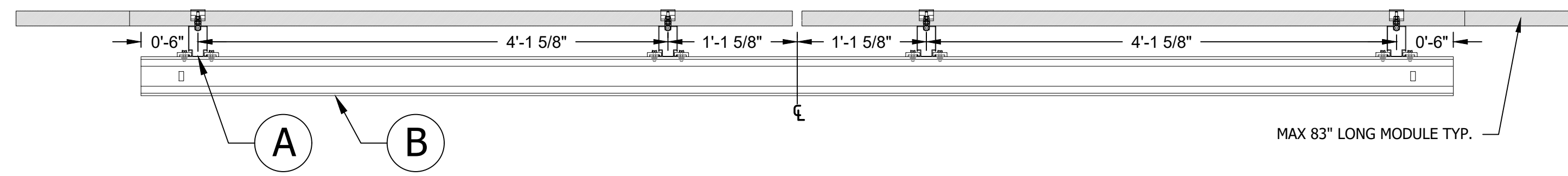

E-W BEAM LOCATIONS FOR THE FIVE RAIL OPTION

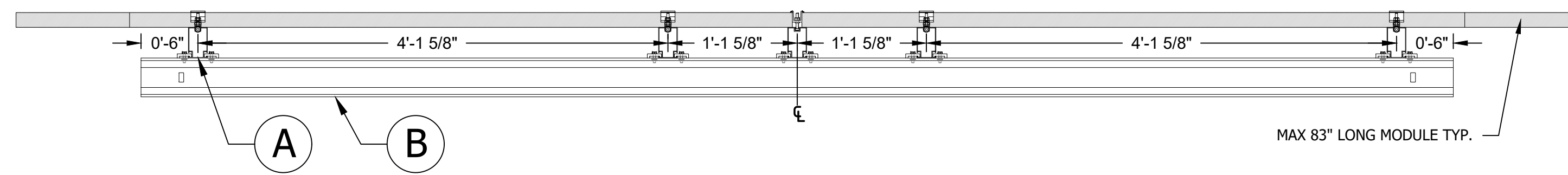

E-W BEAM LOCATIONS FOR THE SIX RAIL OPTION

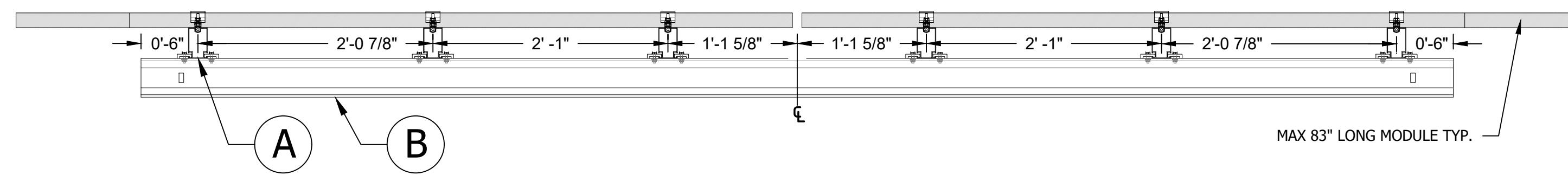

E-W BEAM LOCATIONS FOR THE EIGHT RAIL OPTION

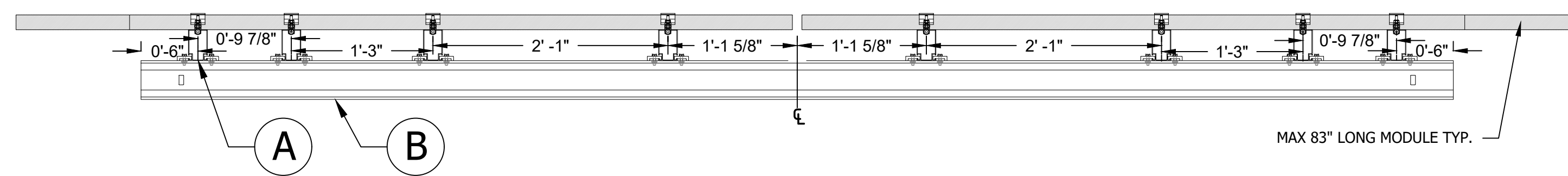

E-W BEAM LOCATION OPTIONS: UP TO 70"

E-W BEAM LOCATIONS FOR THE THREE RAIL OPTION

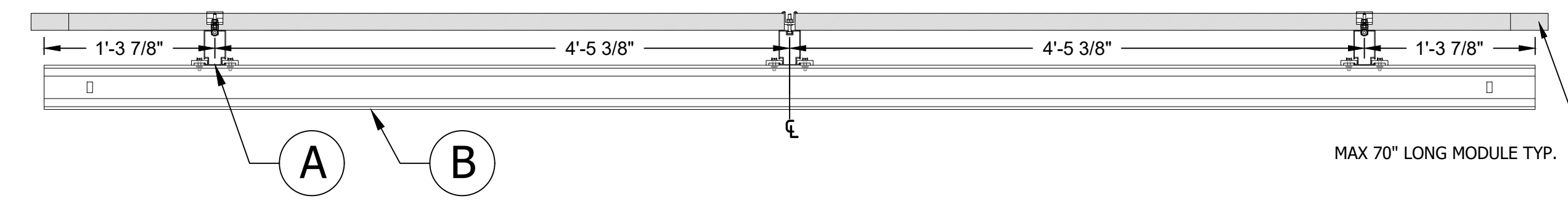

E-W BEAM LOCATIONS FOR THE FOUR RAIL OPTION

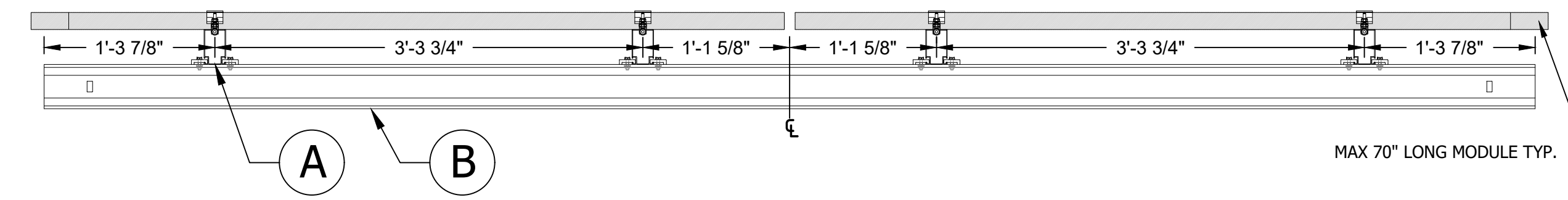

E-W BEAM LOCATIONS FOR THE FIVE RAIL OPTION

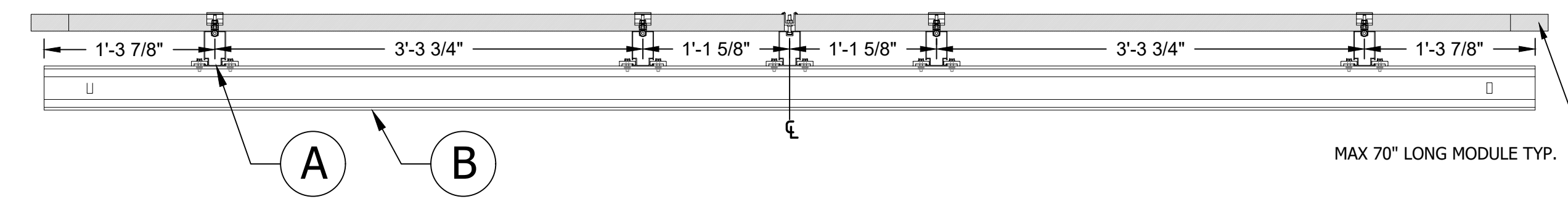

E-W BEAM LOCATIONS FOR THE SIX RAIL OPTION

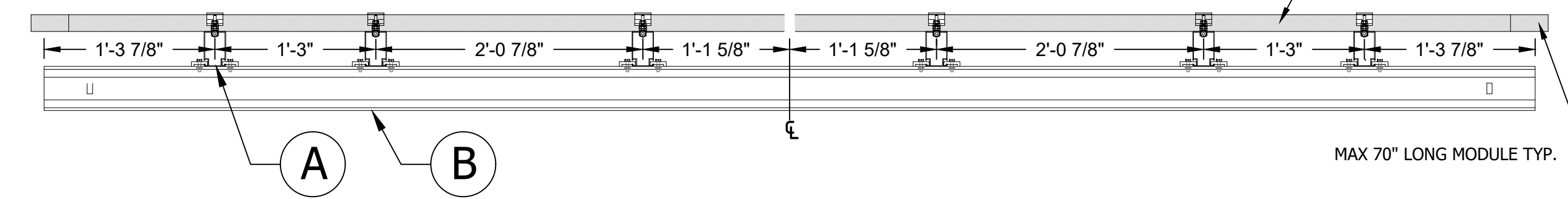

E-W BEAM LOCATIONS FOR THE EIGHT RAIL OPTION

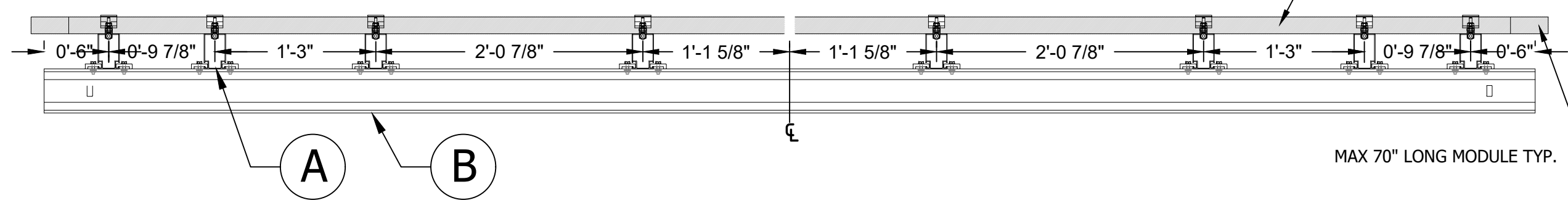

GFT PARTS LIST

REF NUMBER	PART DESCRIPTION	CATALOG #	GAUGE/ THICKNESS	FINISH
A	ALUMINUM E-W BEAM (166" OR 246")	411166M OR 411246M		SEE SHEET SR-100
B	TOP CHORD CHANNEL	404036		SEE SHEET SR-100
C	FRONT DIAGONAL BRACE (20°)	404031		SEE SHEET SR-100
D	REAR DIAGONAL BRACE (20°)		SEE SHEET SR-100	
E	DIAGONAL BRACE PLATE			SEE SHEET SR-100
F	C-PILE (12.5 FT OR 15 FT)	404001 OR 404002		SEE SHEET SR-100

REVISION BLOCK		
MARK	DATE	DESCRIPTION
0	08/14/2019	Original Release
1	08/22/2019	Rev-1
2	03/30/2020	Rev-2

OWNER/CLIENT:

ENGINEERING CONSULTANT:

PROFESSIONAL SEAL

SEE STATE SPECIFIC STAMPED & SIGNED GFT CERTIFICATION LETTER

UNIRAC'S GFT
GROUND FIXED TILT
STRUCTURAL RACKING DRAWINGS



1411 Broadway Boulevard, NE
Albuquerque, New Mexico 87102
Phone: (505) 242-6411
Fax: (505) 242-6412
www.unirac.com

ALL INFORMATION PROVIDED HEREIN IS CONFIDENTIAL AND PROPRIETARY AND IS SOLE PROPERTY OF UNIRAC, INC. REPRODUCTION AND DISTRIBUTION WITHOUT WRITTEN PERMISSION IS PROHIBITED AND WILL RESULT IN LEGAL ACTION UNDER FEDERAL LAWS.

PROJECT NUMBER:	GFT
ENGINEERED BY:	JRS
DRAFTED BY:	JRS
REVIEWED BY:	EP
ORIGINAL RELEASE DATE:	08/14/2019
DRAWING SHEET SIZE:	D - 24x36

SHEET TITLE
GFT E-W BEAM
LOCATION OPTIONS
(30 DEGREE TILT)

SHEET NUMBER
SR-301
SHEET 5 of 11

REVISION BLOCK		
MARK	DATE	DESCRIPTION
0	08/14/2019	Original Release
1	08/22/2019	Rev-1
2	03/30/2020	Rev-2

OWNER/CLIENT:

ENGINEERING CONSULTANT:

PROFESSIONAL SEAL

SEE STATE SPECIFIC STAMPED & SIGNED GFT CERTIFICATION LETTER

UNIRAC'S GFT
GROUND FIXED TILT
STRUCTURAL RACKING DRAWINGS

20 DEGREE UNIRAC STEEL C-PILE FOUNDATION DEPTHS (REFER TO SHEET SR-200 FOR PILE STICK-UP HEIGHT) (c)										
FOUNDATION TYPE	DETAIL NUMBER	NO FROST DEPTH			FROST DEPTH = 3.5 FT OR LESS			FROST DEPTH = 5.0 FT		
		DIMENSION "A"	DIMENSION "B"	DIMENSION "C"	DIMENSION "A"	DIMENSION "B"	DIMENSION "C"	DIMENSION "D"	DIMENSION "E"	DIMENSION "F"
FULL CAST IN-PLACE CONCRETE	400	6'-0" (a)	--	--	6'-0" (a)	--	--	8'-0"	--	--
CAST IN-PLACE CONCRETE	401	--	--	--	6'-0" (a)	--	--	8'-0"	--	--
PARTIAL DRIVEN PILE WITH FROST BREAK (b)	402	--	--	--	--	3'-6"	8'-0"	--	5'-0"	--
FULLY DRIVEN PILE (b)	403	--	--	8'-0"	--	--	8'-0"	--	--	10'-6"

(a) THIS 6'-0" EMBEDMENT REQUIRES CUTTING 24" OFF OF THE BOTTOM OF A 12'-6" LONG C-PILE. (DO NOT CUT THE END OF PILE WITH PRE-PUNCHED HOLES.) IF CUTTING IS NOT PREFERRED, AN 8'-0" CONCRETE FOUNDATION IS ACCEPTABLE.

(b) SHALLOWER EMBEDMENT DEPTHS ARE POSSIBLE, HOWEVER, PILE TESTING AND/OR APPROVAL FROM A GEOTECHNICAL OR PROFESSIONAL ENGINEER ARE REQUIRED.

(c) BASED ON THE PILE STICK-UP HEIGHT FOR A STANDARD 20 DEGREE GFT TABLE, ALL PILE EMBEDMENT DEPTHS THAT ARE 6'-1" OR GREATER, REQUIRE A 15 FT LONG PILE.

30 DEGREE UNIRAC STEEL C-PILE FOUNDATION DEPTHS (REFER TO SHEET SR-300 FOR PILE STICK-UP HEIGHT) (e)										
FOUNDATION TYPE	DETAIL NUMBER	NO FROST DEPTH			FROST DEPTH = 3.5 FT OR LESS			FROST DEPTH = 5.0 FT		
		DIMENSION "A"	DIMENSION "B"	DIMENSION "C"	DIMENSION "A"	DIMENSION "B"	DIMENSION "C"	DIMENSION "D"	DIMENSION "E"	DIMENSION "F"
FULL CAST IN-PLACE CONCRETE	400	6'-0"	--	--	6'-0"	--	--	6'-0"	--	--
CAST IN-PLACE CONCRETE	401	--	--	--	6'-0"	--	--	7'-6"	--	--
PARTIAL DRIVEN PILE WITH FROST BREAK (d)	402	--	--	--	--	3'-6"	8'-6"	--	5'-0"	--
FULLY DRIVEN PILE (d)	403	--	--	8'-6"	--	--	8'-6"	--	--	8'-6"

(d) SHALLOWER EMBEDMENT DEPTHS ARE POSSIBLE, HOWEVER, PILE TESTING AND/OR APPROVAL FROM A GEOTECHNICAL OR PROFESSIONAL ENGINEER ARE REQUIRED.

(e) BASED ON THE PILE STICK-UP HEIGHT FOR A STANDARD 30 DEGREE GFT TABLE, ALL PILE EMBEDMENT DEPTHS THAT ARE 6'-4" OR GREATER, REQUIRE A 15 FT LONG PILE.

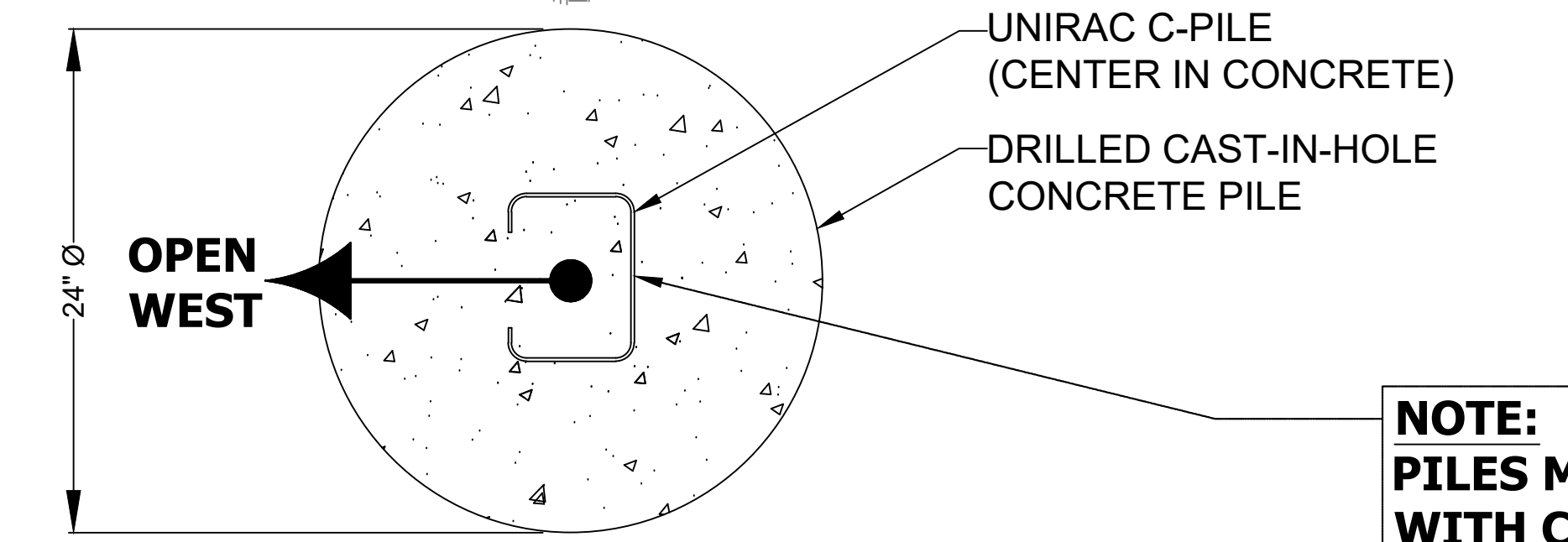
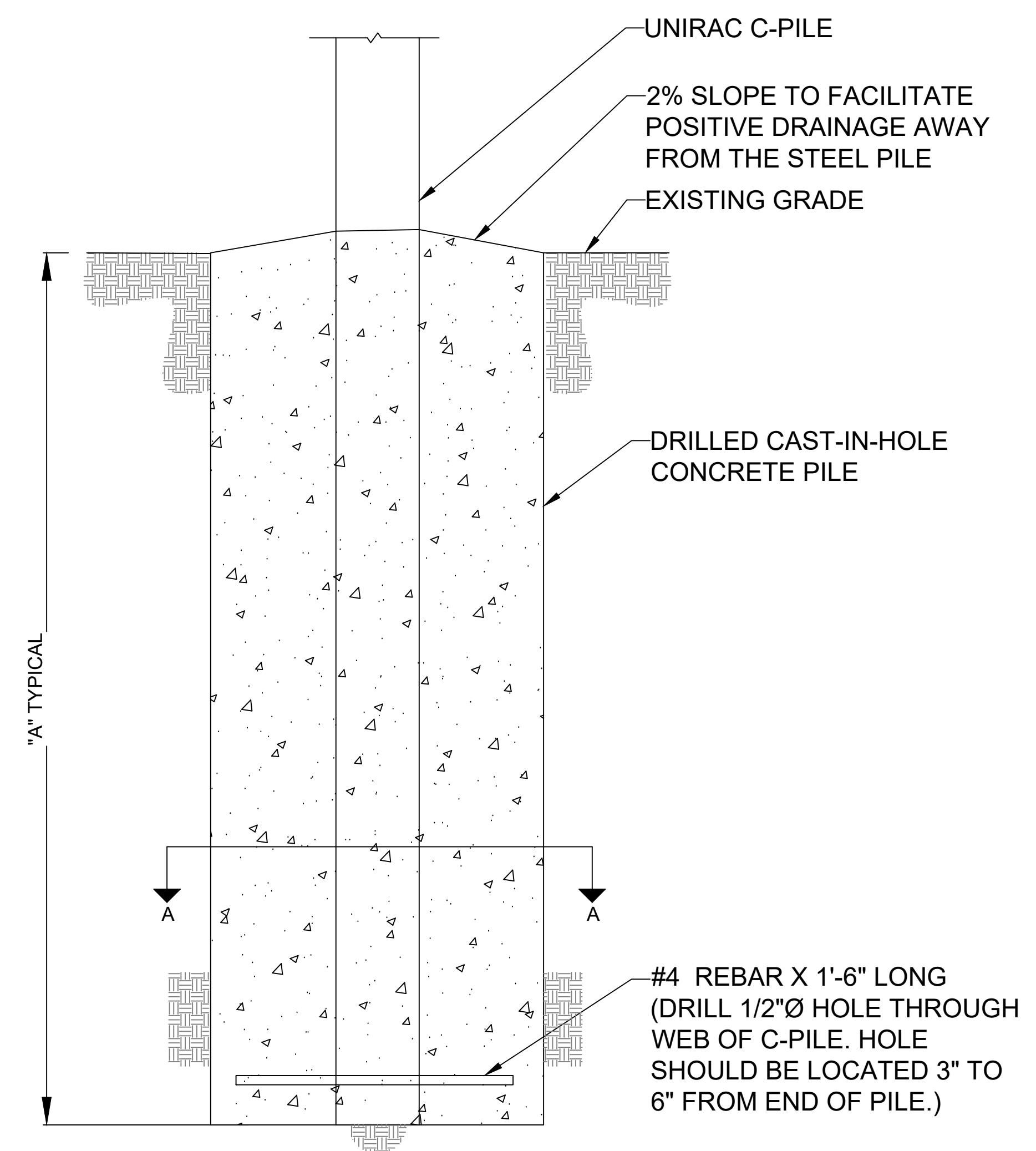

NOTE:
PILES MUST BE INSTALLED WITH C-PILE OPEN TO THE WEST - AS SHOWN

400

DRILLED CAST-IN-HOLE CONCRETE PILE FOUNDATION
(ALTERNATE OPTION)

NOT TO SCALE

- FOUNDATION 400: DRILLED CAST-IN-HOLE CONCRETE PILE FOUNDATION
1. THE FOUNDATION MUST BE EXCAVATED WITH LITTLE TO NO LOOSE MATERIAL IN THE BOTTOM.
 2. THE FOUNDATION CANNOT BE BELOW THE GROUND WATER UNLESS WRITTEN APPROVAL FROM UNIRAC.
 3. IN SOFT OR UNSTABLE SOILS, A TEMPORARY CASING TO STABILIZE THE EXCAVATION IS PERMITTED.
 4. THE PILE SHALL HAVE A #4 REBAR PLACED THROUGH THE BOTTOM OF THE PILE.
 5. THE PILE MUST BE CENTERED IN THE HOLE WITH EQUAL AMOUNTS OF CONCRETE AROUND THE CASING.
 6. CONCRETE SHALL CONFORM TO THE CONCRETE SPECIFICATIONS LISTED ON SR-100.
 7. CONCRETE DEPTH SHALL CONFORM TO THE DEPTHS LISTED IN THE TABLE ON THIS SHEET.
 8. THE TOP OF THE CONCRETE MUST BE ABOVE GRADE.
 9. THE CORE OF THE CONCRETE CAST-IN-DRILLED HOLE PILE WILL CONSIST OF THE UNIRAC C-PILES AS DEPICTED IN THE FIGURE.

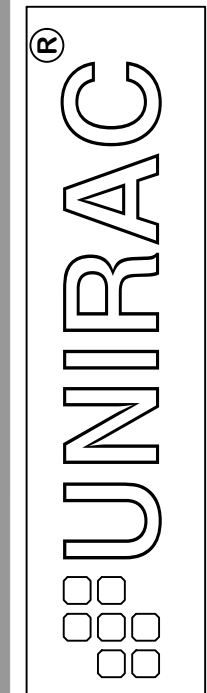

1411 Broadway Boulevard NE
Albuquerque, New Mexico 87102
Phone: (505) 242-6411
Fax: (505) 242-6412
www.unirac.com

ALL INFORMATION PROVIDED HEREIN IS CONFIDENTIAL AND PROPRIETARY AND IS SOLE PROPERTY OF UNIRAC, INC. REPRODUCTION AND DISTRIBUTION OF THIS DOCUMENT WITHOUT THE WRITTEN CONSENT OF UNIRAC, INC. WILL CONSTITUTE COPYRIGHT INFRINGEMENT UNDER U.S. LAW.

PROJECT NUMBER:	GFT
ENGINEERED BY:	JRS
DRAFTED BY:	JRS
REVIEWED BY:	EP
ORIGINAL RELEASE DATE:	08/14/2019
DRAWING SHEET SIZE:	D - 24x36

SHEET TITLE
FOUNDATION
EMBEDMENT AND
FOUNDATION DETAILS

SHEET NUMBER
SR-400
SHEET
6 of 11

20 DEGREE UNIRAC STEEL C-PILE FOUNDATION DEPTHS										
(REFER TO SHEET SR-200 FOR PILE STICK-UP HEIGHT) (c)										
FOUNDATION TYPE	DETAIL NUMBER	NO FROST DEPTH			FROST DEPTH = 3.5 FT OR LESS			FROST DEPTH = 5.0 FT		
		DIMENSION "A"	DIMENSION "B"	DIMENSION "C"	DIMENSION "A"	DIMENSION "B"	DIMENSION "C"	DIMENSION "D"	DIMENSION "E"	DIMENSION "F"
FULL CAST IN-PLACE CONCRETE	400	6'-0" (a)	--	--	6'-0" (a)	--	--	8'-0"	--	--
CAST IN-PLACE CONCRETE	401	--	--	--	6'-0" (a)	--	--	8'-0"	--	--
PARTIAL DRIVEN PILE WITH FROST BREAK (b)	402	--	--	--	--	3'-6"	8'-0"	--	5'-0"	--
FULLY DRIVEN PILE (b)	403	--	--	8'-0"	--	--	8'-0"	--	--	10'-6"

(a) THIS 6'-0" EMBEDMENT REQUIRES CUTTING 24" OFF OF THE BOTTOM OF A 12'-6" LONG C-PILE. (DO NOT CUT THE END OF PILE WITH PRE-PUNCHED HOLES.) IF CUTTING IS NOT PREFERRED, AN 8'-0" CONCRETE FOUNDATION IS ACCEPTABLE.

(b) SHALLOWER EMBEDMENT DEPTHS ARE POSSIBLE, HOWEVER, PILE TESTING AND/OR APPROVAL FROM A GEOTECHNICAL OR PROFESSIONAL ENGINEER ARE REQUIRED.

(c) BASED ON THE PILE STICK-UP HEIGHT FOR A STANDARD 20 DEGREE GFT TABLE, ALL PILE EMBEDMENT DEPTHS THAT ARE 8'-1" OR GREATER, REQUIRE A 15 FT LONG PILE.

NOTE:
PILES MUST BE INSTALLED WITH C-PILE OPEN TO THE WEST - AS SHOWN

30 DEGREE UNIRAC STEEL C-PILE FOUNDATION DEPTHS										
(REFER TO SHEET SR-300 FOR PILE STICK-UP HEIGHT) (e)										
FOUNDATION TYPE	DETAIL NUMBER	NO FROST DEPTH			FROST DEPTH = 3.5 FT OR LESS			FROST DEPTH = 5.0 FT		
		DIMENSION "A"	DIMENSION "B"	DIMENSION "C"	DIMENSION "A"	DIMENSION "B"	DIMENSION "C"	DIMENSION "D"	DIMENSION "E"	DIMENSION "F"
FULL CAST IN-PLACE CONCRETE	400	6'-0"	--	--	6'-0"	--	--	6'-0"	--	--
CAST IN-PLACE CONCRETE	401	--	--	--	6'-0"	--	--	7'-6"	--	--
PARTIAL DRIVEN PILE WITH FROST BREAK (d)	402	--	--	--	--	3'-6"	8'-6"	--	5'-0"	--
FULLY DRIVEN PILE (d)	403	--	--	8'-6"	--	--	8'-6"	--	--	8'-6"

(d) SHALLOWER EMBEDMENT DEPTHS ARE POSSIBLE, HOWEVER, PILE TESTING AND/OR APPROVAL FROM A GEOTECHNICAL OR PROFESSIONAL ENGINEER ARE REQUIRED.

(e) BASED ON THE PILE STICK-UP HEIGHT FOR A STANDARD 30 DEGREE GFT TABLE, ALL PILE EMBEDMENT DEPTHS THAT ARE 6'-4" OR GREATER, REQUIRE A 15 FT LONG PILE.

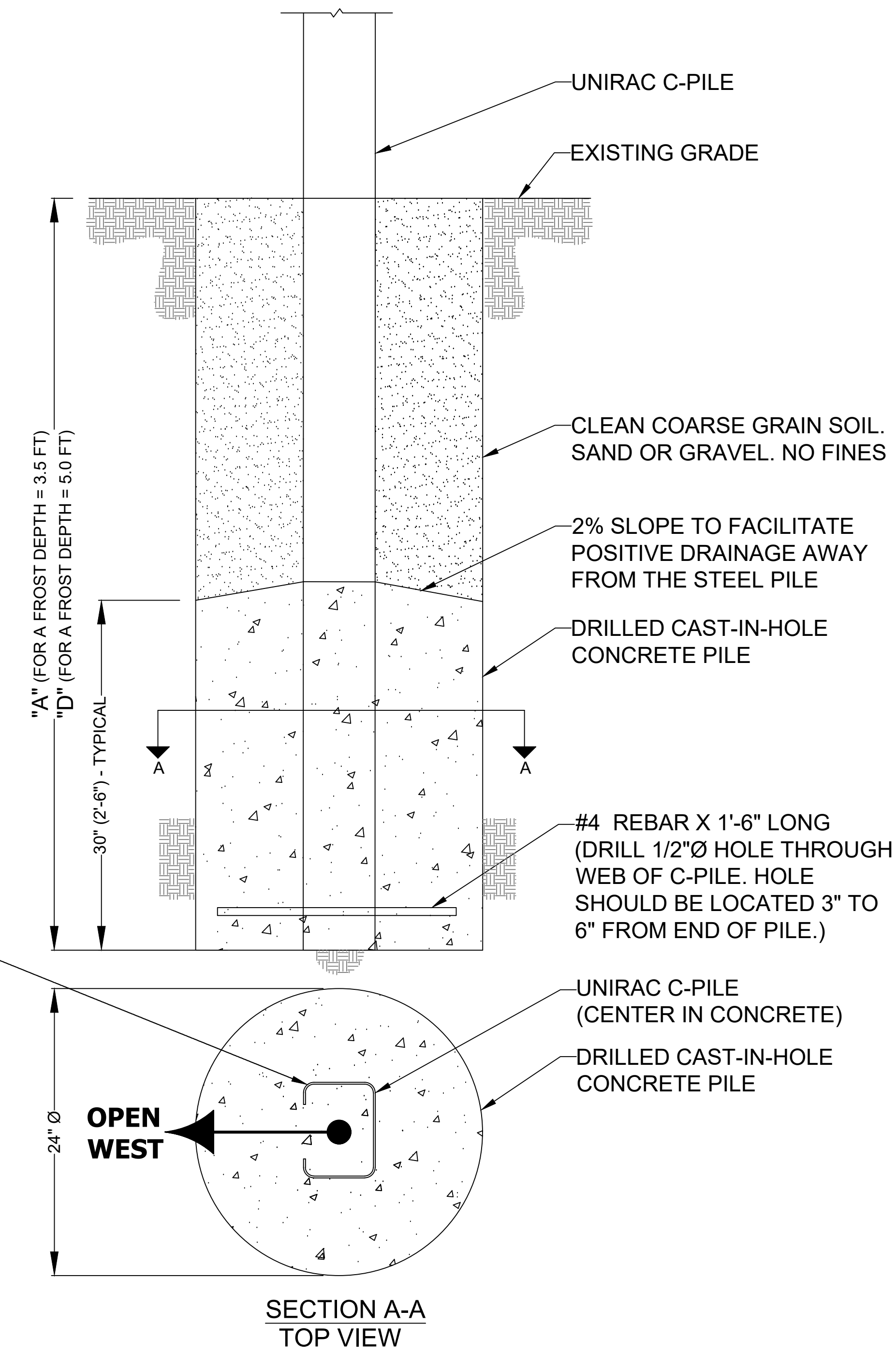

SECTION A-A TOP VIEW
DRILLED "PARTIAL" CAST-IN-HOLE CONCRETE PILE FOUNDATION
(ALTERNATE OPTION) NOT TO SCALE

401

- FOUNDATION 401: DRILLED "PARTIAL" CAST-IN-HOLE CONCRETE PILE FOUNDATION
1. THE FOUNDATION MUST BE EXCAVATED WITH LITTLE TO NO LOOSE MATERIAL IN THE BOTTOM.
 2. THE FOUNDATION CANNOT BE BELOW THE GROUND WATER UNLESS WRITTEN APPROVAL FROM UNIRAC.
 3. THE PILE SHALL HAVE A #4 REBAR PLACED THROUGH THE BOTTOM OF THE PILE.
 4. THE PILE MUST BE CENTERED IN THE HOLE WITH EQUAL AMOUNTS OF CONCRETE AROUND THE CASING.
 5. CONCRETE SHALL CONFORM TO THE CONCRETE SPECIFICATIONS LISTED ON SR-100.
 6. CONCRETE DEPTH SHALL CONFIRM TO THE DEPTHS LISTED IN THE TABLE ON THIS SHEET.
 7. THE TOP OF THE CONCRETE MUST BE BELOW THE DEPTH OF THE FROST ZONE.
 8. THE CORE OF THE CONCRETE CAST-IN-DRILLED HOLE PILE WILL CONSIST OF THE UNIRAC C-PILES AS DEPICTED IN THE FIGURE.
 9. THE BACKFILL MATERIAL MUST CONSIST OF MEDIUM TO COARSE SAND OR GRAVEL. NO CLAY OR ORGANICS MAY BE USED IN THE BACKFILL.
 10. FOUNDATIONS MUST NOT BE INSTALLED IN ORGANIC SOILS OR IN AREAS WITH GROUNDWATER NEAR THE SURFACE.

REVISION BLOCK		
MARK	DATE	DESCRIPTION
0	08/14/2019	Original Release
1	08/22/2019	Rev-1
2	03/30/2020	Rev-2

OWNER/CLIENT:

ENGINEERING CONSULTANT:

PROFESSIONAL SEAL

SEE STATE SPECIFIC STAMPED & SIGNED GFT CERTIFICATION LETTER

UNIRAC'S GFT
GROUND FIXED TILT
STRUCTURAL RACKING DRAWINGS

UNIRAC®
1411 Broadway Boulevard NE
Albuquerque, New Mexico 87102
Phone: (505) 242-6411
Fax: (505) 242-6412
www.unirac.com

ALL INFORMATION PROVIDED HEREIN IS CONFIDENTIAL AND PROPRIETARY AND IS SOLE PROPERTY OF UNIRAC, INC. REPRODUCTION, DISTRIBUTION, OR DISSEMINATION OF THIS INFORMATION WITHOUT THE WRITTEN CONSENT OF UNIRAC, INC. WILL CONSTITUTE COPYRIGHT INFRINGEMENT UNDER U.S. LAW.

PROJECT NUMBER: GFT
ENGINEERED BY: JRS
DRAFTED BY: JRS
REVIEWED BY: EP
ORIGINAL RELEASE DATE: 08/14/2019
DRAWING SHEET SIZE: D - 24x36

SHEET TITLE
ADDITIONAL
FOUNDATION DETAILS

SHEET NUMBER
SR-401
SHEET
7 of 11

REVISION BLOCK		
MARK	DATE	DESCRIPTION
0	08/14/2019	Original Release
1	08/22/2019	Rev-1
2	03/30/2020	Rev-2

OWNER/CLIENT:

ENGINEERING CONSULTANT:

PROFESSIONAL SEAL

SEE STATE SPECIFIC STAMPED & SIGNED GFT CERTIFICATION LETTER

UNIRAC'S GFT
 GROUND FIXED TILT
 STRUCTURAL RACKING DRAWINGS

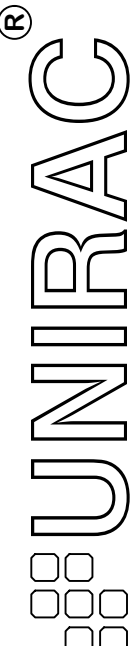

1411 Broadway Boulevard NE
 Albuquerque, New Mexico 87102
 Phone: (505) 242-6411
 Fax: (505) 242-6412
 www.unirac.com

ALL INFORMATION PROVIDED HEREIN IS CONFIDENTIAL AND PROPRIETARY AND IS SOLE PROPERTY OF UNIRAC, INC. REPRODUCTION, DISTRIBUTION, OR DISSEMINATION OF THIS INFORMATION WITHOUT THE WRITTEN PERMISSION OF UNIRAC, INC. WILL CONSTITUTE COPYRIGHT INFRINGEMENT UNDER U.S. LAW.

PROJECT NUMBER:	GFT
ENGINEERED BY:	JRS
DRAFTED BY:	JRS
REVIEWED BY:	EP
ORIGINAL RELEASE DATE:	08/14/2019
DRAWING SHEET SIZE:	D - 24x36

SHEET TITLE
 ADDITIONAL FOUNDATION DETAILS

SHEET NUMBER
SR-402 SHEET
 8 of 11

20 DEGREE UNIRAC STEEL C-PILE FOUNDATION DEPTHS										
(REFER TO SHEET SR-200 FOR PILE STICK-UP HEIGHT) (c)										
FOUNDATION TYPE	DETAIL NUMBER	NO FROST DEPTH			FROST DEPTH = 3.5 FT OR LESS			FROST DEPTH = 5.0 FT		
		DIMENSION "A"	DIMENSION "B"	DIMENSION "C"	DIMENSION "A"	DIMENSION "B"	DIMENSION "C"	DIMENSION "D"	DIMENSION "E"	DIMENSION "F"
FULL CAST IN-PLACE CONCRETE	400	6'-0" (a)	--	--	6'-0" (a)	--	--	8'-0"	--	--
CAST IN-PLACE CONCRETE	401	--	--	--	6'-0" (a)	--	--	8'-0"	--	--
PARTIAL DRIVEN PILE WITH FROST BREAK (b)	402	--	--	--	--	3'-6"	8'-0"	--	5'-0"	--
FULLY DRIVEN PILE (b)	403	--	--	8'-0"	--	--	8'-0"	--	--	10'-6"

(a) THIS 6'-0" EMBEDMENT REQUIRES CUTTING 24" OFF OF THE BOTTOM OF A 12'-6" LONG C-PILE. (DO NOT CUT THE END OF PILE WITH PRE-PUNCHED HOLES.) IF CUTTING IS NOT PREFERRED, AN 8'-0" CONCRETE FOUNDATION IS ACCEPTABLE.

(b) SHALLOWER EMBEDMENT DEPTHS ARE POSSIBLE, HOWEVER, PILE TESTING AND/OR APPROVAL FROM A GEOTECHNICAL OR PROFESSIONAL ENGINEER ARE REQUIRED.

(c) BASED ON THE PILE STICK-UP HEIGHT FOR A STANDARD 20 DEGREE GFT TABLE, ALL PILE EMBEDMENT DEPTHS THAT ARE 8'-1" OR GREATER, REQUIRE A 15 FT LONG PILE.

30 DEGREE UNIRAC STEEL C-PILE FOUNDATION DEPTHS										
(REFER TO SHEET SR-300 FOR PILE STICK-UP HEIGHT) (e)										
FOUNDATION TYPE	DETAIL NUMBER	NO FROST DEPTH			FROST DEPTH = 3.5 FT OR LESS			FROST DEPTH = 5.0 FT		
		DIMENSION "A"	DIMENSION "B"	DIMENSION "C"	DIMENSION "A"	DIMENSION "B"	DIMENSION "C"	DIMENSION "D"	DIMENSION "E"	DIMENSION "F"
FULL CAST IN-PLACE CONCRETE	400	6'-0"	--	--	6'-0"	--	--	6'-0"	--	--
CAST IN-PLACE CONCRETE	401	--	--	--	6'-0"	--	--	7'-6"	--	--
PARTIAL DRIVEN PILE WITH FROST BREAK (d)	402	--	--	--	--	3'-6"	8'-6"	--	5'-0"	--
FULLY DRIVEN PILE (d)	403	--	--	8'-6"	--	--	8'-6"	--	--	8'-6"

(d) SHALLOWER EMBEDMENT DEPTHS ARE POSSIBLE, HOWEVER, PILE TESTING AND/OR APPROVAL FROM A GEOTECHNICAL OR PROFESSIONAL ENGINEER ARE REQUIRED.

(e) BASED ON THE PILE STICK-UP HEIGHT FOR A STANDARD 30 DEGREE GFT TABLE, ALL PILE EMBEDMENT DEPTHS THAT ARE 6'-4" OR GREATER, REQUIRE A 15 FT LONG PILE.

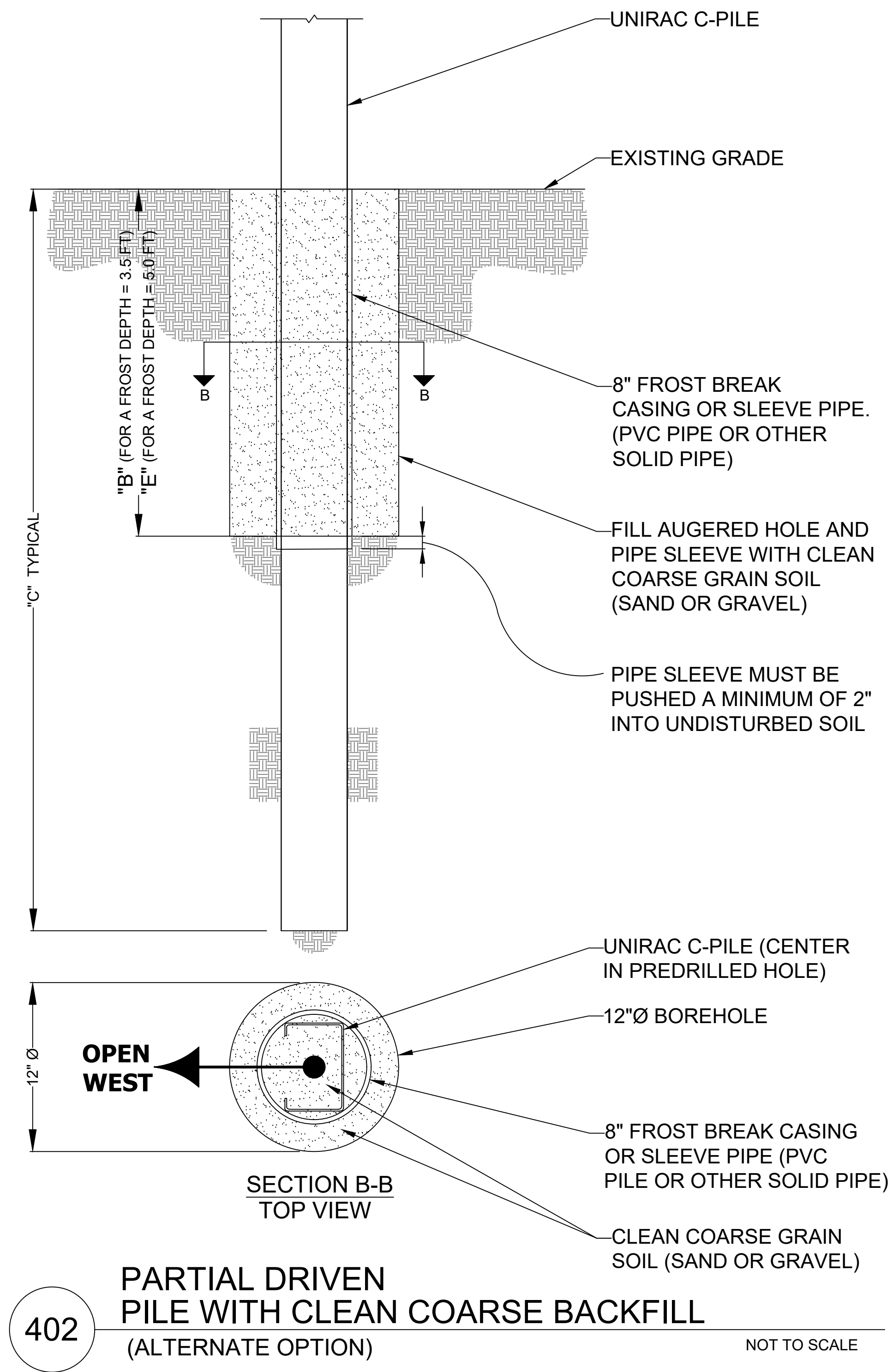

402 PARTIAL DRIVEN PILE WITH CLEAN COARSE BACKFILL (ALTERNATE OPTION) NOT TO SCALE

- FOUNDATION 402: PARTIAL DRIVEN PILE WITH CLEAN COARSE BACKFILL.
1. EACH PILE LOCATION MUST BE EXCAVATED TO A MINIMUM OF THE DIMENSION SHOWN.
 2. THE PILE MUST BE CENTERED IN THE HOLE WITH THE FROST BREAK CASING PLACED AROUND THE PILE PRIOR TO BACKFILLING THE EXCAVATION.
 3. THE FROST BREAK CASING MUST NOT HAVE ANY CRACKS OR HOLES THAT MAY ALLOW WATER TO SEEP IN. THE CASING MUST BE SET A MINIMUM OF 2 INCHES INTO THE NATIVE SOIL IN THE BOTTOM OF THE EXCAVATION. THE CASING TOP MUST EXTEND TO THE GROUND SURFACE.
 4. THE FILL MATERIAL MUST CONSIST OF SAND OR GRAVEL WITH LESS THAN 5 PERCENT SILT CONTENT. NO CLAY OR ORGANICS MAY BE USED IN THE BACKFILL MATERIAL.
 5. THE PILE MUST BE INSTALLED TO THE FULL DEPTH INDICATED. PILES NOT DRIVEN TO THE FULL DEPTH ARE CONSIDERED FAILED AND THE CONCRETE OPTION MUST BE UTILIZED.
 6. THE CASING MUST BE FILLED WITH THE SAME FILL MATERIAL AFTER THE PILE IS INSTALLED TO THE CORRECT DEPTH.
 7. THE FILL SHALL BE FORMED TO DIRECT WATER AWAY FROM THE FOUNDATION.
 8. IF THE CASING IS AFFECTED BY FROST HEAVE, THE CASING SHALL BE ATTEMPTED TO BE RE-EMBEDDED TO THE PROPER DEPTH IN ORDER TO PROTECT THE C-PILE FROM FUTURE FROST HEAVE.
 9. FOUNDATIONS MUST NOT BE INSTALLED IN ORGANIC SOILS OR IN AREAS WITH GROUNDWATER NEAR THE SURFACE.

REVISION BLOCK		
MARK	DATE	DESCRIPTION
0	08/14/2019	Original Release
1	08/22/2019	Rev-1
2	03/30/2020	Rev-2

OWNER/CLIENT:

ENGINEERING CONSULTANT:

PROFESSIONAL SEAL

SEE STATE SPECIFIC STAMPED & SIGNED GFT CERTIFICATION LETTER

UNIRAC'S GFT
 GROUND FIXED TILT
 STRUCTURAL RACKING DRAWINGS

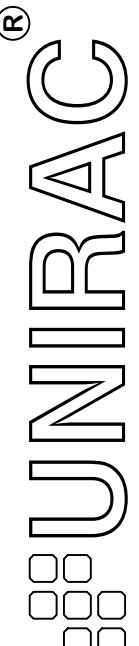

1411 Broadway Boulevard NE
 Albuquerque, New Mexico 87102
 Phone: (505) 242-6411
 Fax: (505) 242-6412
 www.unirac.com

ALL INFORMATION PROVIDED HEREIN IS CONFIDENTIAL AND PROPRIETARY AND IS SOLE PROPERTY OF UNIRAC, INC. REPRODUCTION AND DISTRIBUTION OF THIS DOCUMENT WITHOUT THE WRITTEN AND AUTHORIZED PERMISSION OF UNIRAC, INC. WILL CONSTITUTE COPYRIGHT INFRINGEMENT UNDER U.S. LAW.

PROJECT NUMBER:	GFT
ENGINEERED BY:	JRS
DRAFTED BY:	JRS
REVIEWED BY:	EP
ORIGINAL RELEASE DATE:	08/14/2019
DRAWING SHEET SIZE:	D - 24x36

SHEET TITLE
 FOUNDATION
 EMBEDMENT AND
 FOUNDATION DETAILS

20 DEGREE UNIRAC STEEL C-PILE FOUNDATION DEPTHS

(REFER TO SHEET SR-200 FOR PILE STICK-UP HEIGHT) (c)

FOUNDATION TYPE	DETAIL NUMBER	NO FROST DEPTH			FROST DEPTH = 3.5 FT OR LESS			FROST DEPTH = 5.0 FT		
		DIMENSION "A"	DIMENSION "B"	DIMENSION "C"	DIMENSION "A"	DIMENSION "B"	DIMENSION "C"	DIMENSION "D"	DIMENSION "E"	DIMENSION "F"
FULL CAST IN-PLACE CONCRETE	400	6'-0" (a)	--	--	6'-0" (a)	--	--	8'-0"	--	--
CAST IN-PLACE CONCRETE	401	--	--	--	6'-0" (a)	--	--	8'-0"	--	--
PARTIAL DRIVEN PILE WITH FROST BREAK (b)	402	--	--	--	--	3'-6"	8'-0"	--	5'-0"	--
FULLY DRIVEN PILE (b)	403	--	--	8'-0"	--	--	8'-0"	--	--	10'-6"

(a) THIS 6'-0" EMBEDMENT REQUIRES CUTTING 24" OFF OF THE BOTTOM OF A 12'-6" LONG C-PILE. (DO NOT CUT THE END OF PILE WITH PRE-PUNCHED HOLES.) IF CUTTING IS NOT PREFERRED, AN 8'-0" CONCRETE FOUNDATION IS ACCEPTABLE.

(b) SHALLOWER EMBEDMENT DEPTHS ARE POSSIBLE, HOWEVER, PILE TESTING AND/OR APPROVAL FROM A GEOTECHNICAL OR PROFESSIONAL ENGINEER ARE REQUIRED.

(c) BASED ON THE PILE STICK-UP HEIGHT FOR A STANDARD 20 DEGREE GFT TABLE, ALL PILE EMBEDMENT DEPTHS THAT ARE 8'-1" OR GREATER, REQUIRE A 15 FT LONG PILE.

30 DEGREE UNIRAC STEEL C-PILE FOUNDATION DEPTHS

(REFER TO SHEET SR-300 FOR PILE STICK-UP HEIGHT) (e)

FOUNDATION TYPE	DETAIL NUMBER	NO FROST DEPTH			FROST DEPTH = 3.5 FT OR LESS			FROST DEPTH = 5.0 FT		
		DIMENSION "A"	DIMENSION "B"	DIMENSION "C"	DIMENSION "A"	DIMENSION "B"	DIMENSION "C"	DIMENSION "D"	DIMENSION "E"	DIMENSION "F"
FULL CAST IN-PLACE CONCRETE	400	6'-0"	--	--	6'-0"	--	--	6'-0"	--	--
CAST IN-PLACE CONCRETE	401	--	--	--	6'-0"	--	--	7'-6"	--	--
PARTIAL DRIVEN PILE WITH FROST BREAK (d)	402	--	--	--	--	3'-6"	8'-6"	--	5'-0"	--
FULLY DRIVEN PILE (d)	403	--	--	8'-6"	--	--	8'-6"	--	--	8'-6"

(d) SHALLOWER EMBEDMENT DEPTHS ARE POSSIBLE, HOWEVER, PILE TESTING AND/OR APPROVAL FROM A GEOTECHNICAL OR PROFESSIONAL ENGINEER ARE REQUIRED.

(e) BASED ON THE PILE STICK-UP HEIGHT FOR A STANDARD 30 DEGREE GFT TABLE, ALL PILE EMBEDMENT DEPTHS THAT ARE 6'-4" OR GREATER, REQUIRE A 15 FT LONG PILE.

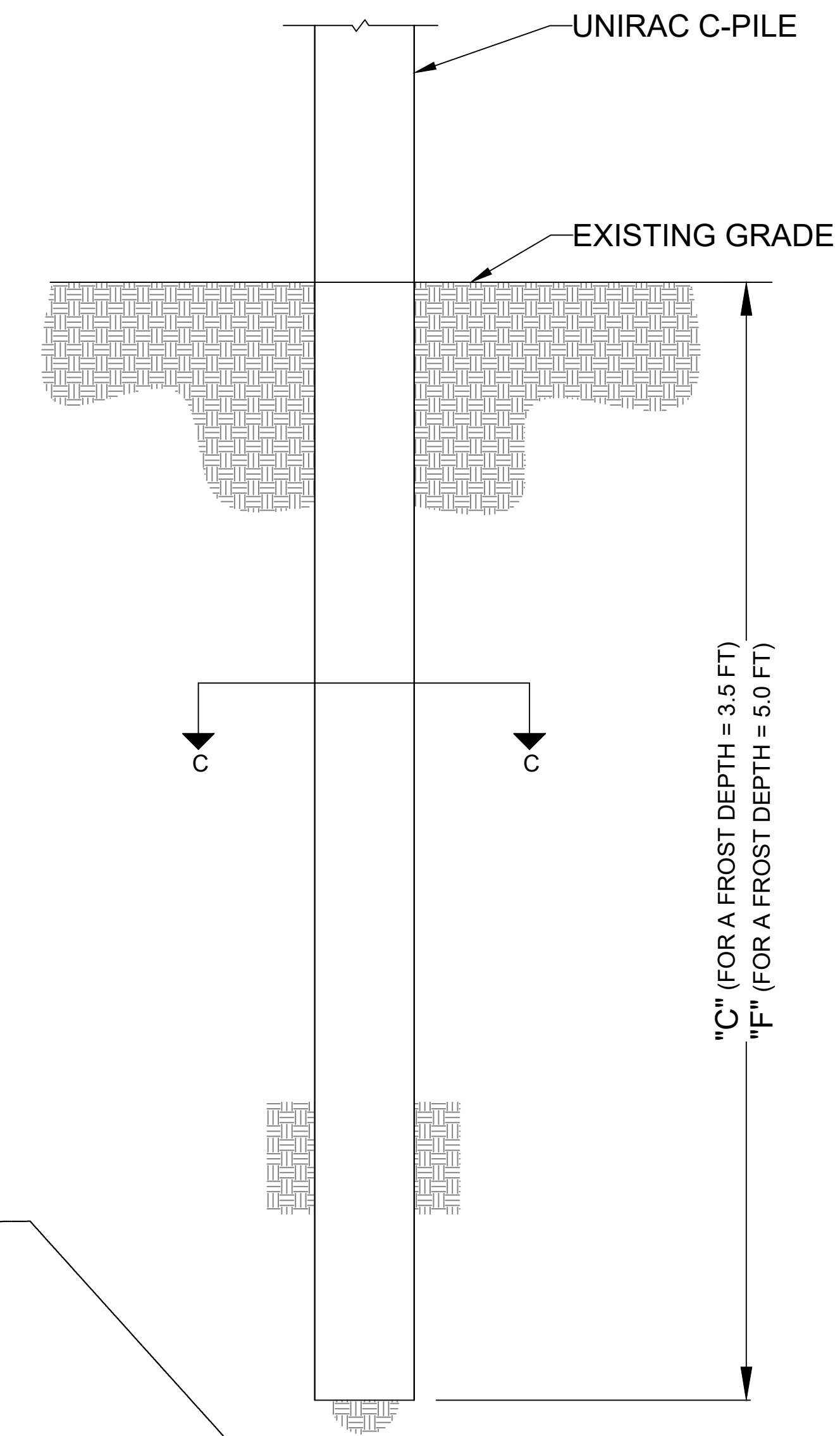

NOTE:
 PILES MUST BE INSTALLED WITH C-PILE OPEN TO THE WEST - AS SHOWN

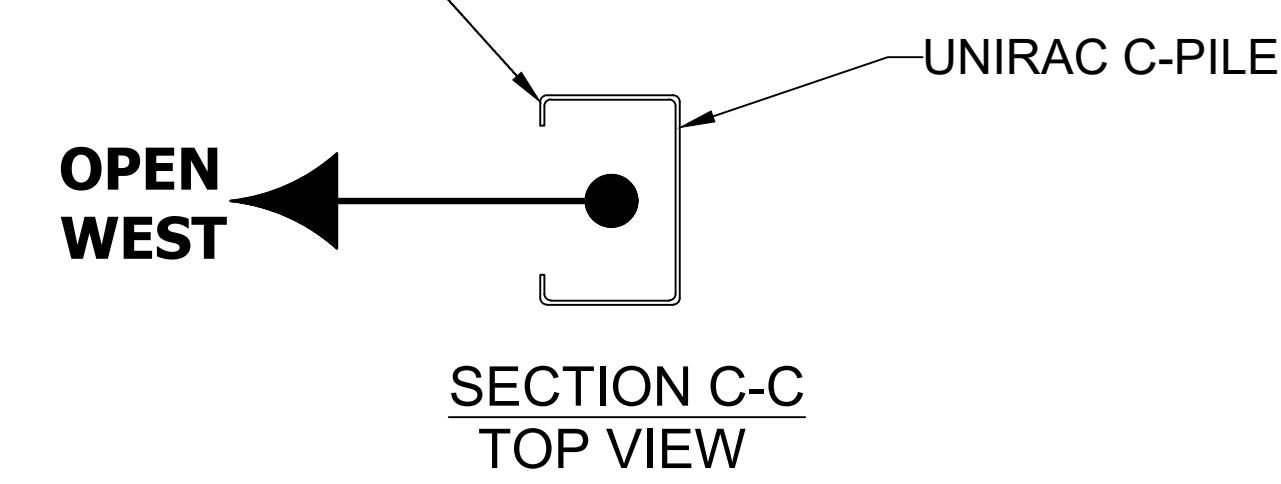

403 FULLY DRIVEN PILE (ALTERNATE OPTION) NOT TO SCALE

- FOUNDATION 403: FULLY DRIVEN PILE
- DRIVEN PILE FOUNDATIONS MAY NOT BE USED IN SOILS THAT CONTAIN SILT OR CLAY WITH GROUNDWATER WITHIN 12 FEET OF THE SURFACE UNLESS APPROVED BY A GEOTECHNICAL ENGINEER. IT IS RECOMMENDED TO VERIFY GROUNDWATER IS NOT PRESENT IF USING THIS FOUNDATION TYPE IN FROST PRONE REGIONS.
 - PILES MUST BE INSTALLED TO THE FULL DEPTH. PILES NOT DRIVEN TO FULL DEPTH ARE CONSIDERED FAILED PILES AND A DIFFERENT FOUNDATION MUST BE UTILIZED.
 - FOUNDATIONS MUST NOT BE INSTALLED IN ORGANIC SOILS OR IN AREAS WITH GROUNDWATER NEAR THE SURFACE.
 - PILE EMBEDMENT MUST BE DETERMINED BY A LICENSED CIVIL ENGINEER OR BY SITE PILE TESTS.

NOTE:
PILES MUST BE INSTALLED WITH C-PILE OPEN TO THE WEST - AS SHOWN

NOTE:
MAINTENANCE REQUIRED WHERE C-PILE ENTERS THE CONCRETE BLOCK. CAULKING OR NON-SHRINK GROUT WILL HELP TO PREVENT MOISTURE FROM ENTERING THIS VOID (THUS AVOIDING CORROSION AND FREEZE-THAW BREAKDOWN.)

NOTE:
PRECAST BLOCK OPTION WILL REQUIRE AN 8" SQUARE LEAVE-OUT AREA FOR THE C-PILE TO BE INSTALLED IN THE FIELD. HIGH STRENGTH GROUT REQUIRED TO SET C-PILE.

NOTE:
FOR PILE QUANTITY AND SPACING (BASED ON TABLE SIZE), SEE TABLES BOM.

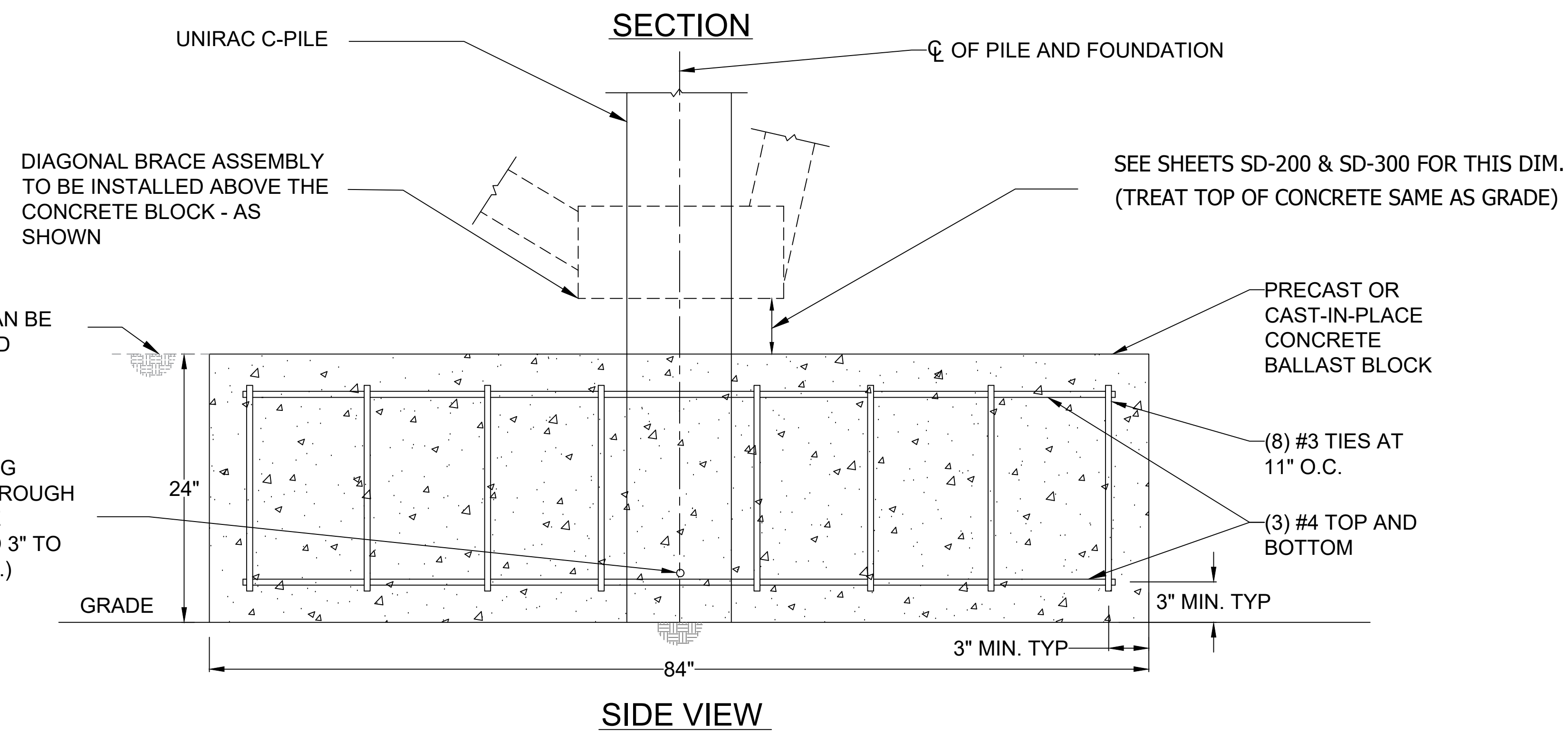
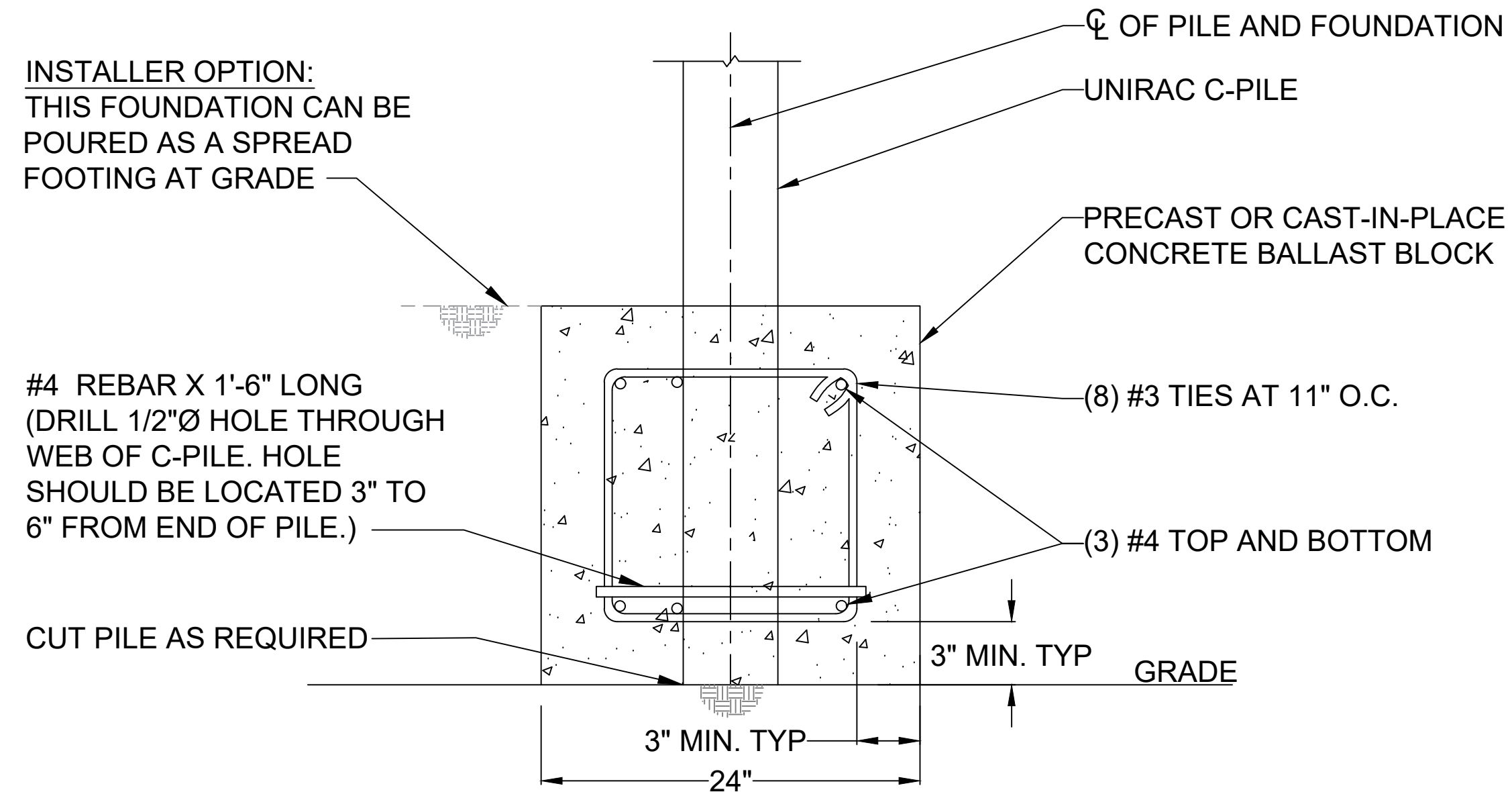

404

CONCRETE BALLAST OR SPREAD FOOTING (PRECAST OR CAST-IN-PLACE)
(ALTERNATE FOUNDATION OPTION) NOT TO SCALE

1. EXISTING GRADE MAY BE CLEARED/GRADED OR LEFT AS-IS. BLOCK DIMENSIONS SHOWN ABOVE ARE MINIMUM REQUIREMENTS.
2. THE PILE SHALL HAVE A #4 REBAR PLACED THROUGH THE BOTTOM OF THE PILE.
3. CONCRETE SHALL CONFORM TO THE CONCRETE SPECIFICATIONS LISTED ON SR-100.
4. UTILIZING THIS OPTION WILL RESULT IN AN INCREASED FRONT EDGE HEIGHT.
 - 4.1. 20 DEGREE TABLES: WILL NOW HAVE A FRONT EDGE HEIGHT OF APPROX. 4 FT ABOVE GRADE.
 - 4.2. 30 DEGREE TABLES: WILL NOW HAVE A FRONT EDGE HEIGHT OF APPROX. 4.5 FT ABOVE GRADE.
5. UNIRAC AND THE ENGINEER OF RECORD ARE NOT RESPONSIBLE FOR DIFFERENTIAL SETTLEMENT OR DIFFERENTIAL FROST HEAVE FROM ONE PILE FOUNDATION TO THE NEXT. PERIODIC MONITORING OF THE INSTALLED PILES AND CONCRETE FOUNDATION IS RECOMMENDED.

REVISION BLOCK		
MARK	DATE	DESCRIPTION
0	08/14/2019	Original Release
1	08/22/2019	Rev-1
2	03/30/2020	Rev-2

OWNER/CLIENT:

ENGINEERING CONSULTANT:

PROFESSIONAL SEAL

SEE STATE SPECIFIC STAMPED & SIGNED GFT CERTIFICATION LETTER

UNIRAC'S GFT
GROUND FIXED TILT
STRUCTURAL RACKING DRAWINGS

UNIRAC
1411 Broadway Boulevard NE
Albuquerque, New Mexico 87102
Phone: (505) 242-6411
Fax: (505) 242-6412
www.unirac.com

ALL INFORMATION PROVIDED HEREIN IS CONFIDENTIAL AND PROPRIETARY AND IS SOLE PROPERTY OF UNIRAC, INC. REPRODUCTION AND TRANSMISSION IN ANY FORM OR BY ANY MEANS WITHOUT THE WRITTEN PERMISSION OF UNIRAC, INC. WILL CONSTITUTE COPYRIGHT INFRINGEMENT UNDER U.S. LAW.

PROJECT NUMBER:	GFT
ENGINEERED BY:	JRS
DRAFTED BY:	JRS
REVIEWED BY:	EP
ORIGINAL RELEASE DATE:	08/14/2019
DRAWING SHEET SIZE:	D - 24x36

SHEET TITLE
FOUNDATION
EMBEDMENT AND
FOUNDATION DETAILS

SHEET NUMBER
SR-404 SHEET
10 of 11

RACKING DETAIL NOTES:

1. SEE INSTALLATION GUIDE FOR PILE TOLERANCES
2. SEE INSTALLATION GUIDE FOR CONNECTION ADJUSTMENT INSTRUCTIONS
3. SEE INSTALLATION GUIDE FOR INSTRUCTIONS TO INSTALL EAST/WEST BEAM SPLICE
4. DETAILS SEEN ON THIS SHEET ARE NOT DRAWN TO SCALE

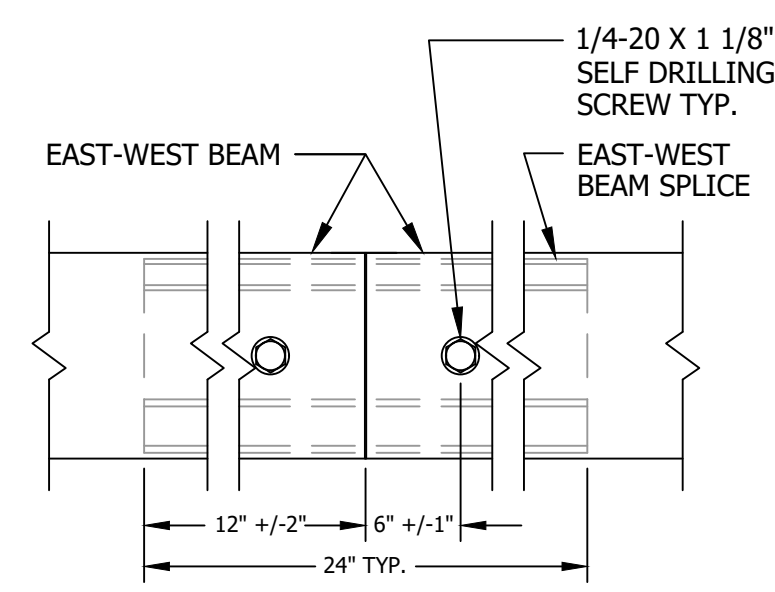
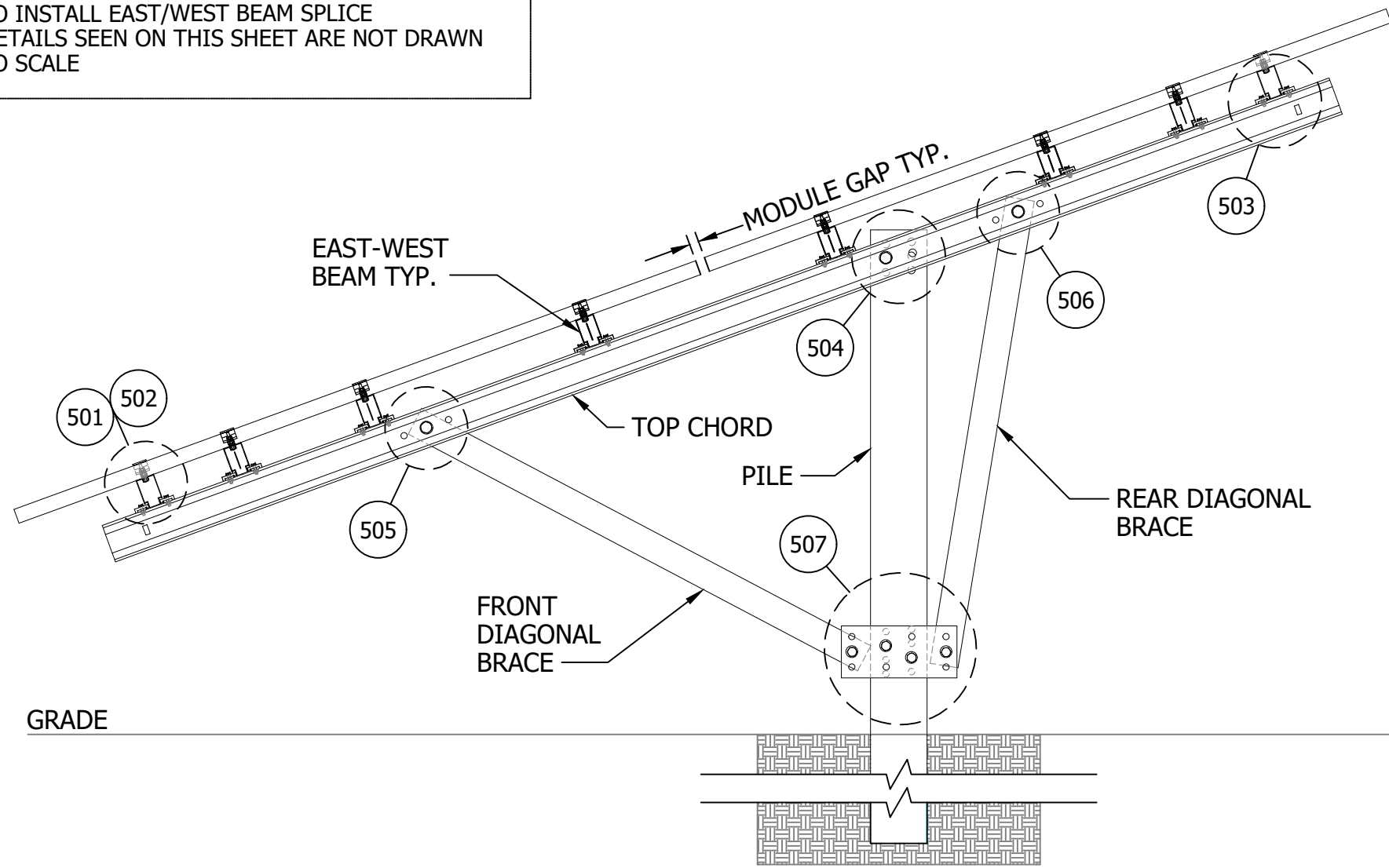

EAST-WEST BEAM WITH SPLICE
(TYPICAL ELEVATION)

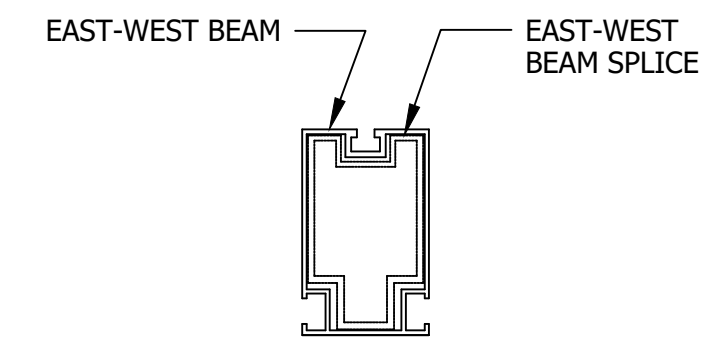

EAST-WEST BEAM WITH SPLICE
(TYPICAL SECTION)

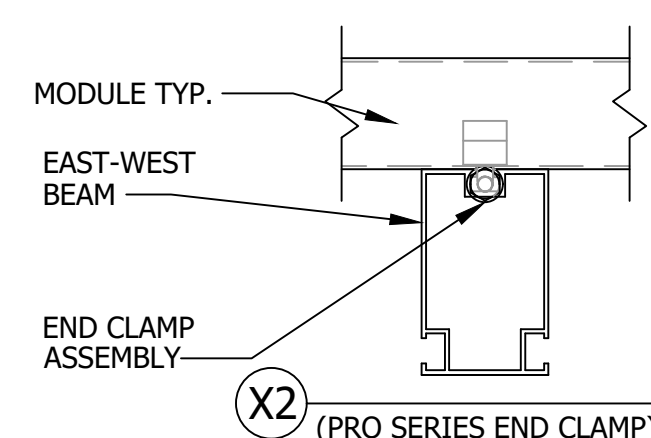
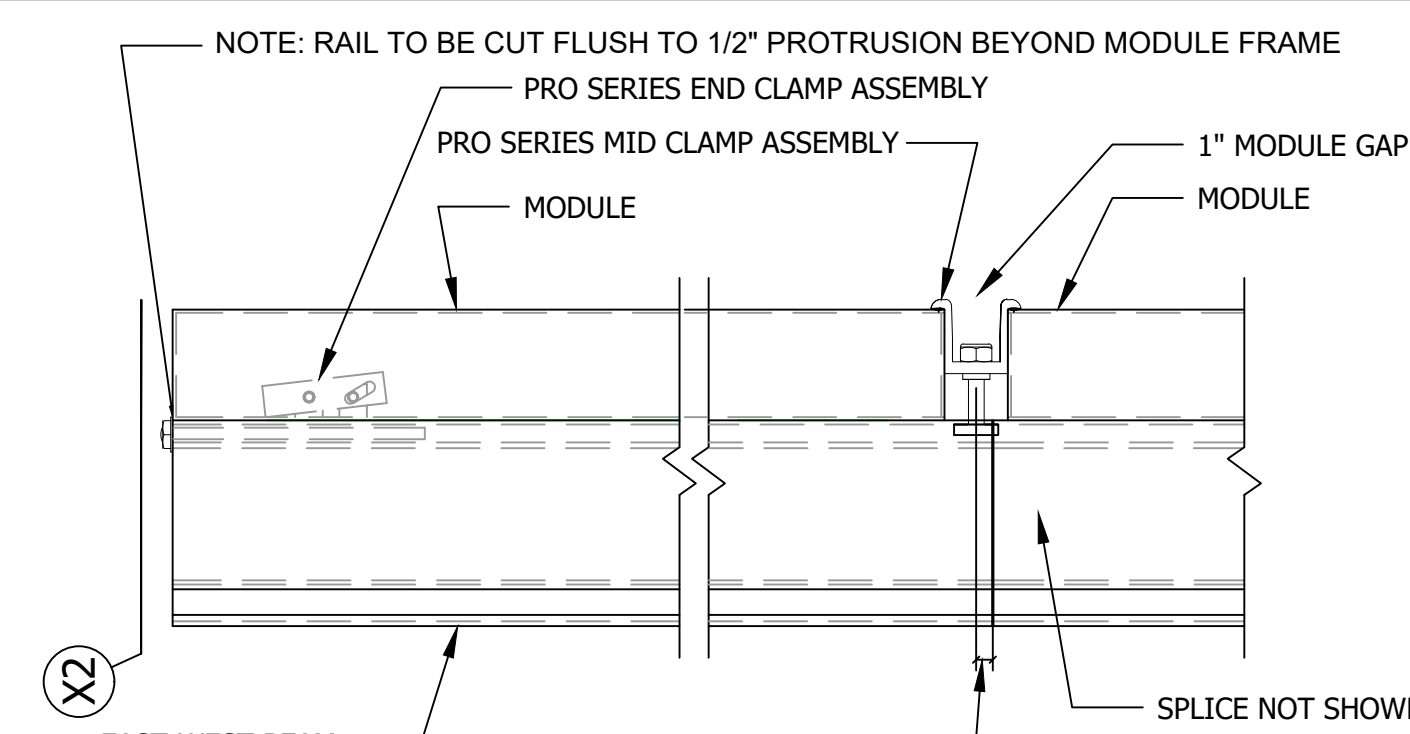

MODULE TO EAST-WEST BEAM END CLAMP CONNECTION
(PRO SERIES END CLAMP)

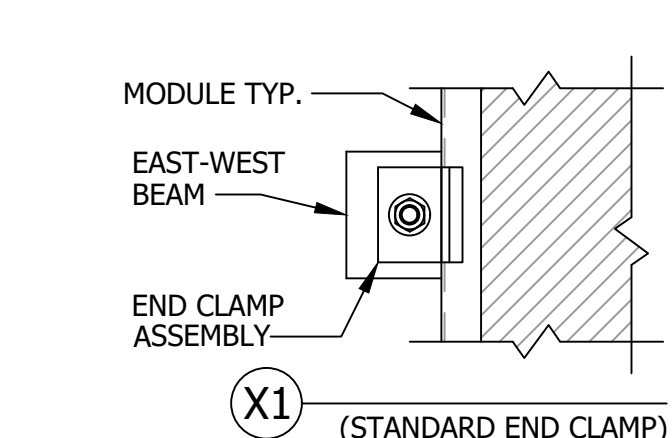
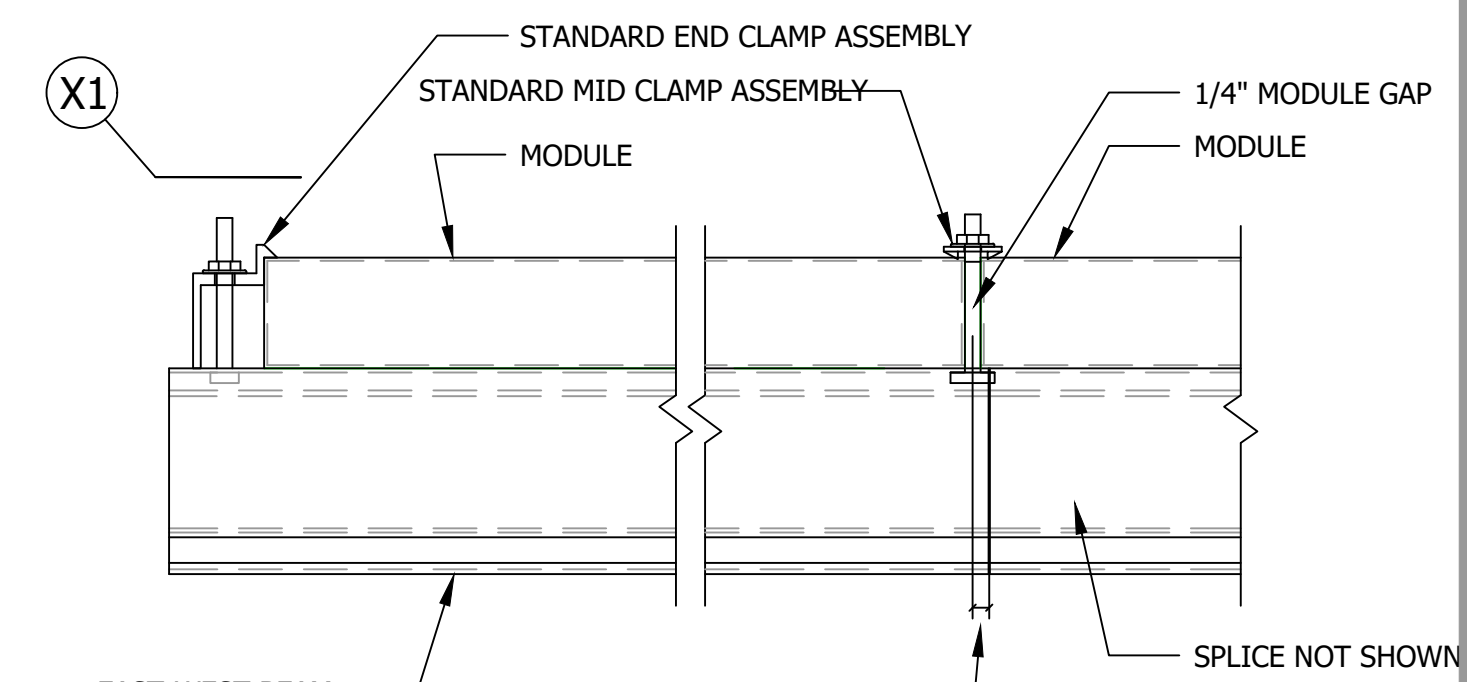

MODULE TO EAST-WEST BEAM END CLAMP CONNECTION
(STANDARD END CLAMP)

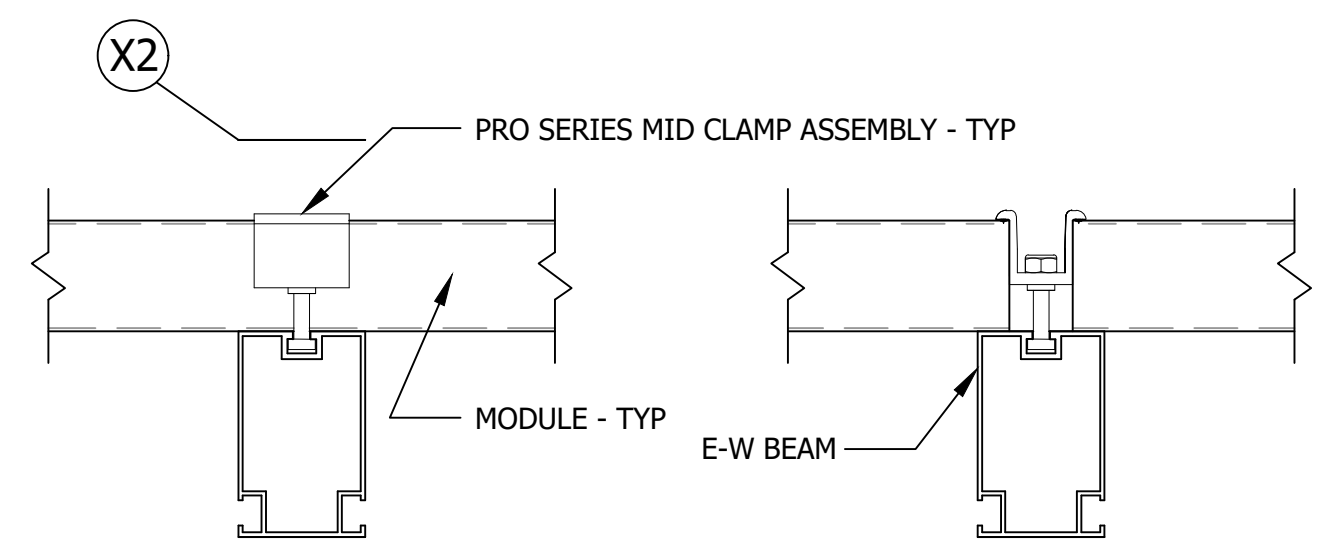

MODULE LONG SIDE CLAMPING
(UPPER & LOWER RAIL) **MODULE SHORT SIDE CLAMPING**
(CENTER SHARED RAIL)

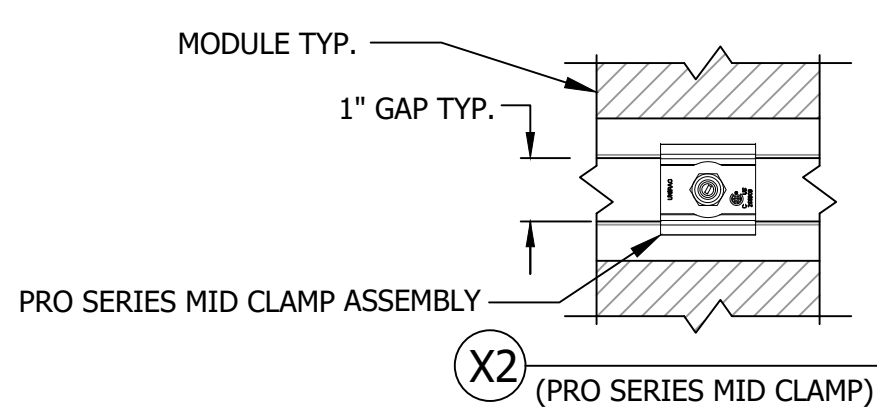

MODULE TO EAST-WEST BEAM MID CLAMP CONNECTION
(PRO SERIES MID CLAMP)

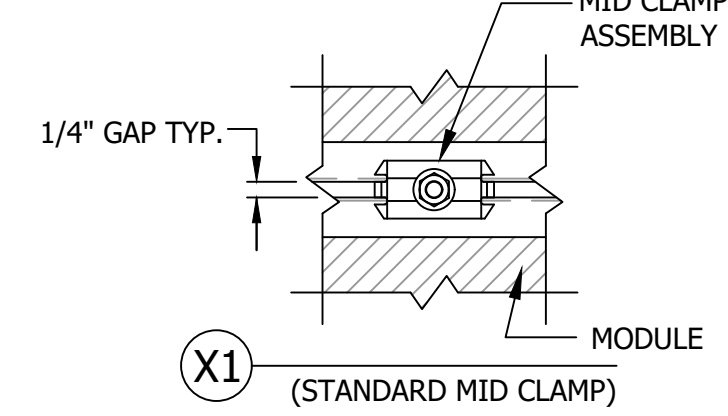
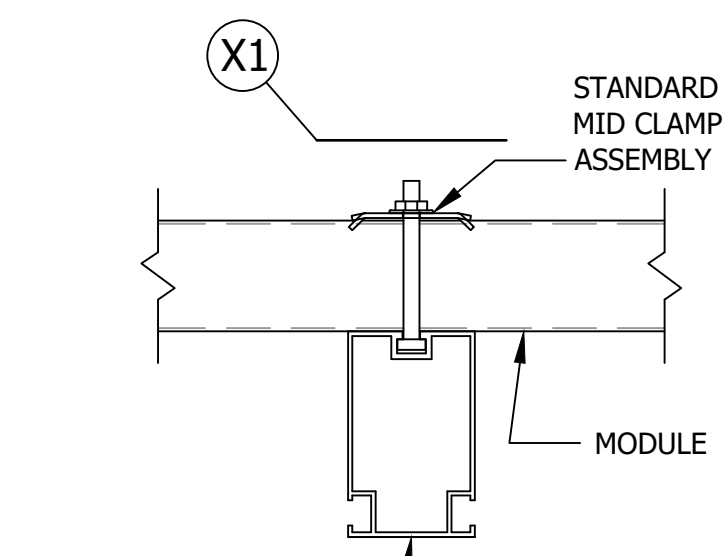

MODULE TO EAST-WEST BEAM MID CLAMP CONNECTION
(STANDARD MID CLAMP)

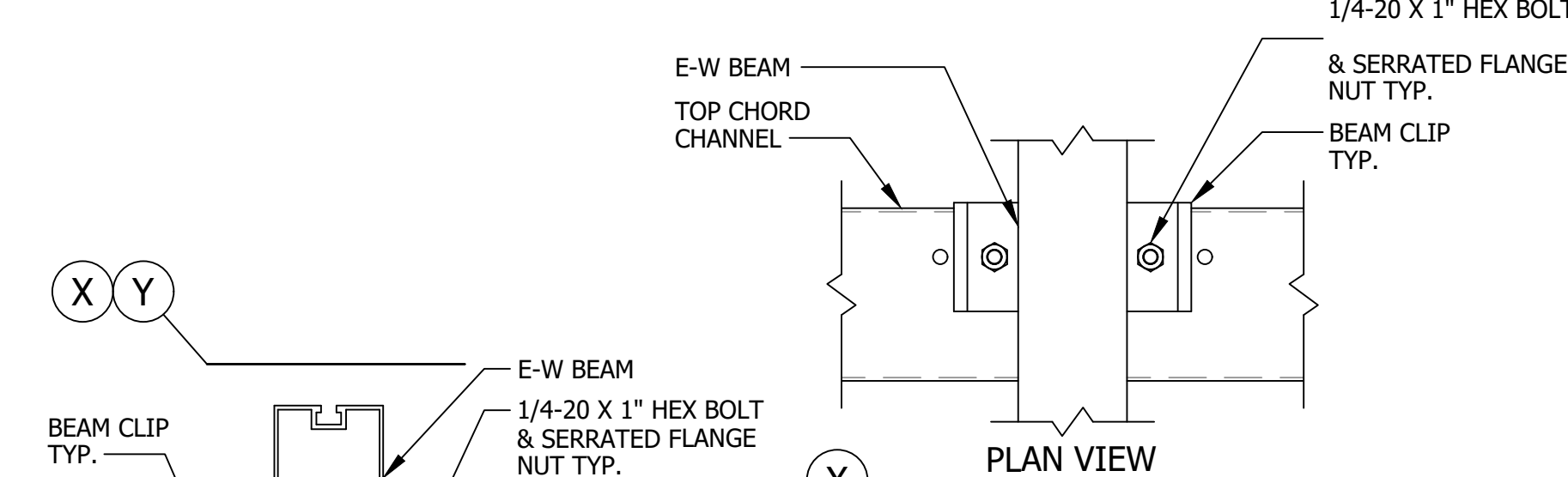

EAST-WEST BEAM TO TOP CHORD CONNECTION
(PLAN VIEW)

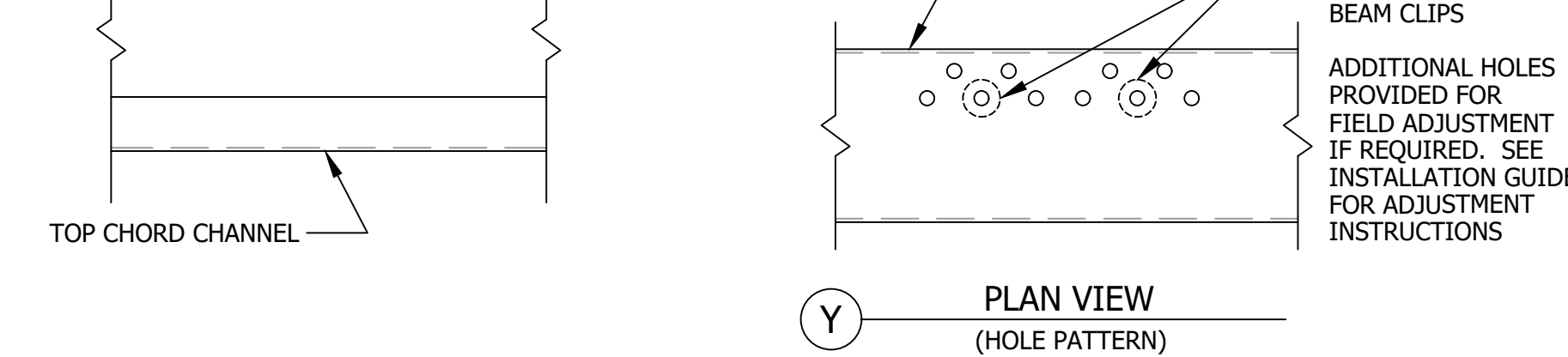

EAST-WEST BEAM TO TOP CHORD CONNECTION
(HOLE PATTERN)

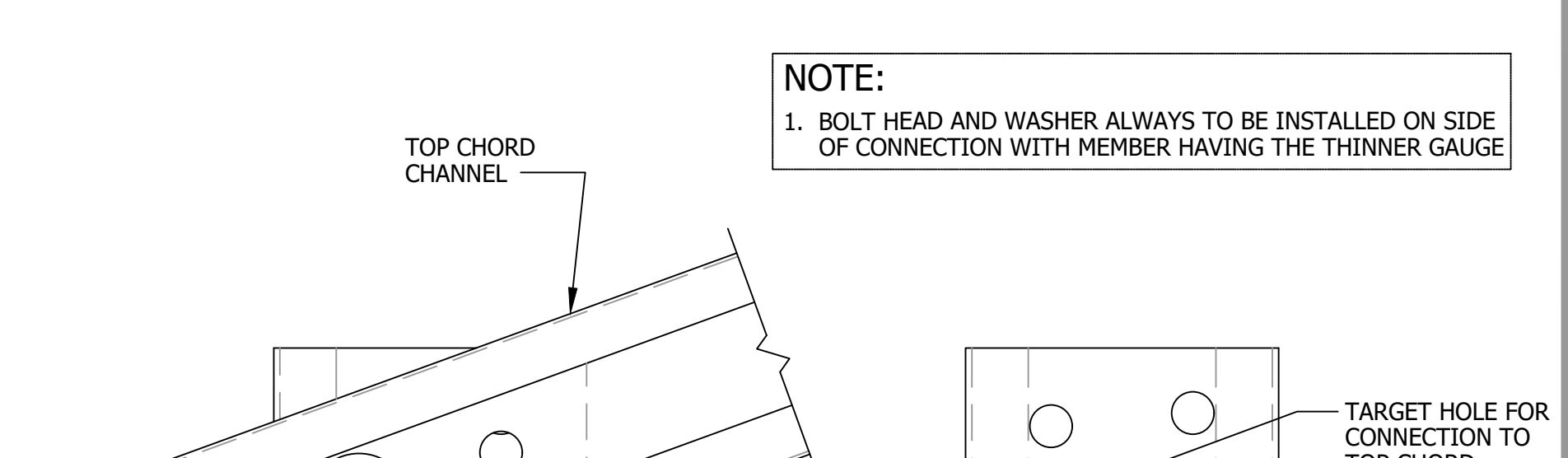

TOP CHORD TO PILE CONNECTION

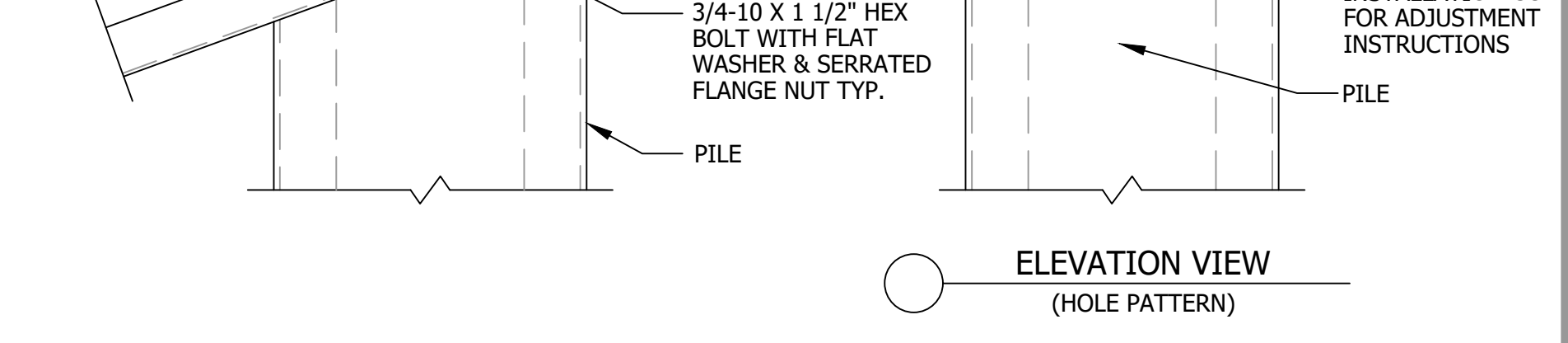

TOP CHORD TO PILE CONNECTION
(HOLE PATTERN)

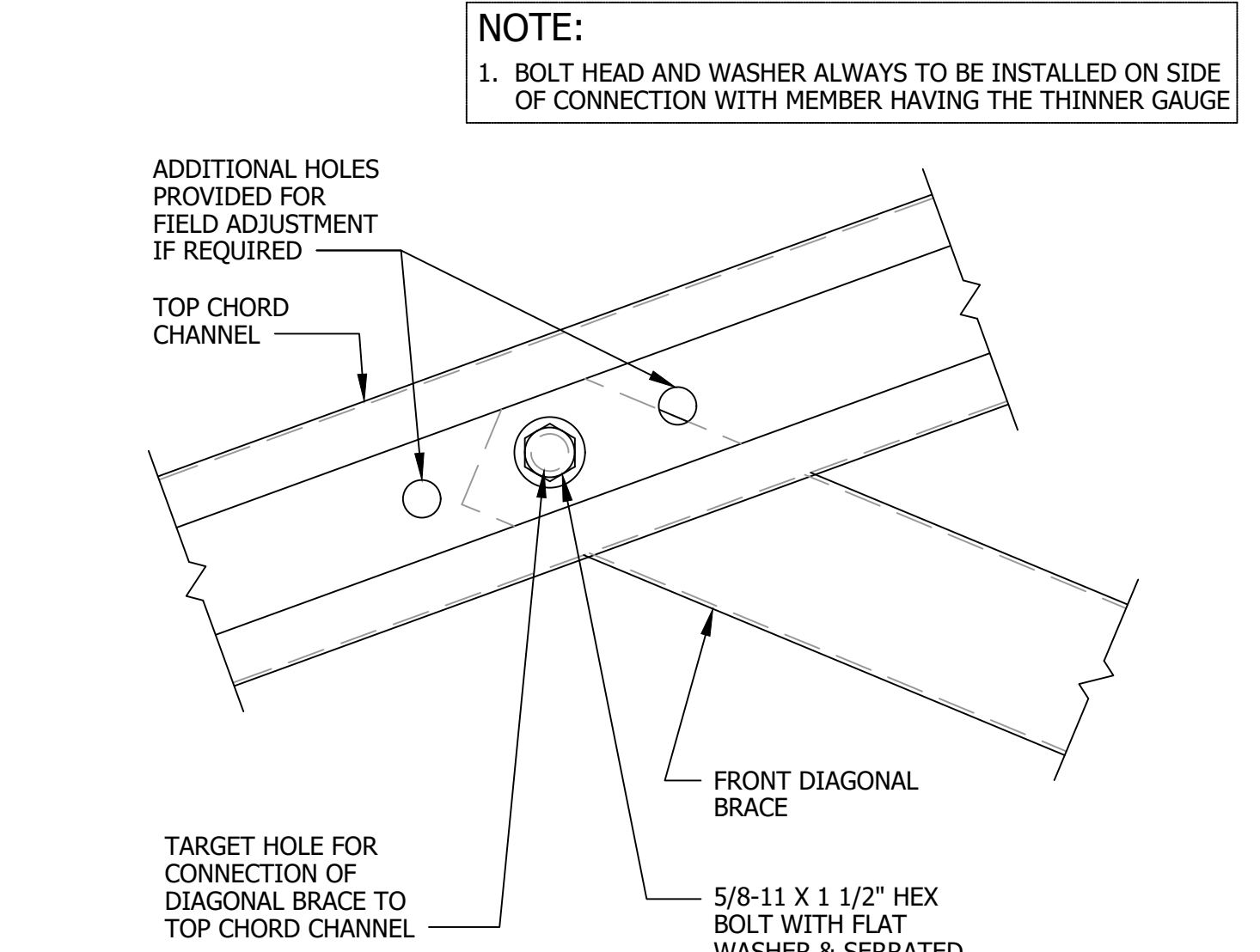

TOP CHORD TO DIAGONAL BRACE CONNECTION
(FRONT BRACE)

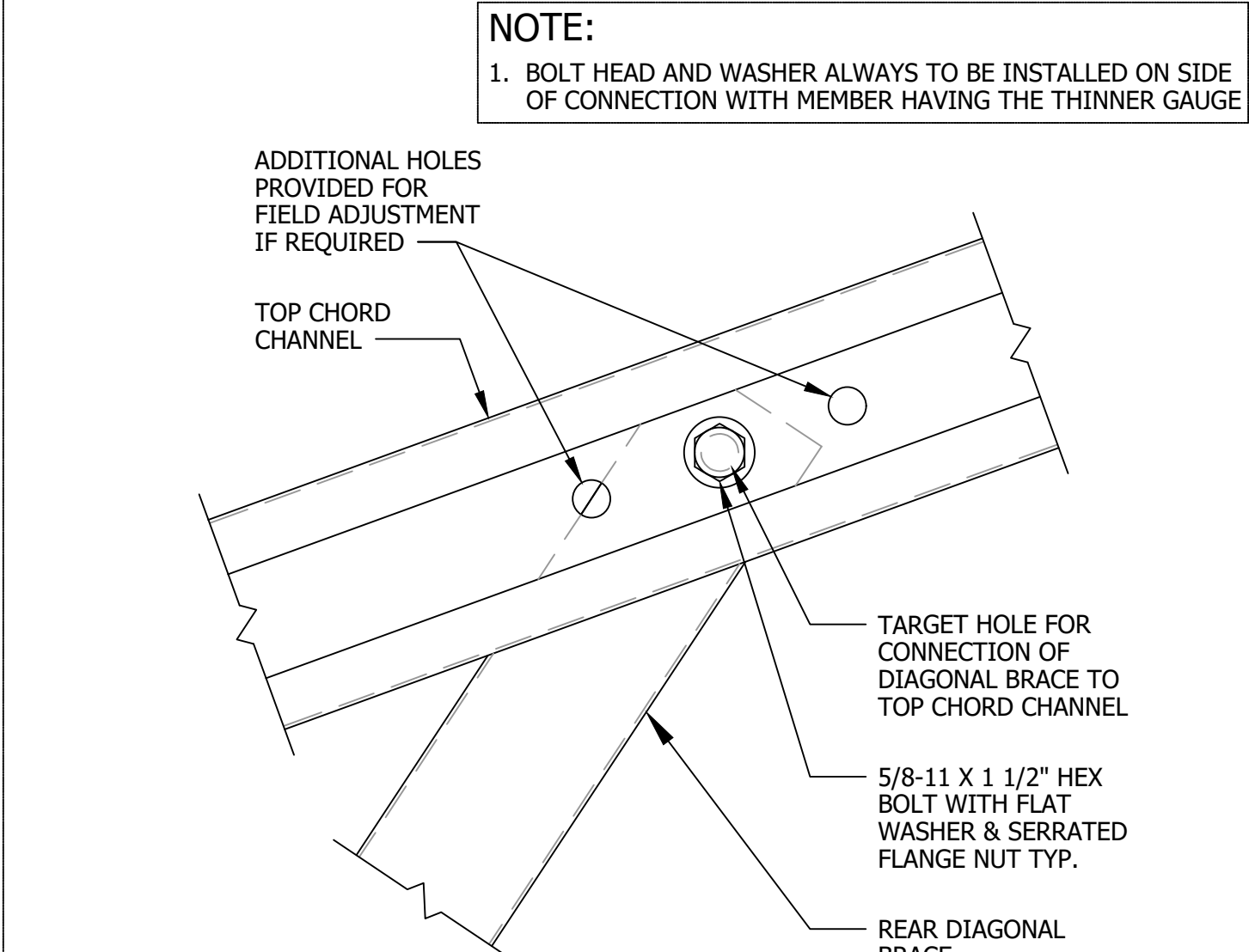

TOP CHORD TO DIAGONAL BRACE CONNECTION
(REAR BRACE)

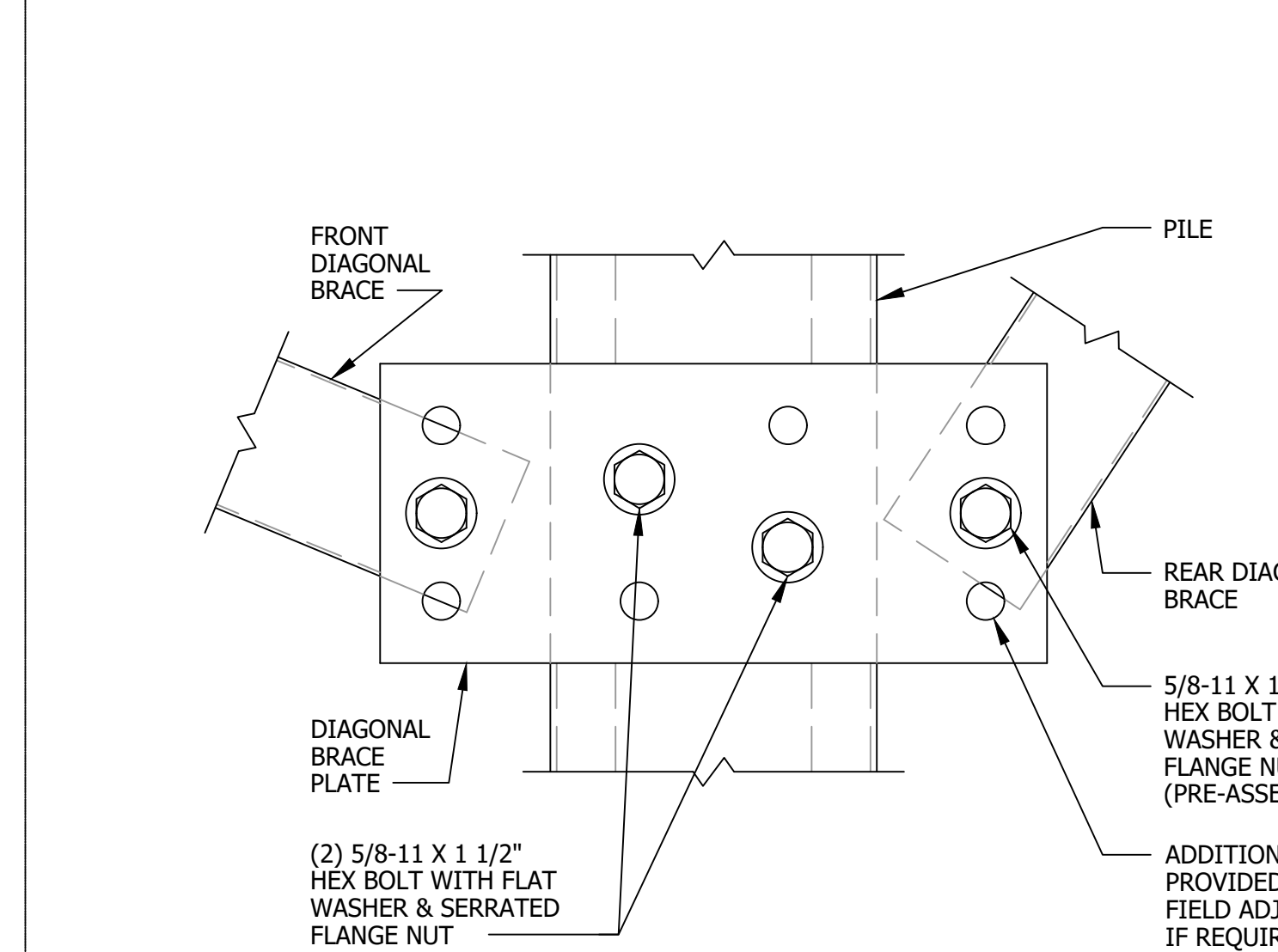

DIAGONAL BRACE TO PILE CONNECTION

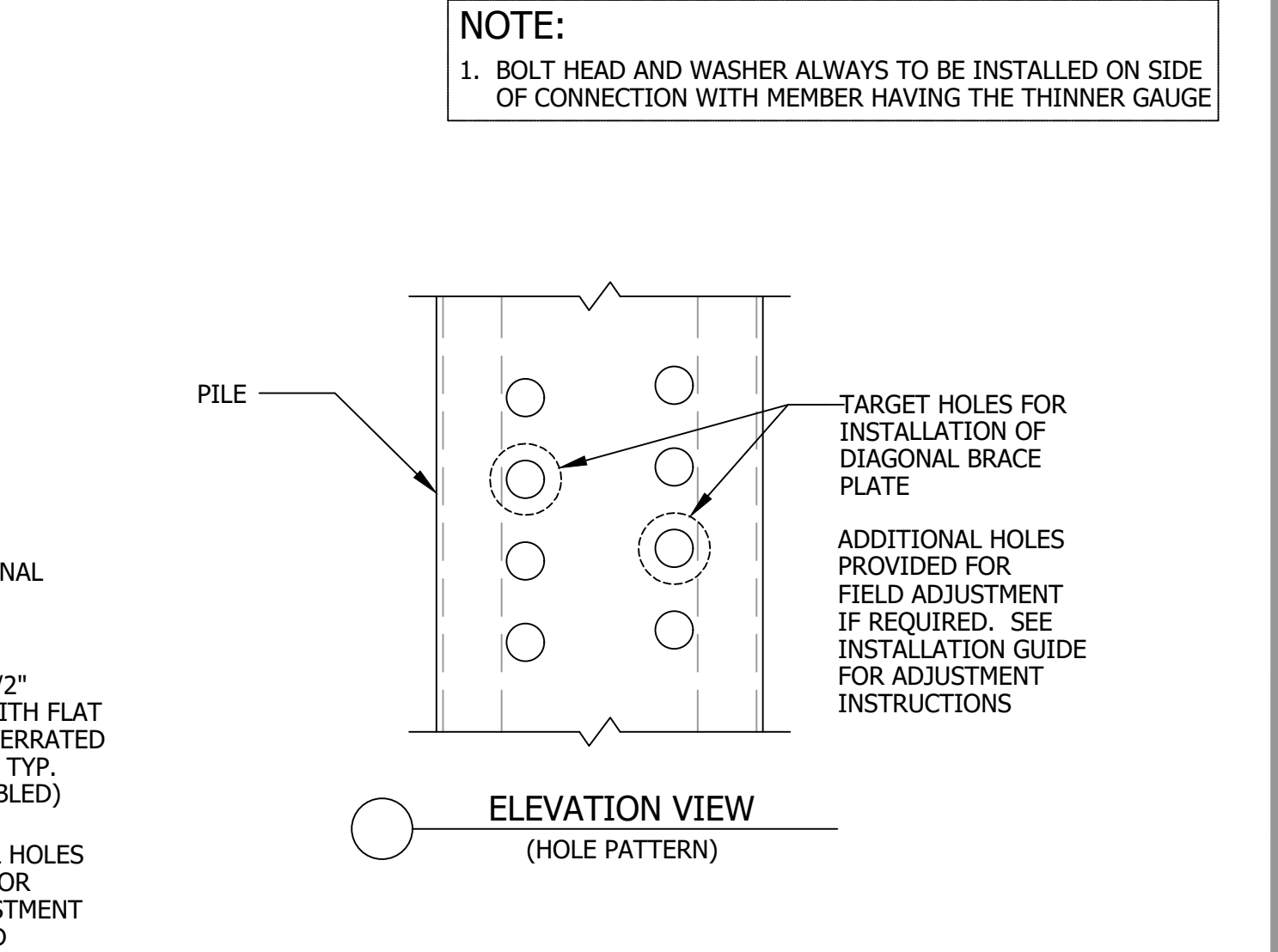

DIAGONAL BRACE TO PILE CONNECTION
(HOLE PATTERN)

REVISION BLOCK		
MARK	DATE	DESCRIPTION
0	08/14/2019	Original Release
1	08/22/2019	Rev-1
2	03/30/2020	Rev-2

OWNER/CLIENT:

ENGINEERING CONSULTANT:

PROFESSIONAL SEAL

SEE STATE SPECIFIC STAMPED & SIGNED GFT CERTIFICATION LETTER

UNIRAC'S GFT
GROUND FIXED TILT
STRUCTURAL RACKING DRAWINGS

UNIRAC
 1411 Broadway Boulevard NE
 Albuquerque, New Mexico 87102
 Phone: (505) 242-6411
 Fax: (505) 242-6412
 www.unirac.com

ALL INFORMATION PROVIDED HEREIN IS CONFIDENTIAL AND PROPRIETARY AND IS SOLE PROPERTY OF UNIRAC, INC. REPRODUCTION AND/OR TRANSMISSION IN ANY FORM OR BY ANY MEANS, WITHOUT THE WRITTEN PERMISSION OF UNIRAC, INC. WILL CONSTITUTE COPYRIGHT INFRINGEMENT UNDER U.S. LAW.

PROJECT NUMBER:	GFT
ENGINEERED BY:	JRS
DRAFTED BY:	JRS
REVIEWED BY:	EP
ORIGINAL RELEASE DATE:	08/14/2019
DRAWING SHEET SIZE:	D - 24x36

SHEET TITLE
RACKING DETAILS

SHEET NUMBER
SR-500 SHEET
11 of 11